

REV.	DATE	DCN #	DRAWING TREE #
A	24 JUNE 2004	E040303-00	

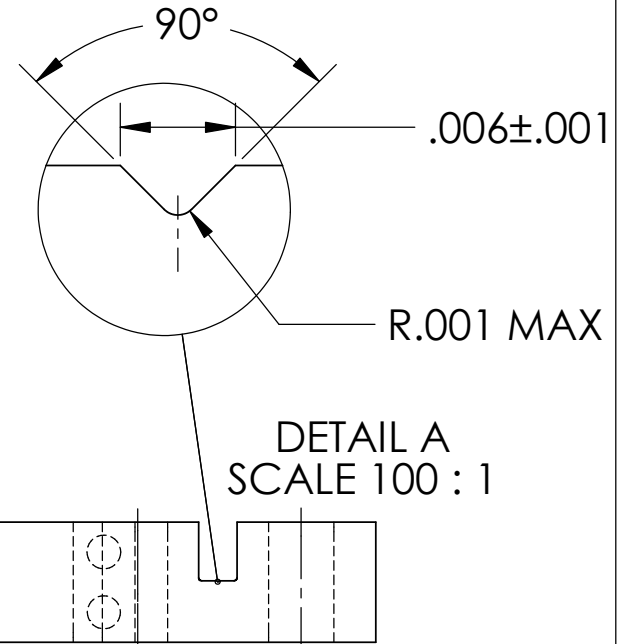

D020159_bladewirejig.step

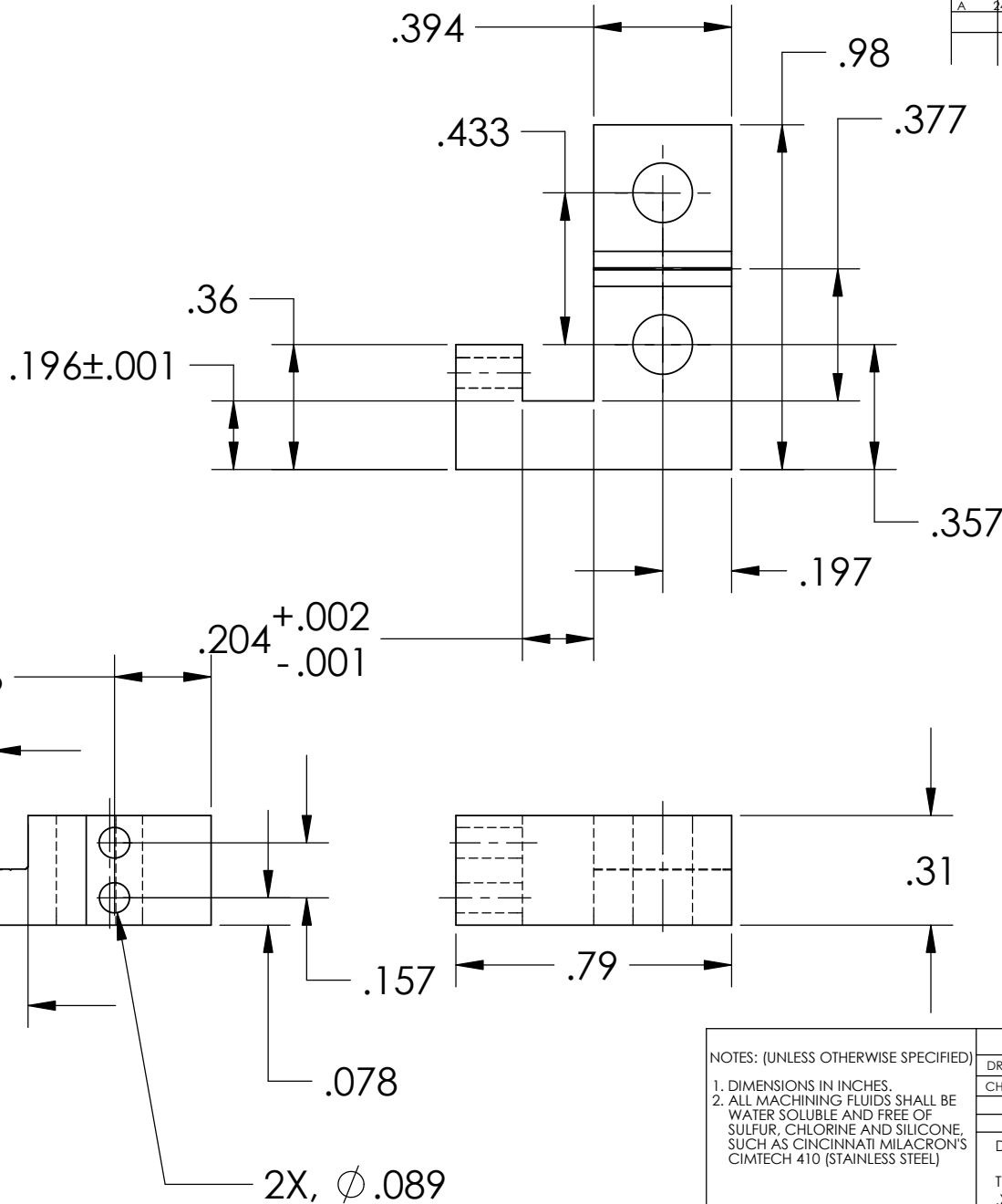

NOTES: (UNLESS OTHERWISE SPECIFIED)

1. DIMENSIONS IN INCHES.
2. ALL MACHINING FLUIDS SHALL BE WATER SOLUBLE AND FREE OF SULFUR, CHLORINE AND SILICONE, SUCH AS CINCINNATI MILACRON'S CIMTECH 410 (STAINLESS STEEL)

DRAWN	CIT	NAME	DATE	CALIFORNIA INSTITUTE OF TECHNOLOGY MASSACHUSETTS INSTITUTE OF TECHNOLOGY	
CHECKED			11/11/02		
DIMENSIONS ARE IN INCHES				SYSTEM	ADVANCED LIGO
TOLERANCES: .XX ±0.01 .XXX ±0.005 ANGULAR ±1°				SUB-SYSTEM	SUS
MATERIAL				NEXT ASSY	MC: WIRE JIG
FINISH				PART NAME	BLADE WIRE JIG GUIDE
6061-T6-AL				SIZE	DWG. NO.
				A	D020159
				SCALE: NTS	PROJECTION:
				SHEET 1 OF 1	

FILE NAME/LOCATION: