

4

3

2

1

REV.	DATE	DCN #	DRAWING TREE #
v1	10 AUG 2010	E1000301	E080191
-	-	-	-
-	-	-	-

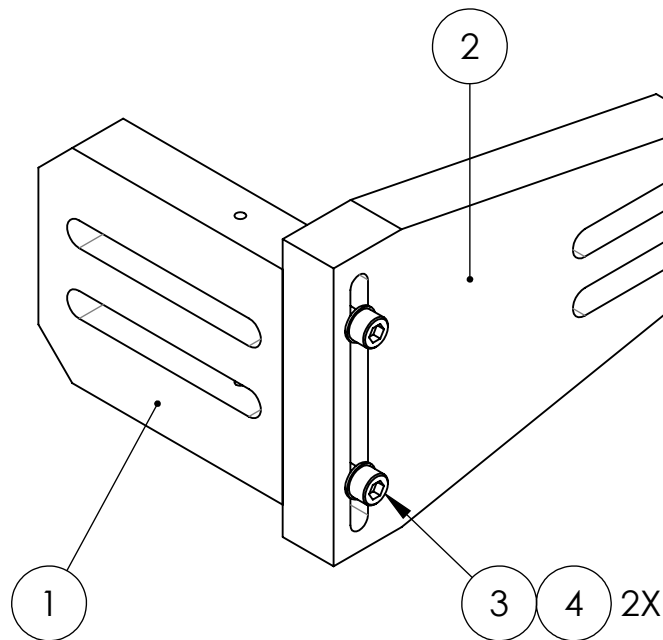

4	-	WASHER, FLAT, VENTED, #4 (U-C COMPONENTS P/N WFV-04 OR EQUIVALENT)	300 SSTL	2	1	3
3	-	SCREW, SOCKET HEAD CAP, #4-40 UNC-2A X 0.75 LONG	300 SSTL	2	1	3
2	D1002135	MOUNTING BRACKET LONGITUDINAL SECTION	6061-T6 Al	1	0	1
1	D1002134	MOUNTING BRACKET LATERAL SECTION	6061-T6 Al	1	0	1
ITEM NO.	PART NUMBER	DESCRIPTION	MATERIAL	REQ	SPARE	TOTAL

PARTS LIST

NOTES AND TOLERANCES: (UNLESS OTHERWISE SPECIFIED)

MATERIAL	N/A	FINISH	N/A μinch
----------	-----	--------	-----------

**LIGO** CALIFORNIA INSTITUTE OF TECHNOLOGY  
 MASSACHUSETTS INSTITUTE OF TECHNOLOGY

SYSTEM: **ADVANCED LIGO** SUB-SYSTEM: **SUS**

NEXT ASSY: **COIL HOLDER ASSY**

PART NAME: **MOUNTING BRACKET, COIL HOLDER**

DESIGNER	D. BRIDGES	11 AUG 2010	SIZE	DWG. NO.	REV.
DRAFTER	D. BRIDGES	14 AUG 2010	<b>A</b>	<b>D1002133</b>	<b>v1</b>
CHECKER	B. MOORE	16 AUG 2010			
APPROVAL			SCALE: 1:1	PROJECTION:	SHEET 1 OF 1

4

1

3

2

1