

PROPRIETARY AND CONFIDENTIAL  
 THIS DRAWING IS THE SOLE PROPERTY OF  
 THE GNB CORPORATION. ANY  
 REPRODUCTION IN PART OR AS A WHOLE  
 WITHOUT THE WRITTEN PERMISSION OF  
 THE GNB CORPORATION IS PROHIBITED.

REVISIONS				
ZONE	REV.	DESCRIPTION	DATE	APPROVED

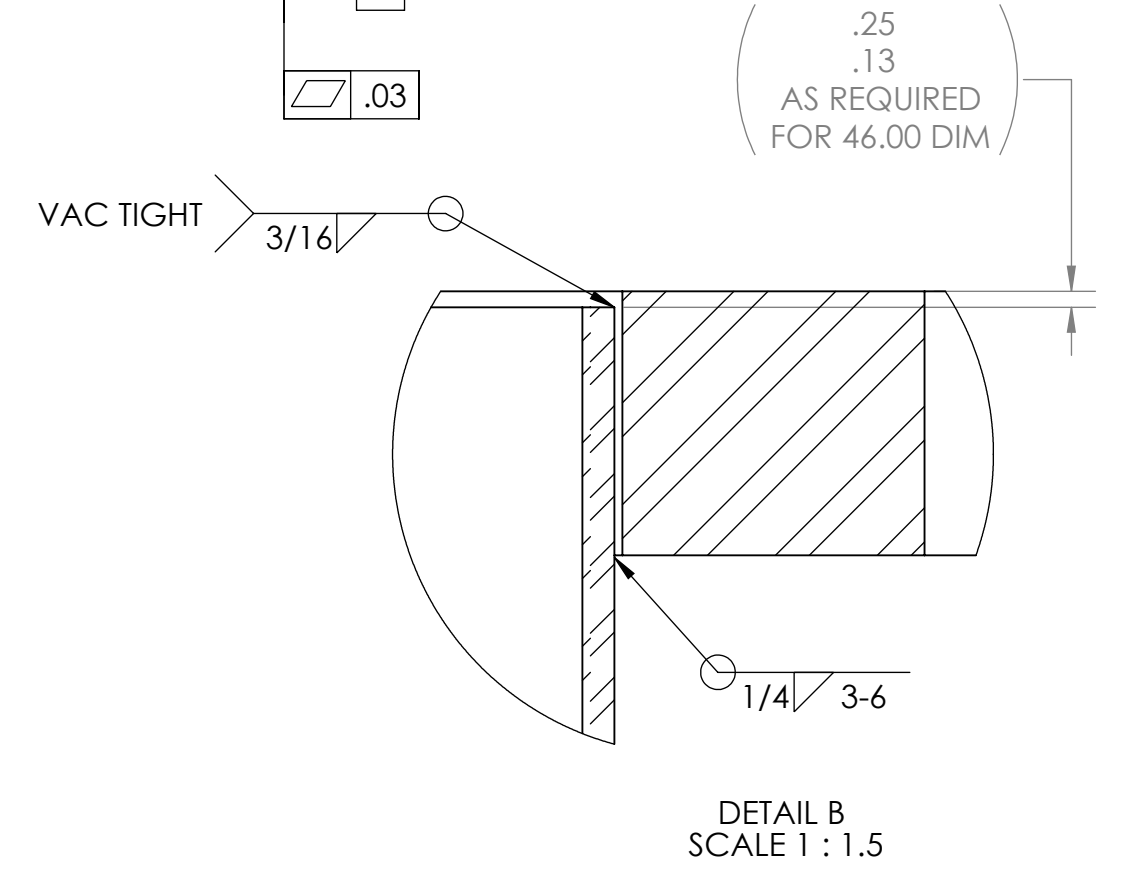
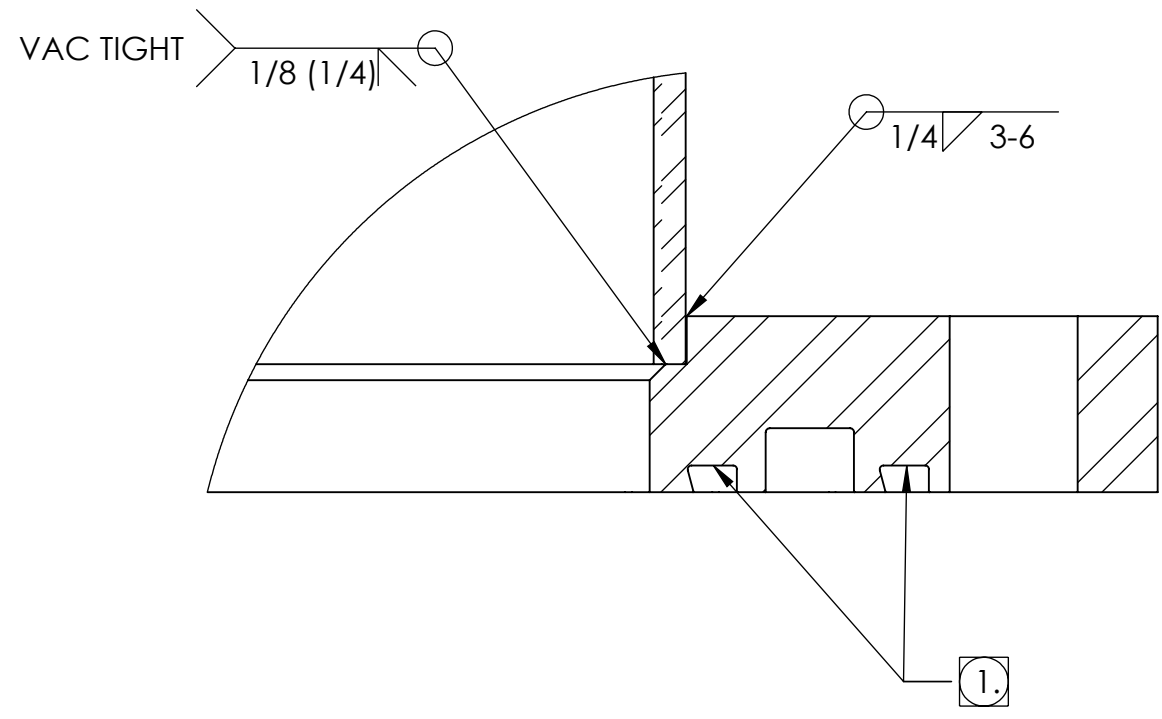
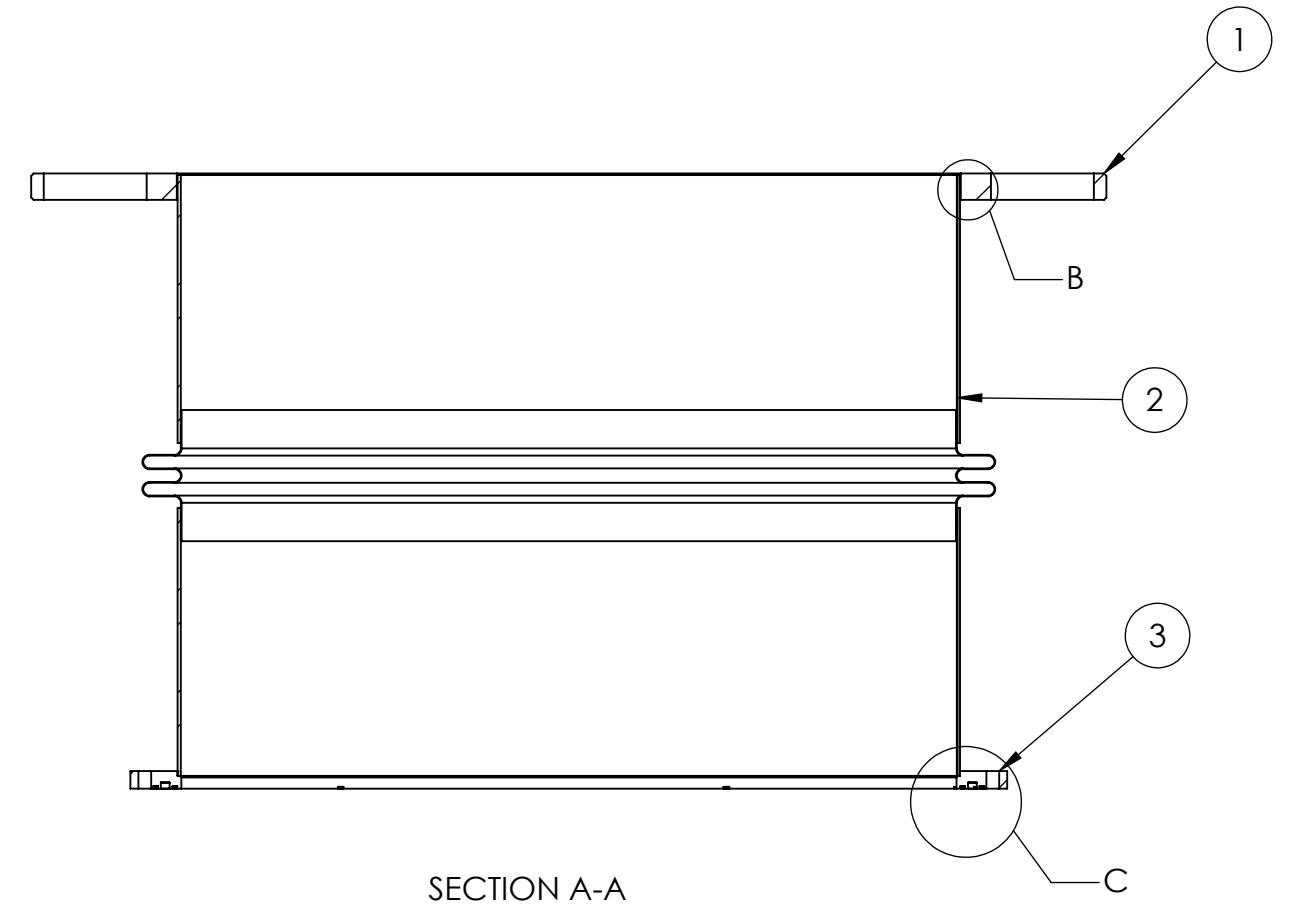
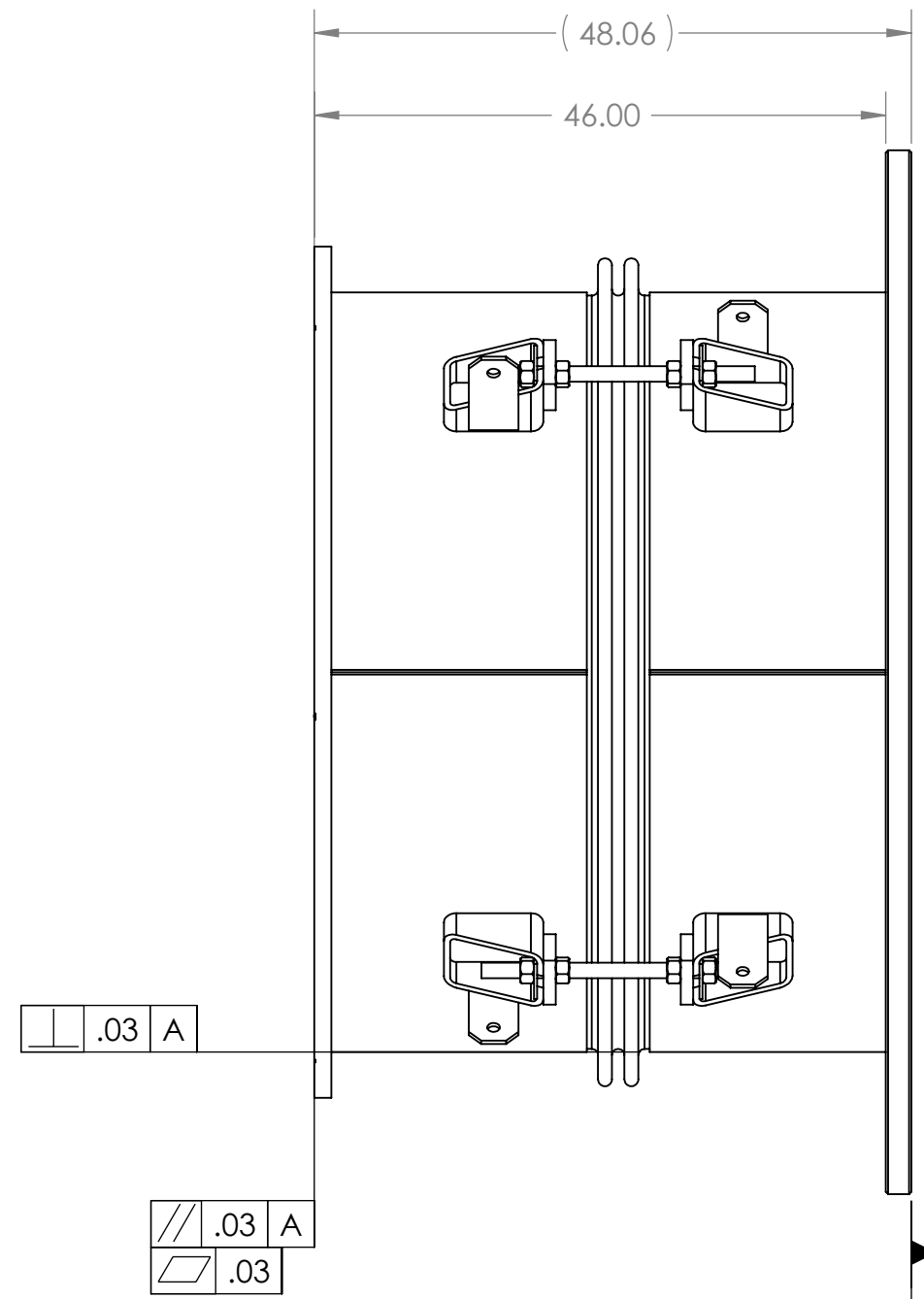
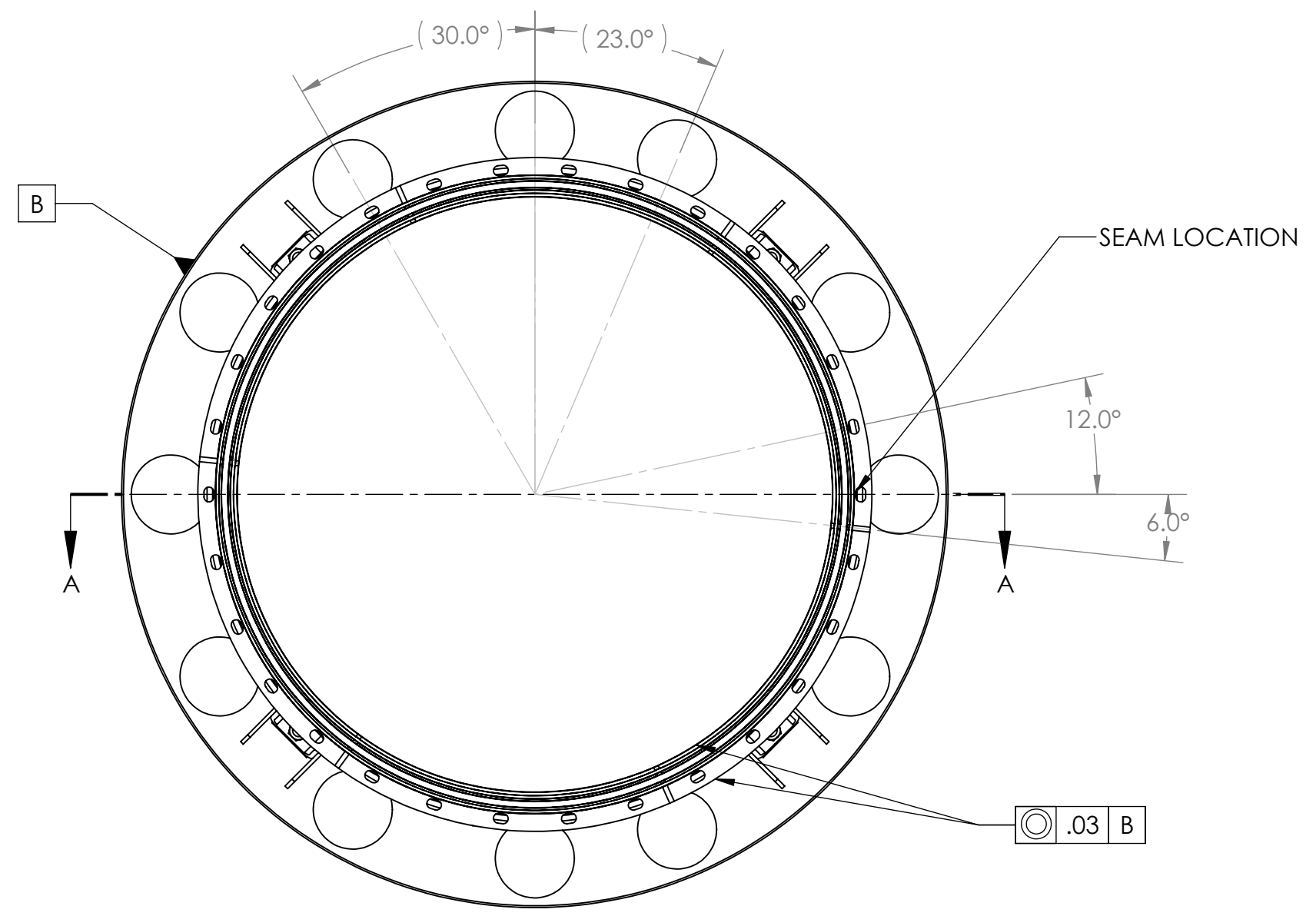

- NOTES:
- VACUUM SEALING SURFACE
  - ALL WELD PREPS TO BE DONE BY TUNGSTEN CARBIDE CUTTING TOOLS ONLY
  - WELD PER QP1750-W2, LIGO WELDING AND REPAIR PROCEDURE, LATEST REVISION
  - CLEAN WELD WIRE AND SURFACES TO BE WELDED WITH CO2 SCRUBBING
  - INTERNAL WELD SURFACE TO BE SMOOTH BUT NOT GROUND
  - ALL WELDS TO BE GTAW UNLESS OTHERWISE NOTED
  - ALL INTERNAL WELDS TO BE CONTINUOUS AND VACUUM TIGHT
  - NO POST WELD HEAT TREATMENT IS REQUIRED

DETAIL C  
 SCALE 1 : 1.5

DETAIL B  
 SCALE 1 : 1.5

ITEM NO.	PART NUMBER	DESCRIPTION	QTY.
1	114223-01S	PLATE, REDUCER, MC-B#2	1
2	114222-00WS	WELDMENT, BELLOWS SUBASSEMBLY	1
3	114230-00S	FLANGE, 60.50 ID, GROOVED	1

MATERIAL: AISI 304/ AISI 304L DUAL CERT PER SA240  
 WEIGHT: 2301.90#

UNLESS OTHERWISE SPECIFIED:  
 DIMENSIONS ARE IN INCHES  
 TOLERANCES: FINISH  
 ANGULAR: ± 0°30'  
 .XX ±.03  
 .XXX ±.005  
 UNSPECIFIED FILLETS: R.015  
 BREAK EDGES .010x45°  
 REMOVE ALL BURRS

APPROVALS: DATE  
 DRAFTER MKM2 7/7/10  
 CHECKER RW 7/22/10  
 ENGINEER MKM2 7/7/10

GNB CORPORATION  
 SCIENTIFIC AND INDUSTRIAL EQUIPMENT  
 3200 DWIGHT RD. SUITE 100  
 ELK GROVE, CA 95758  
 916-395-3003 FAX: 916-395-3363  
 www.gnbvalves.com

TITLE: WELDMENT, NIPPLE, BELLOWS, MC TUBE

THIRD ANGLE PROJECTION

DO NOT SCALE DRAWING

C DWG. NO. 114221-01WS REV  
 SCALE: 1:15 SHEET 1 OF 1