

PROPRIETARY AND CONFIDENTIAL
 THE INFORMATION CONTAINED IN THIS
 DRAWING IS THE SOLE PROPERTY OF
 GNB CORPORATION. ANY
 REPRODUCTION IN PART OR AS A WHOLE
 WITHOUT THE WRITTEN PERMISSION OF
 GNB CORPORATION IS PROHIBITED.

| REVISIONS | | | | |
|-----------|------|------------------------|-----------|----------|
| ZONE | REV. | DESCRIPTION | DATE | APPROVED |
| | A | RELEASED TO PRODUCTION | 8/23/2010 | MKM2 |

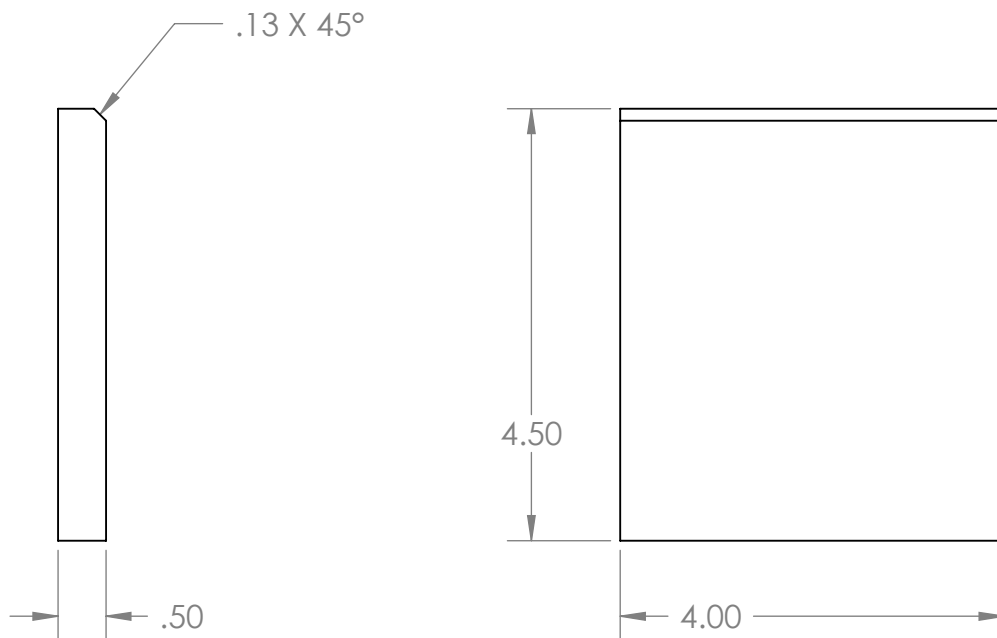

NOTES:

1. THE FOLLOWING ARE NOT ALLOWED: GRINDING, HONING, LAPPING, POLISHING, BUFFING, SANDING, BLASTING.
2. NO HYDROCARBONS ALLOWED IN THE COOLANT. COOLANT LIMITS AS FOLLOWS
 - a. WATER LEACHABLE CHLORIDES: 100PPM
 - b. TOTAL HALOGENS (INCLUDING CHLORIDES): 1000PPM
 - c. TOTAL SULFUR: 1000PPM
3. DO NOT ALLOW PART TO BE CONTAMINATED BY CARBON STEEL OR IRON CONTACT.
4. MACHINING TO BE IN LINE WITH LIGO SPECIFICATION E0900406, LATEST REVISION.
5. A 2"X12" COUPON OF MATERIAL CUT FROM THE SAME LOT OF MATERIAL SHALL BE PROVIDED WITH EACH PIECE.

| DESCRIPTION: PLT, .50 THK, 4.00 WD, 4.50 LG | | <p>SCIENTIFIC AND INDUSTRIAL EQUIPMENT</p> <p>3200 DWIGHT RD, SUITE 100 ELK GROVE, CA 95758 916-395-3003 FAX: 916-395-3363 WWW.GNBVALVES.COM</p> | | | | | | | | | | | | | | | |
|---------------------------------------------------|---------------------------------------------------------------------------------------------------------------------------------------------------------------------------------------------------------------------------------------------------------------------------------------------------------------------------------------|-----------------------------------------------------------------------------------------------------------------------------------------------------------------------------------|-----------|------|--|--|------|------|---------|------|--------|---------|----|--------|----------|------|--------|
| MATERIAL: AISI 304/AISI 304L DUAL CERT PER SA-240 | | | | | | | | | | | | | | | | | |
| UNLESS OTHERWISE SPECIFIED: | WEIGHT: 2.59 # | <p>DWG. NO. A 114271-00S</p> <p>SCALE: 1:2 SHEET 1 OF 1</p> | | | | | | | | | | | | | | | |
| DIMENSIONS ARE IN INCHES | <table border="1"> <thead> <tr> <th colspan="3">APPROVALS</th> </tr> <tr> <th></th> <th>NAME</th> <th>DATE</th> </tr> </thead> <tbody> <tr> <td>DRAFTER</td> <td>MKM2</td> <td>7/2/10</td> </tr> <tr> <td>CHECKER</td> <td>RW</td> <td>7/9/10</td> </tr> <tr> <td>ENGINEER</td> <td>MKM2</td> <td>7/2/10</td> </tr> </tbody> </table> | | APPROVALS | | | | NAME | DATE | DRAFTER | MKM2 | 7/2/10 | CHECKER | RW | 7/9/10 | ENGINEER | MKM2 | 7/2/10 |
| APPROVALS | | | | | | | | | | | | | | | | | |
| | | | NAME | DATE | | | | | | | | | | | | | |
| DRAFTER | | MKM2 | 7/2/10 | | | | | | | | | | | | | | |
| CHECKER | RW | 7/9/10 | | | | | | | | | | | | | | | |
| ENGINEER | MKM2 | 7/2/10 | | | | | | | | | | | | | | | |
| TOLERANCES: | | | | | | | | | | | | | | | | | |
| ANGULAR: ± 0°30' | FINISH 125 | | | | | | | | | | | | | | | | |
| .XX ± .03 | | | | | | | | | | | | | | | | | |
| .XXX ± .005 | | | | | | | | | | | | | | | | | |
| UNSPECIFIED FILLETS: R.015 | | | | | | | | | | | | | | | | | |
| BREAK EDGES .010 x 45° | | | | | | | | | | | | | | | | | |
| REMOVE ALL BURRS | | | | | | | | | | | | | | | | | |
| // . □ . ⊥ WITHIN .03 | | | | | | | | | | | | | | | | | |
| THIRD ANGLE PROJECTION | | | | | | | | | | | | | | | | | |
| DO NOT SCALE DRAWING | | REV A | | | | | | | | | | | | | | | |