

PROPRIETARY AND CONFIDENTIAL
 THE INFORMATION CONTAINED IN THIS
 DRAWING IS THE SOLE PROPERTY OF
 GNB CORPORATION. ANY
 REPRODUCTION IN PART OR AS A WHOLE
 WITHOUT THE WRITTEN PERMISSION OF
 GNB CORPORATION IS PROHIBITED.

REVISIONS				
ZONE	REV.	DESCRIPTION	DATE	APPROVED
	A	RELEASED TO PRODUCTION	8/25/2010	MKM2

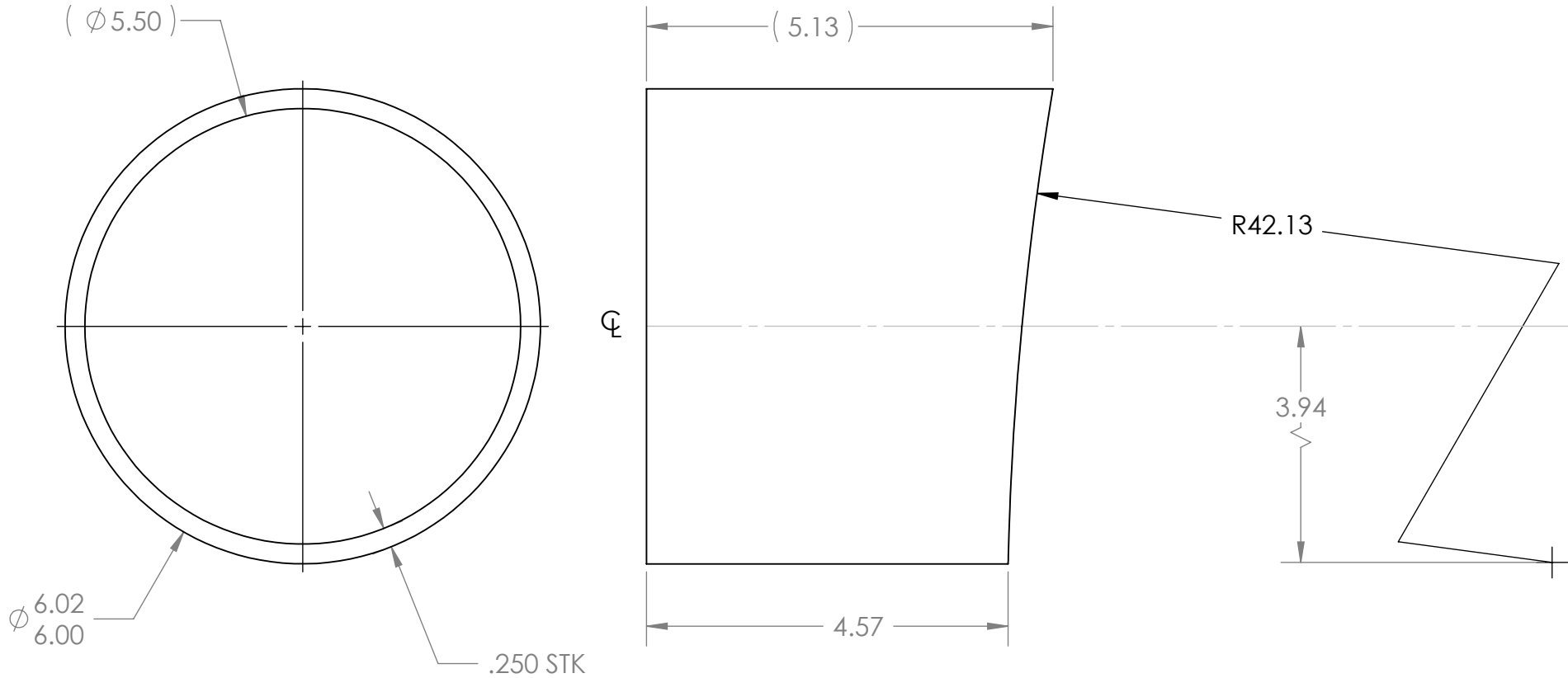

NOTES:

1. THE FOLLOWING ARE NOT ALLOWED: GRINDING, HONING, LAPPING, POLISHING, BUFFING, SANDING, BLASTING.
2. NO HYDROCARBONS ALLOWED IN THE COOLANT. COOLANT LIMITS AS FOLLOWS
 - a. WATER LEACHABLE CHLORIDES: 100PPM
 - b. TOTAL HALOGENS (INCLUDING CHLORIDES): 1000PPM
 - c. TOTAL SULFUR: 1000PPM
3. DO NOT ALLOW PART TO BE CONTAMINATED BY CARBON STEEL OR IRON CONTACT.
4. MACHINING TO BE IN LINE WITH LIGO SPECIFICATION E0900406, LATEST REVISION.

DESCRIPTION: TUBE, 6.00 OD, .25 WALL, 5.13 LG		<p>SCIENTIFIC AND INDUSTRIAL EQUIPMENT</p> <p>3200 DWIGHT RD, SUITE 100 ELK GROVE, CA 95758 916-395-3003 FAX: 916-395-3363 WWW.GNBVALVES.COM</p>															
MATERIAL: AISI 304/AISI 304L DUAL CERT PER SA240																	
UNLESS OTHERWISE SPECIFIED:	WEIGHT: 6.25 #	<table border="1"> <thead> <tr> <th colspan="3">APPROVALS</th> </tr> <tr> <th></th> <th>NAME</th> <th>DATE</th> </tr> </thead> <tbody> <tr> <td>DRAFTER</td> <td>MKM2</td> <td>7/22/10</td> </tr> <tr> <td>CHECKER</td> <td>RW</td> <td>7/22/10</td> </tr> <tr> <td>ENGINEER</td> <td>MKM2</td> <td>7/22/10</td> </tr> </tbody> </table>	APPROVALS				NAME	DATE	DRAFTER	MKM2	7/22/10	CHECKER	RW	7/22/10	ENGINEER	MKM2	7/22/10
APPROVALS																	
	NAME		DATE														
DRAFTER	MKM2		7/22/10														
CHECKER	RW	7/22/10															
ENGINEER	MKM2	7/22/10															
DIMENSIONS ARE IN INCHES	FINISH 125																
TOLERANCES:	ANGULAR: ± 0°30'																
.XX ± .03	.XXX ± .005																
UNSPECIFIED FILLETS: R.015	BREAK EDGES .010 x 45°																
REMOVE ALL BURRS	// ◻ ⊥ WITHIN .03																
THIRD ANGLE PROJECTION																	
DO NOT SCALE DRAWING		TITLE: TUBE, 8" CF PORT, MCB TUBE DWG. NO. 114432-00S SCALE: 1:2															
		SHEET 1 OF 1 REV A															