

PROPRIETARY AND CONFIDENTIAL
 DRAWING IS THE SOLE PROPERTY OF
 THE GNB CORPORATION. ANY
 REPRODUCTION IN PART OR AS A WHOLE
 WITHOUT THE WRITTEN PERMISSION OF
 THE GNB CORPORATION IS PROHIBITED.

REVISIONS				
ZONE	REV.	DESCRIPTION	DATE	APPROVED
	A	REVISED WELD CALL-OUT	8/11/2010	MKM2
	B	RELEASED TO PRODUCTION	8/25/2010	MKM2

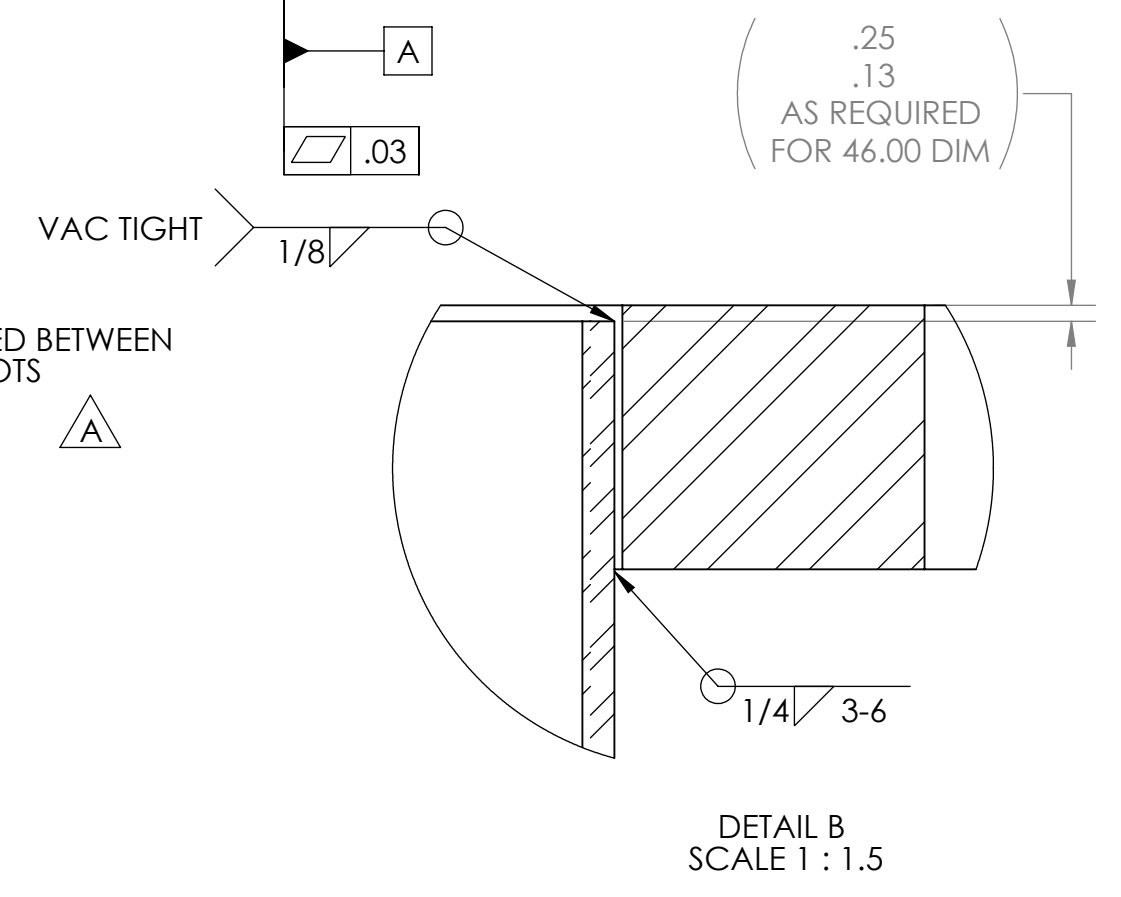
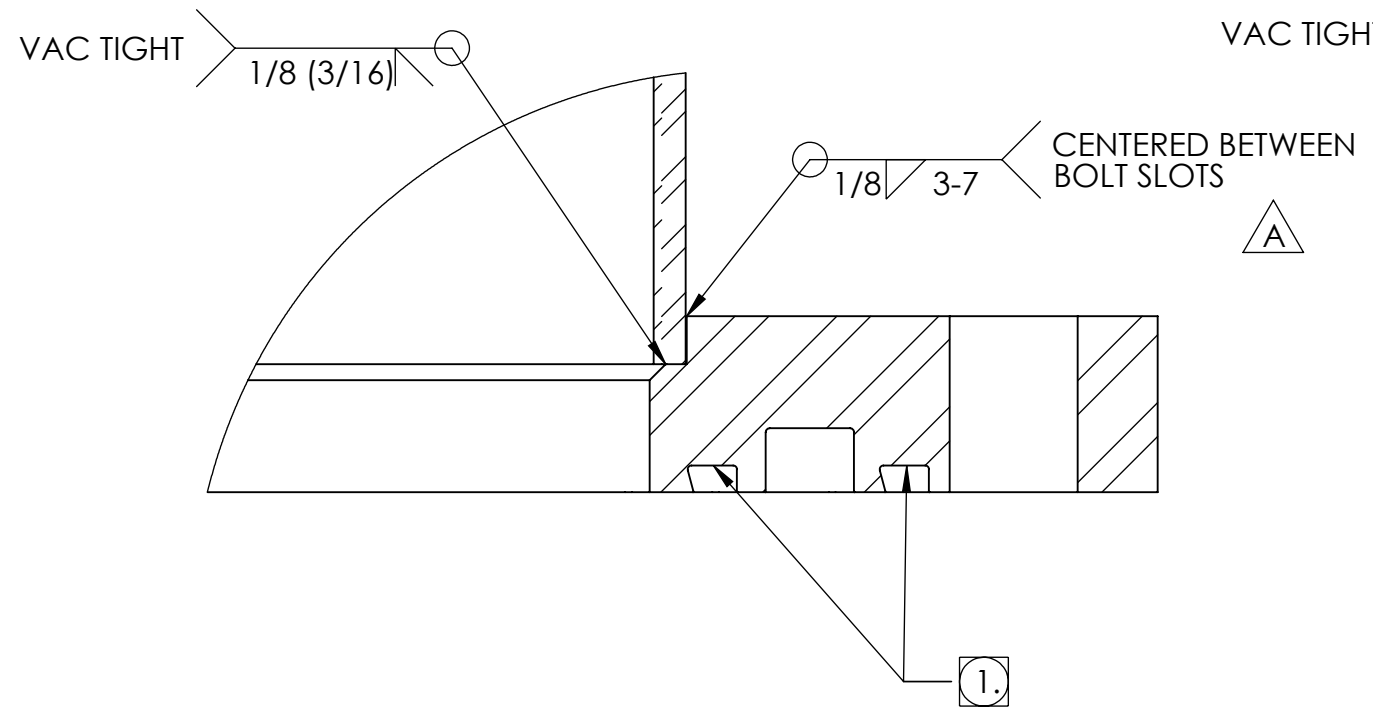
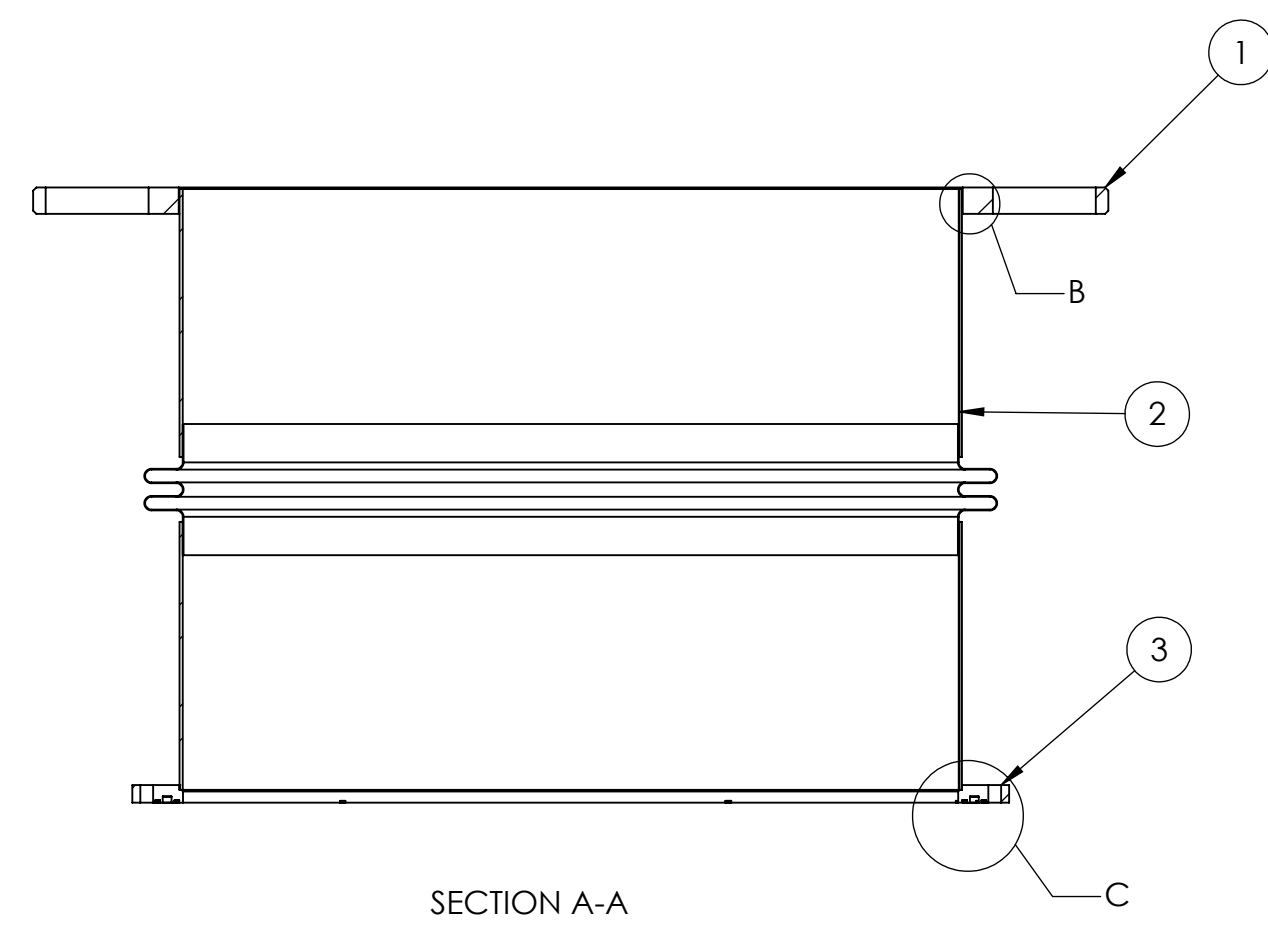
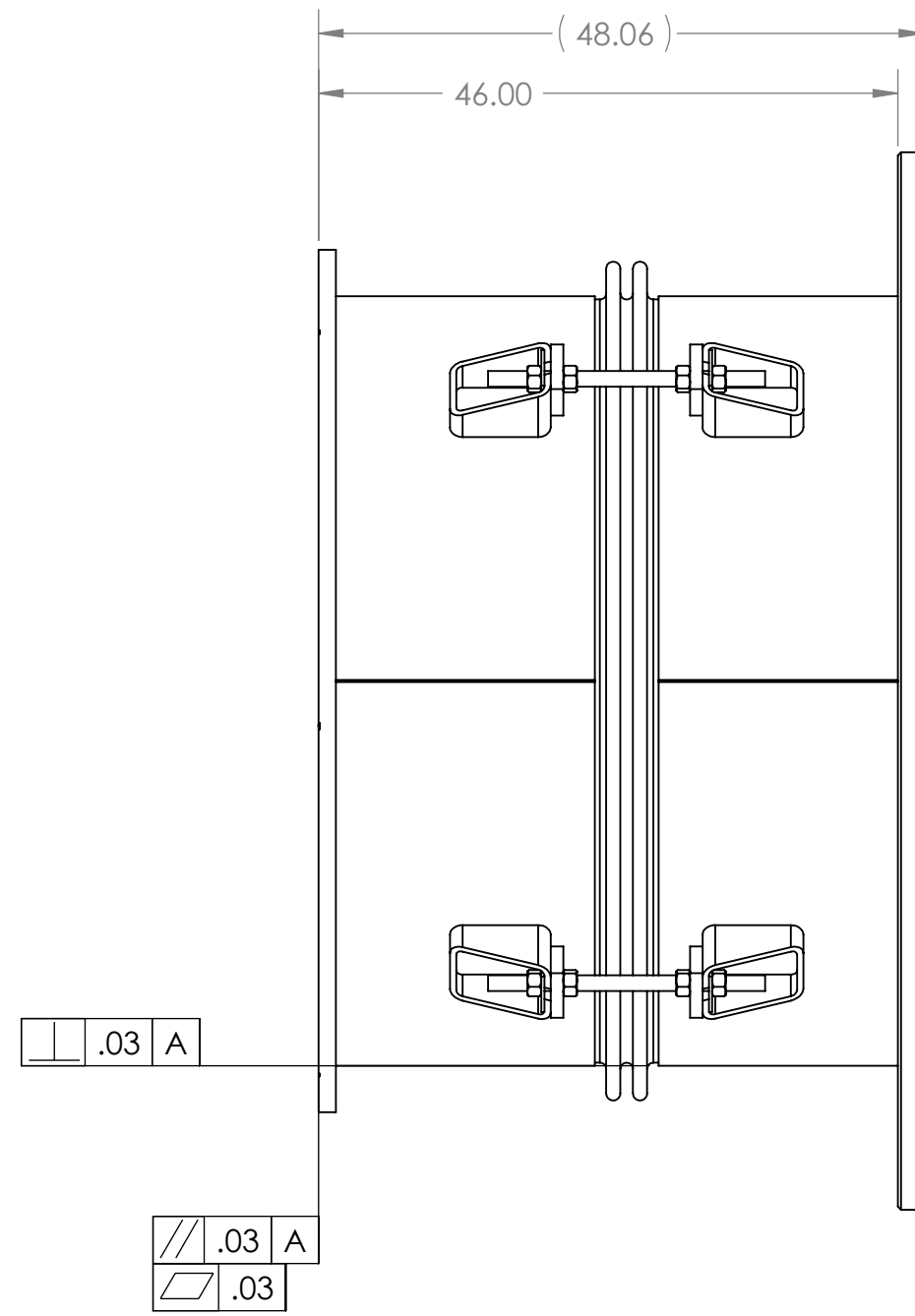
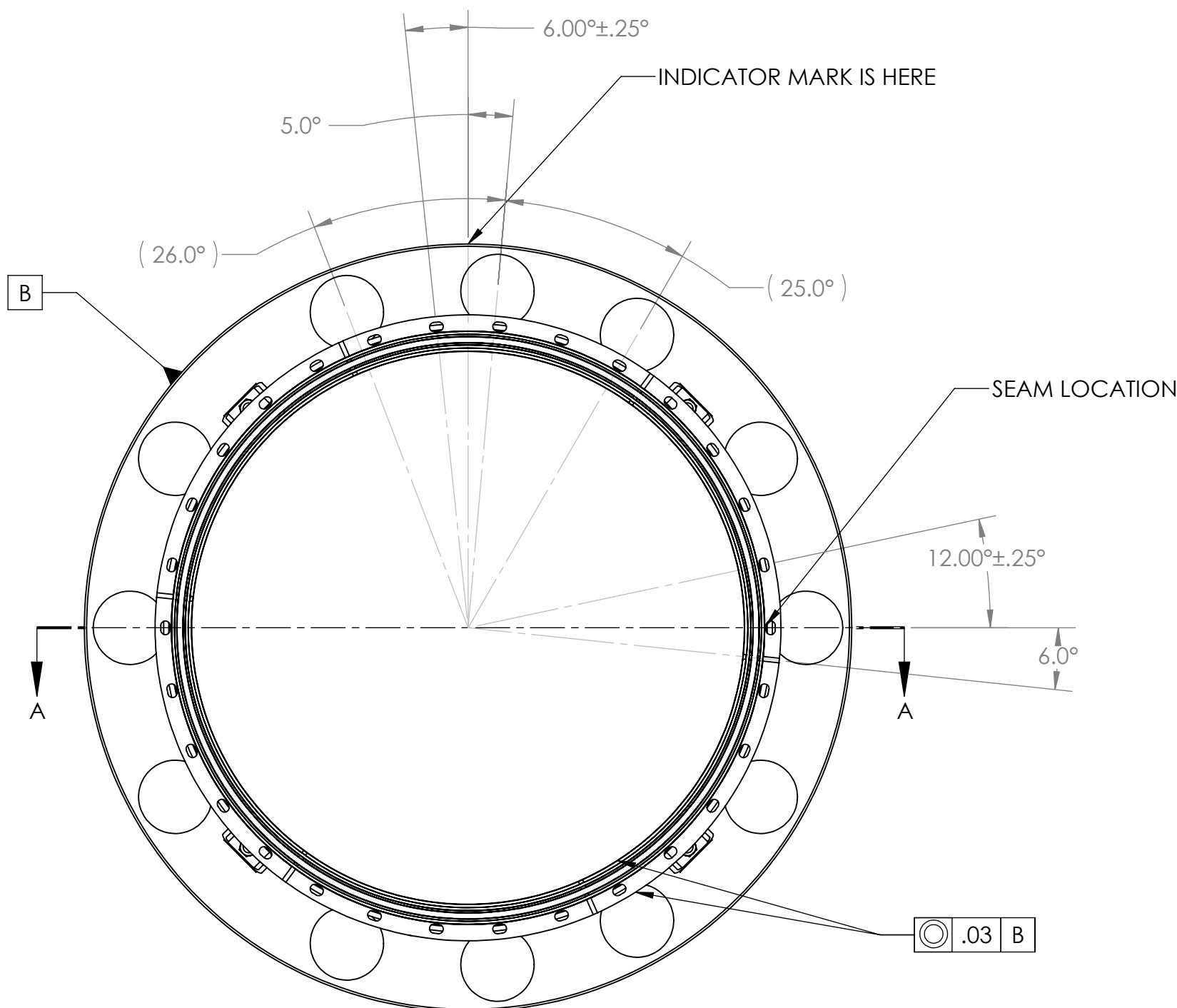

- NOTES:
- VACUUM SEALING SURFACE
 - ALL WELD PREPS TO BE DONE BY TUNGSTEN CARBIDE CUTTING TOOLS ONLY
 - WELD PER QP1750-W2, LIGO WELDING AND REPAIR PROCEDURE, LATEST REVISION
 - CLEAN WELD WIRE AND WELDED SURFACES WITH CO2 SCRUBBING
 - INTERNAL WELD SURFACE TO BE SMOOTH BUT NOT GROUND
 - ALL WELDS TO BE GTAW UNLESS OTHERWISE NOTED
 - ALL INTERNAL WELDS TO BE CONTINUOUS AND VACUUM TIGHT
 - NO POST WELD HEAT TREATMENT IS REQUIRED

ITEM NO.	PART NUMBER	DESCRIPTION	QTY.
1	114223-00S	PLATE, REDUCER, WMCB#1	1
2	114222-00WS	WELDMENT, BELLOWS SUBASSEMBLY	1
3	114230-00S	FLANGE, 60.50 ID, GROOVED	1

MATERIAL: AISI 304/ AISI 304L DUAL CERT PER SA240
 WEIGHT: 2273.87#

UNLESS OTHERWISE SPECIFIED:
 DIMENSIONS ARE IN INCHES
 TOLERANCES: FINISH
 ANGULAR: ± 0°30'
 .XX ±.03
 .XXX ±.005
 UNSPECIFIED FILLETS: R.015
 BREAK EDGES .010x45°
 REMOVE ALL BURRS

APPROVALS: DATE
 DRAFTER MKM2 7/7/10
 CHECKER RW 7/22/10
 ENGINEER MKM2 7/7/10

GNB CORPORATION
 SCIENTIFIC AND INDUSTRIAL EQUIPMENT
 3200 DWIGHT RD. SUITE 100
 ELK GROVE, CA 95758
 916-395-3003 FAX: 916-395-3363
 www.gnbvalves.com

TITLE: WELDMENT, NIPPLE, BELLOWS, MC TUBE

DO NOT SCALE DRAWING

SCALE: 1:15 SHEET 1 OF 1

REV B