

REV.	DATE	DCN #	DRAWING TREE #
A	28 MAR 2008	E080113-00	

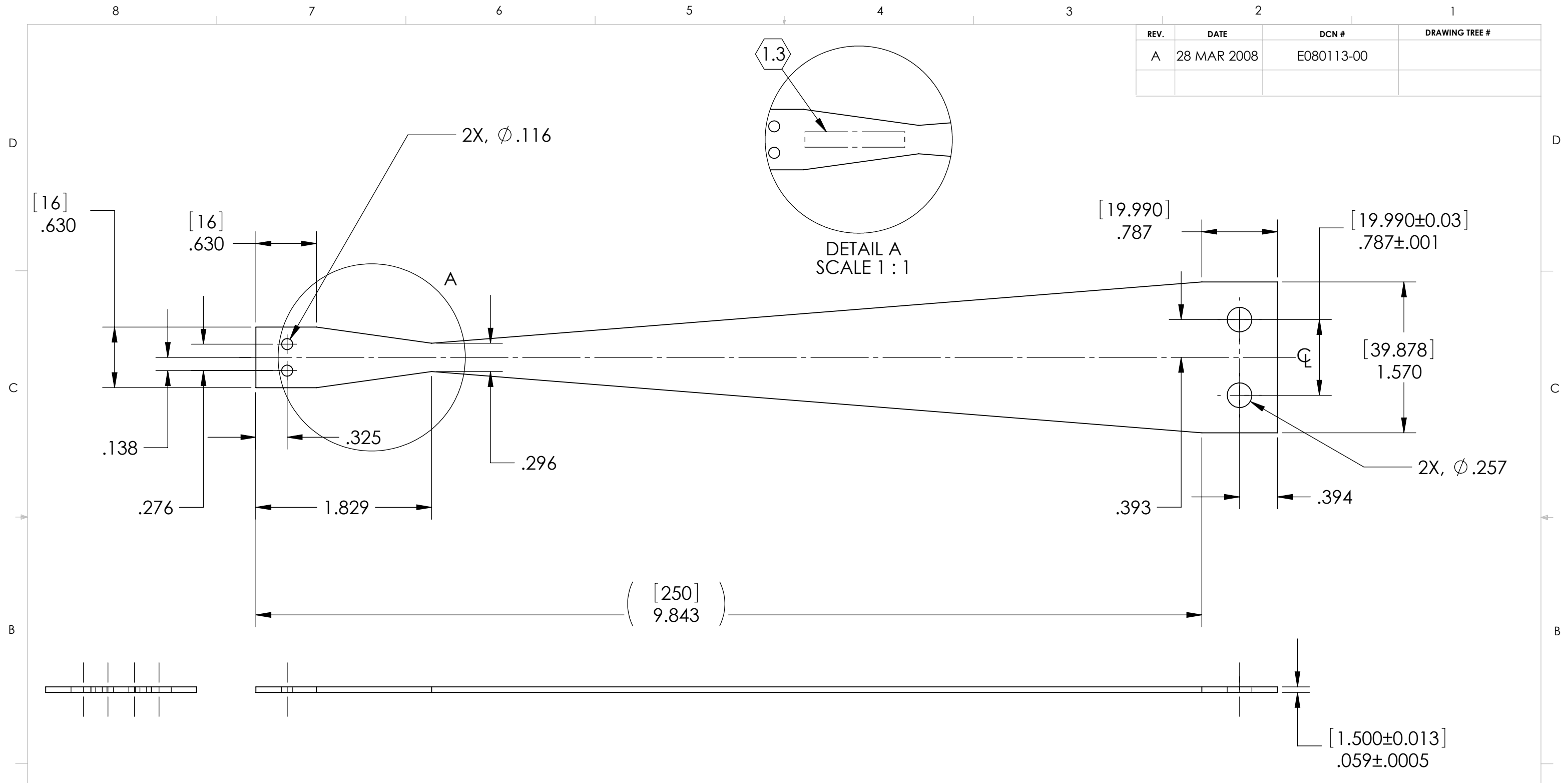

**MANUFACTURING NOTES: (UNLESS OTHERWISE SPECIFIED)**

1.1 REMOVE ALL SHARP EDGES, R.02 MIN.

1.2 ALL MACHINING FLUIDS SHALL BE WATER SOLUBLE AND FREE OF SULFUR, CHLORINE AND SILICONE, SUCH AS CINCINNATI MILACRON'S CIMTECH 410 (SSTL).

1.3 ENGRAVE OR STAMP DRAWING PART NUMBER ON NOTED SURFACE OF PART AND A THREE DIGIT SERIAL NUMBER, SERIAL NUMBERS START AT 001 FOR THE FIRST PART AND PROCEED CONSECUTIVELY, USE .07" HIGH CHARACTERS. EXAMPLE: D020188-001. A VIBRATORY TOOL MAY BE USED.

1.4 SHEET 1 OF 2 SHOWS VIEWS PRIOR TO FORMING.

1.5 AFTER FORMING THE BLADES ARE ANNEALED AT 490°C FOR 4 HOURS AND AIR COOLED BACK TO ROOM TEMPERATURE.

1.6 SHEET 2 OF 2 VIEWS ARE SHOWN AFTER FORMING & ANNEALING.

1.7 AS SHOWN IN SHEET 2 OF 2, THE RADIUS OF CURVATURE IS THE INTERNAL RADIUS.

1.8 AS SHOWN, THE OVERALL DEFLECTION IS MEASURED FROM THE BOTTOM OF THE BASE POINT TO THE HIGHEST POINT ON THE TIP OF THE BLADE.

**OTHER NOTES (FOR INTERNAL USE)**

2.1 SHAPE FACTOR FOR LOWER BLADE = 1.32

2.2 LOAD ON LOWER BLADE (FLAT) = 4.829 kg

2.3 PREDICTED UNCOUPLED FREQUENCY = 2.36 Hz

2.4 PREDICTED FIRST INTERNAL MODE = 90 Hz.

2.5 MAXIMUM STRESS = 789 MPa

2.6 SOLIDWORKS RADIUS VALUE OVER WRITTEN, WITH VALUE CALCULATED BY MVP.

2.7 IN SW PART, BLADE MUST BE DRAWN WITH SHEET METAL AND EXTRUDED VERTICALLY DOWNWARDS.

2.8 IN SW PART RADIUS SHOULD BE ADJUSTED TO ATTAIN DESIRED LENGTH ON DRAWING SHEET.

DIMENSIONS ARE IN INCHES

TOLERANCES:  
 .XX ± .01  
 .XXX ± .005

ANGULAR ± 0.5°

<b>MATERIAL</b>		
MARAGING STEEL C250		
<b>FINISH</b>		
	<b>NAME</b>	<b>DATE</b>
<b>DRAWN</b>	C TORRIE	JAN 2008
<b>CHECKED</b>	B KIRSNER	JAN 2008
<b>APPROVED</b>		

<b>LIGO</b> CALIFORNIA INSTITUTE OF TECHNOLOGY MASSACHUSETTS INSTITUTE OF TECHNOLOGY IGR, GLASGOW UNIVERSITY GEO 600 GROUP	
<b>SYSTEM</b>	ADVANCED LIGO
<b>SUB-SYSTEM</b>	SUS
<b>NEXT ASSY</b>	OMC UPPER BLADES
<b>PART NAME</b>	
UPPER BLADE (LHO)	
<b>SIZE</b>	<b>DWG. NO.</b>
B	D080018
<b>SCALE:</b> NTS	<b>PROJECTION:</b>
SHEET 1 OF 2	

FILE NAME/LOCATION: 1

8 7 6 5 4 3 2 1

REV.	DATE	DCN #	DRAWING TREE #

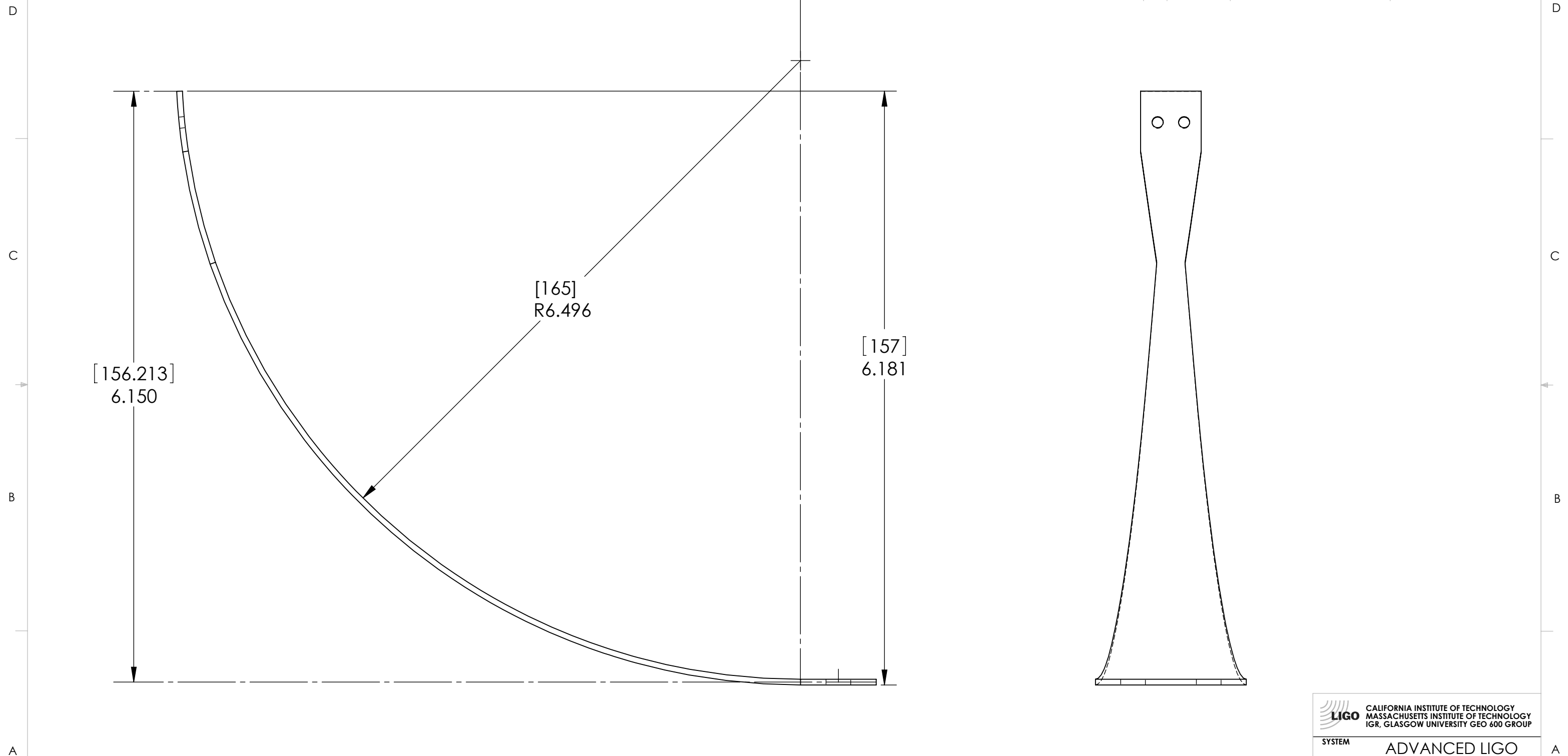

**LIGO** CALIFORNIA INSTITUTE OF TECHNOLOGY  
 MASSACHUSETTS INSTITUTE OF TECHNOLOGY  
 IGR, GLASGOW UNIVERSITY GEO 600 GROUP

SYSTEM	ADVANCED LIGO	
SUB-SYSTEM	SUS	
NEXT ASSY	OMC: UPPER BLADE	
PART NAME	UPPER BLADE (LHO)	
SIZE	DWG. NO.	REV.
B	D080018	A
SCALE: NTS	PROJECTION:	SHEET 2 OF 2

8 7 6 5 4 3 2 1

FILE NAME/LOCATION: 1