

NOTES: (UNLESS OTHERWISE SPECIFIED)
 x

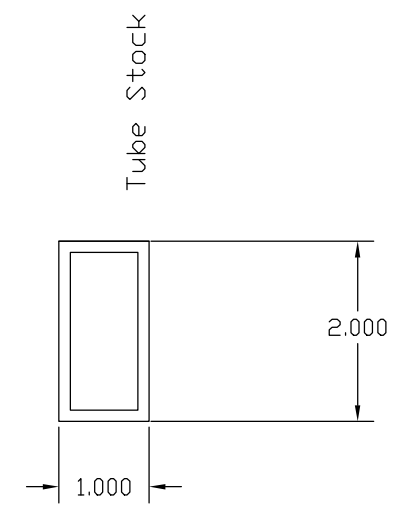
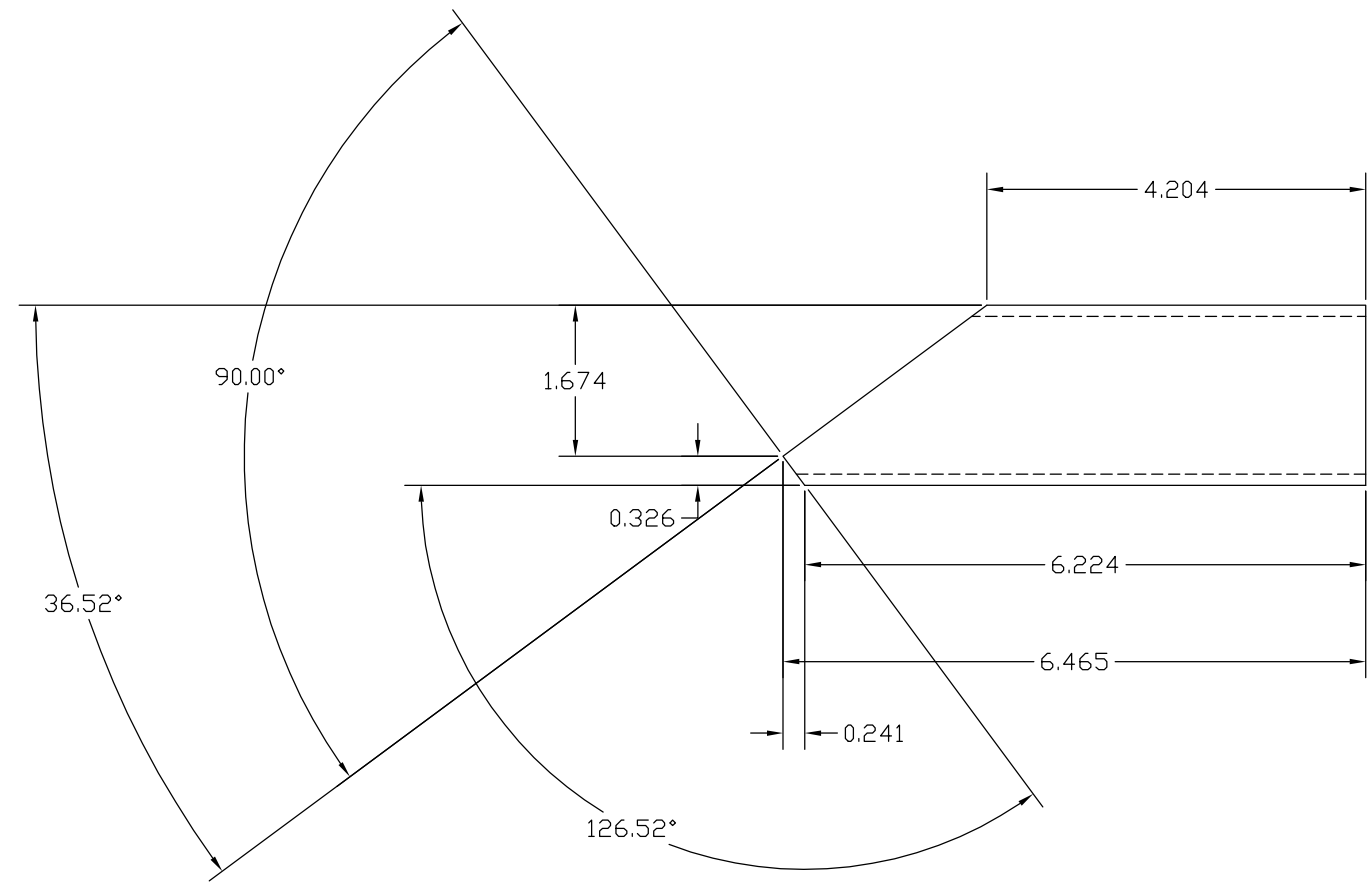

MAKE TWO PER ASSEMBLY

REF	QTY	PART or DRWG No.	DESCRIPTION	MATERIAL
5	-	-	-	-
4	-	-	-	-
3	-	-	-	-
2	-	-	-	-
1	-	-	-	-

DWG. NO.		DESCRIPTION		USED ON: XXX	NEXT ASS'Y: XXX	REV	DESCRIPTION	DCN NUMBER	APPR'D	CHECK	DRWN	DATE	CAD FILE	SCALE	SIZE	DWG. NO.	SHEET
XXX	XXX					A	RELEASE	E010214-00-D				10-31-01	D010211-A	FULL	D	D010211-A	1
<p>TOLERANCES: FRACTIONAL ± 1/32 TWO PLACE DECIMAL ± .01 THREE PLACE DECIMAL ± .005 ANGULAR ± 1 deg.</p> <p>UNLESS OTHERWISE SPECIFIED DIMENSIONS ARE IN INCHES</p> <p>ANGULARMACH ± BEND ± FINISHED SURFACE RMS 63 BREAK CORNERS and EDGES REMOVE ALL BURRS</p>													<p>LIGO CALIFORNIA INSTITUTE OF TECHNOLOGY MASSACHUSETTS INSTITUTE OF TECHNOLOGY</p>				
<p>MATERIAL: Alum: 6061 T6 TUBE 1 X 2 X .12</p> <p>HEAT TREAT: TBD</p> <p>FINISH: None</p>													<p>TITLE BRACE #3</p>				
<p>REFERENCE DRAWINGS</p>													<p>SCALE FULL</p>				