

- NOTES CONTINUED:
5. SCRIBE, ENGRAVE, OR MECHANICALLY STAMP (NO INKS OR DYES) DRAWING PART NUMBER AND REVISION ON NOTED SURFACE FOLLOWED ON THE NEXT LINE BY A THREE DIGIT SERIAL NUMBER. SERIAL NUMBERS START AT 001 FOR THE FIRST ARTICLE AND PROCEED CONSECUTIVELY. USE .07" HIGH CHARACTERS. EXAMPLE: A
 DXXXXX-VY, S/N 001
 VIBRATORY TOOL MAY BE USED.
6. APPROXIMATE WEIGHT = X.XXX LB.
7. MACHINE ALL SURFACES TO REMOVE OXIDES AND MILL FINISH. USE OF ABRASIVE REMOVAL TECHNIQUES IS NOT ALLOWED. REFER TO LIGO-E0900364
8. ALL PARTS SHALL BE MANUFACTURED IN ACCORDANCE WITH LIGO SPECIFICATION E0900364.
9. ALL HELI-COIL HOLES TO BE PREPARED ACCORDING TO EMHART HELI-COIL PRODUCT CATALOG, HC2006, REV 4
10. ALL HELI-COIL INSERTS TO BE INSTALLED BY LIGO PERSONNEL AFTER DELIVERY OF FINISHED PARTS. USE NITRONIC 60 THREADED INSERTS
11. ALL MATERIAL IS TO BE VIRGIN MATERIAL (i.e. NO WELD REPAIRS, PLUGS OR RECYCLED MATERIAL). NO REPAIRS SHALL BE MADE UNLESS APPROVED IN ADVANCE, AND IN WRITING, BY LIGO LABORATORY. REFER TO LIGO-E0900364.
12. SURFACE FINISH TO BE AS-PROCESSED FROM MILL/SUPPLIER, FREE FROM SCRATCHES OR GOUGES.
13. PART WILL BE PORCELAIN COATED PER LIGO SPECIFICATION E1000083 AFTER FABRICATION. THE INDICATED HOLES WILL BE MASKED PRIOR TO PORCELAIN COATING TO APPROXIMATELY 2.5X HOLE DIAMETER GENERATED ON BOTH SIDES OF THE HOLE.
14. DIMENSIONS APPLY BEFORE PORCELAIN COATING UNLESS SPECIFIED
15. BEND RADIUS: UNLESS OTHERWISE NOTED, THE BEND RADIUS SHOULD BE THE MINIMUM REQUIRED TO FORM WITHOUT CRACKING OR REQUIRING ADDITIONAL WORK WHEN FORMING. IN PARTICULAR IF SHEET METAL IS TO BE PORCELAIN COATED, THE BEND RADIUS SHALL BE A MINIMUM OF .12" OUTSIDE RADIUS OF BEND UNLESS OTHERWISE NOTED.

REV.	DATE	DCN #	DRAWING TREE #

CONNECTOR J1

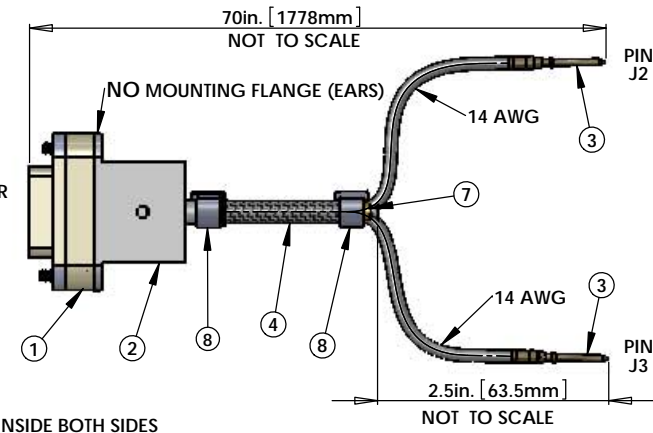
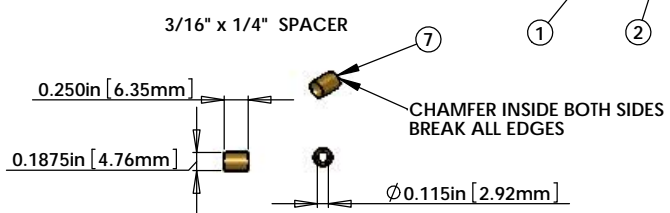
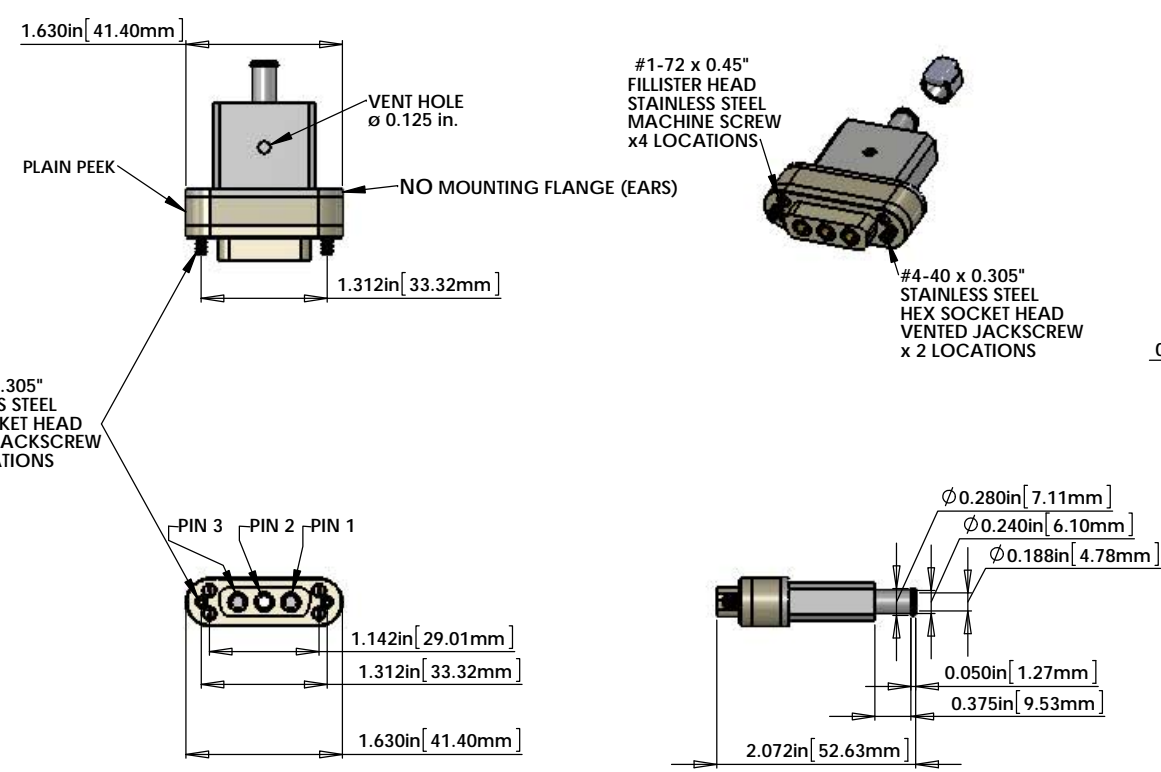

PIN J2, J3

NOT TO SCALE

CRIMP PIN NEWARK P/N 94B8812
 CRIMP PIN HARTING # TB09150006126
 HARTING CRIMPER # 79K0525
 STRIPPING LENGTH FOR WIRE 0.236" (6mm)

NOTES 9, 10, 13 and 14 DO NOT APPLY TO THIS PART

BILL OF MATERIALS				
ITEM NO.	PART NUMBER	DESCRIPTION	QTY.	LENGTH
1	CUSTOM DB3 FEMALE TICOR #	DB3 FEMALE CONNECTOR (J1) FOR UHV (PEEK)	1	
2	TS0148-15CG03BST-188	DB3 CONNECTOR BACK SHELL (NO EARS) FOR UHV (STAINLESS)	1	
3	94B8812	CRIMP PINS (J2, J3) HARTING # 09 15 000 6126 NEWARK # 94B8812	2	
4	C1	2 COND. (2 WIRES + SHIELD) CABLE WITH 5 COPPER BRAID (SHIELD) AND 6 PEEK OVERBRAID	1	70in.
5	CONTINENTAL PART #24x3x40BC	COPPER BRAID - CONTINENTAL CORDAGE PART #24x3x40BC	1	70in.
6	#6759	PEEK BRAID - PART #6759 MANUFACTURED WITH ZEUS 0.016" BLACK PEEK DRAWN MONOFILAMENT	1	70in.
7	SPACER	3/16" SPACER 1/4" LENGTH 0.115" i.d.	1	
8	GLENAIR # 600-052 or BAND-IT # A10086	GLENAIR # 600-052 STANDARD BRAID CLAMP or BAND-IT PART # A10086 (0.240" WIDE) ("BAG OF 100" # A10089)	2	

* NOTE: THE OVERALL LENGTH IS MEASURED FROM PIN TIP (3 PIN) TO PIN TIP (CRIMP PINS) OF THE CABLE. THE OTHER MEASUREMENT IS SPACER TO PIN TIPS (CRIMP PINS). USE WHATEVER LENGTH IS NECESSARY FOR THE INTERNAL WIRING OF THE CONNECTORS AND STRIP LENGTH TO ACHIEVE THE CORRECT OVERALL LENGTHS.

NOTES: (UNLESS OTHERWISE SPECIFIED)

- A. MATERIAL:
- a. CONNECTOR SHELL - PEEK VICTREX 450GL30.
 - b. BACKSHELL - STAINLESS STEEL WITH VENT HOLE.
 - c. CONTACTS - BERYLLIUM COPPER ALLOY C17300. 0.00050 MIN. GOLD OVER NICKEL.
 - d. HARDWARE: STAINLESS STEEL, PASSIVATED.
 - e. PEEK BRAID - PEEK VICTREX GRADE TDS-450CA30 CARBON LOADED - SUPPLIED BY LIGO.
- B. CABLE 2 COND. 14 AWG, (STRANDED) WITH 2 LAYERS OF KAPTON TAPE. OVERALL 40AWG COPPER BRAID 50% COVERAGE - SUPPLIED BY LIGO. OVERALL PEEK BRAID MIN. 50% COVERAGE. OVERALL CABLE O.D. WILL BE 0.240 IN.
- C. CONNECTORS WILL BE SUPPLIED WITH HARDWARE. SCREWS SHOULD BE THE PROPER LENGTH FOR MATING.

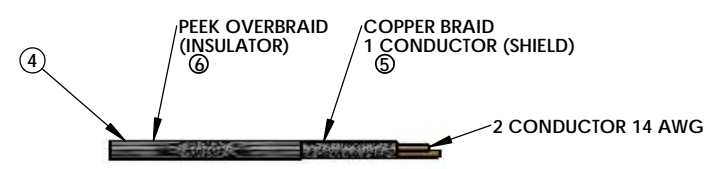

V3A-70 CABLE ASSEMBLY CIRCUIT SUMMARY

V-DB3 F/S1-70-2_PIN-94B8812 M/X

CABLE NAME	WIRE NAME	WIRE SIZE	LENGTH	FROM	TO
V3A-70					
	SHIELD	COPPER BRAID		J1 PIN 1	END OF CABLE
	W1	14 AWG	70in.	J1 PIN 2	J2
	W2	14AWG	70in.	J1 PIN 3	J3

V-DB3 F/S1-70-2_PIN-94B8812 M/X

STANDARD USE FOR THIS CABLE

SUBSYSTEM	AIR/VAC	STANDARD USE
SEI	IN-VAC	ISI ACTUATOR

NOTES AND TOLERANCES: (UNLESS OTHERWISE SPECIFIED)

- INTERPRET DRAWING PER ASME Y14.5-1994.
- REMOVE ALL SHARP EDGES, .005-.015, FOR MACHINED PARTS. ROUND ALL EDGES APPROXIMATELY R.02 FOR SHEET METAL PARTS.
- DO NOT SCALE FROM DRAWING.
- ALL MACHINING FLUIDS MUST BE FULLY SYNTHETIC, FULLY WATER SOLUBLE AND FREE OF SULFUR, SILICONE, AND CHLORINE.

DIMENSIONS ARE IN TOLERANCES: .XX ± .XXX ± ANGULAR ± °

MATERIAL: Material <not specified> FINISH: μ inch

CALENDAR: LIGO CALIFORNIA INSTITUTE OF TECHNOLOGY MASSACHUSETTS INSTITUTE OF TECHNOLOGY

SYSTEM: SEI SUB-SYSTEM: SEI

PART NAME: CUSTOM CABLE SPECIFICATION V3A-70

DESIGNER: B. ABBOTT JUL/13/2012 SIZE: DWG. NO. D1000918 REV. v3

DRAFTER: E. BROWN JUL/13/2012 CHECKER: APPROVAL:

SCALE: 1:1 PROJECTION: SHEET 1 OF 1