

8 7 6 5 4 3 2 1

REVISIONS			
REV.	DESCRIPTION	DATE	APPROVED
A	SEE ECN# D972613-A FOR CHANGE LIST	11-03-97	T. THOMPSON
B	SEE ECN# D972613-B FOR CHANGE LIST	12-01-97	T. THOMPSON

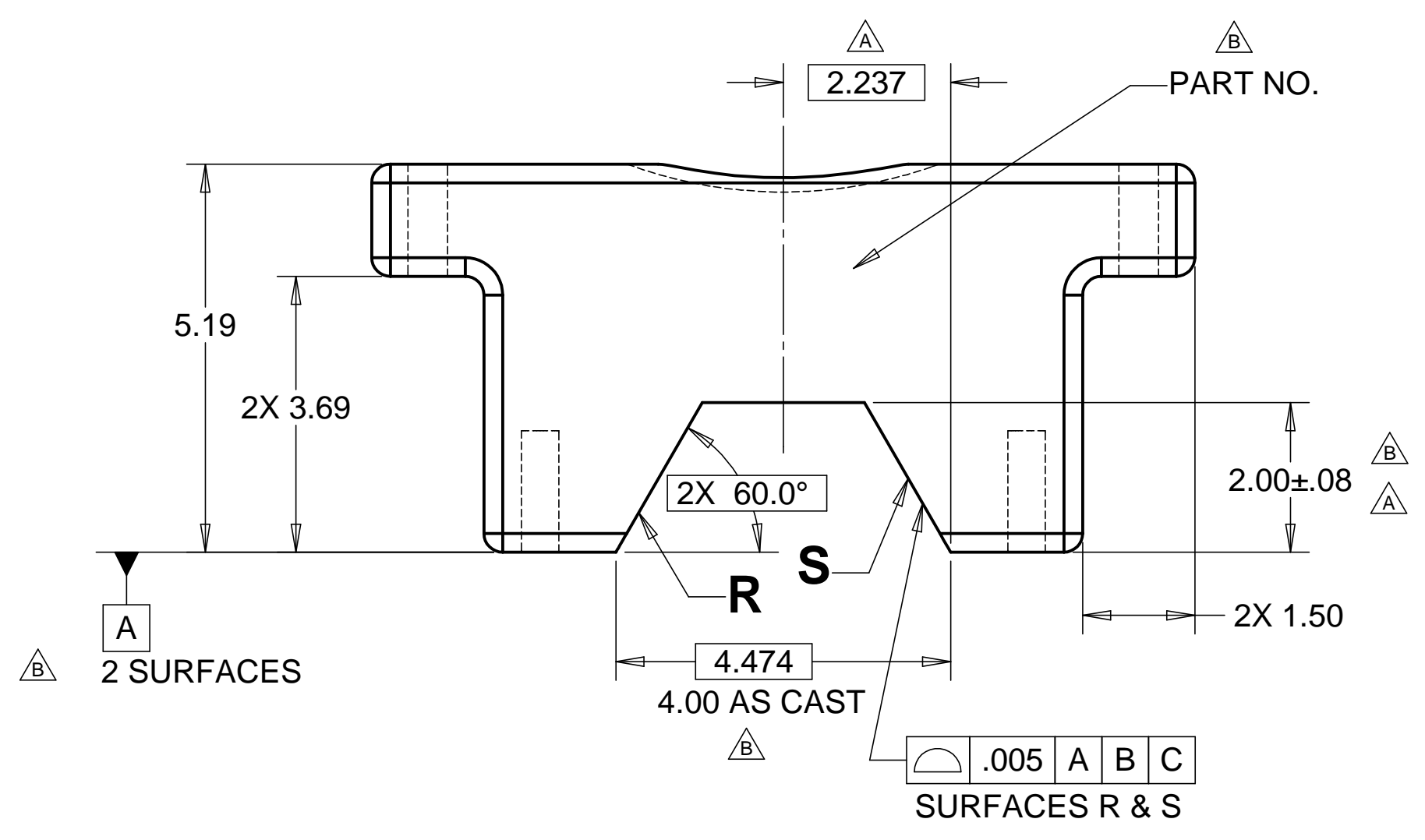

R.3 MAX
TYP FOR ALL NON
MACHINED EDGES

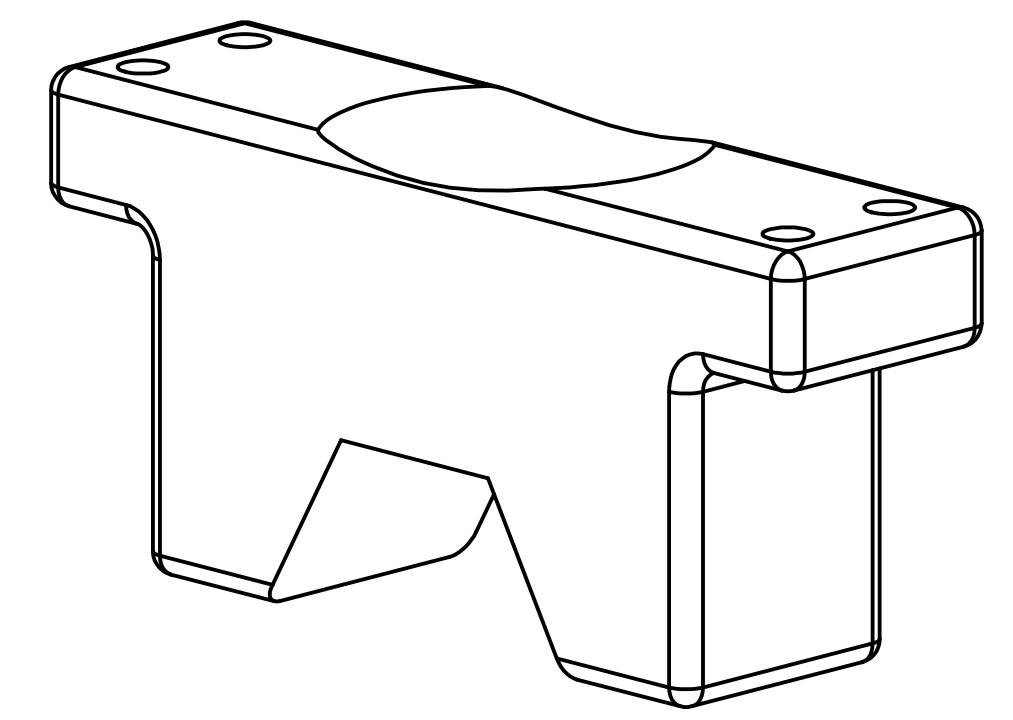
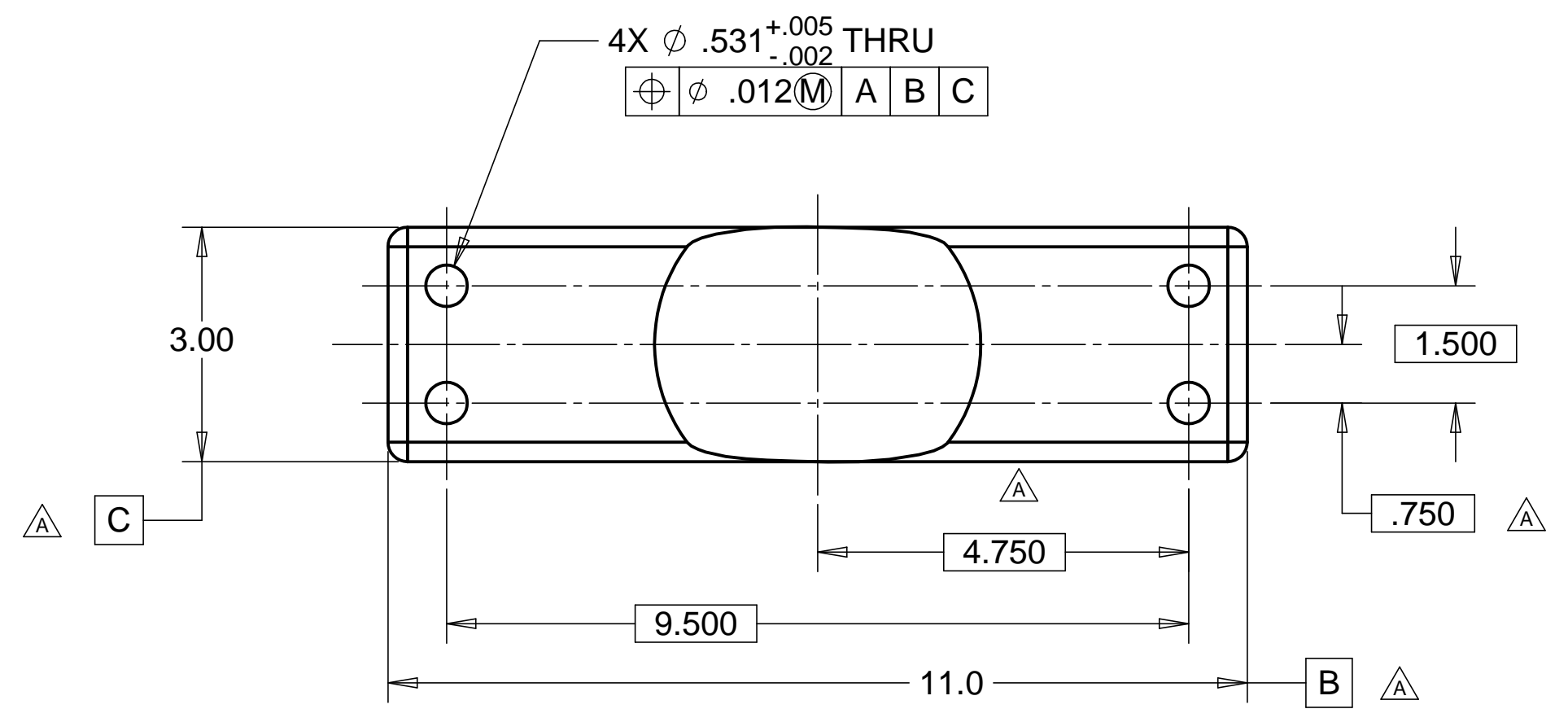
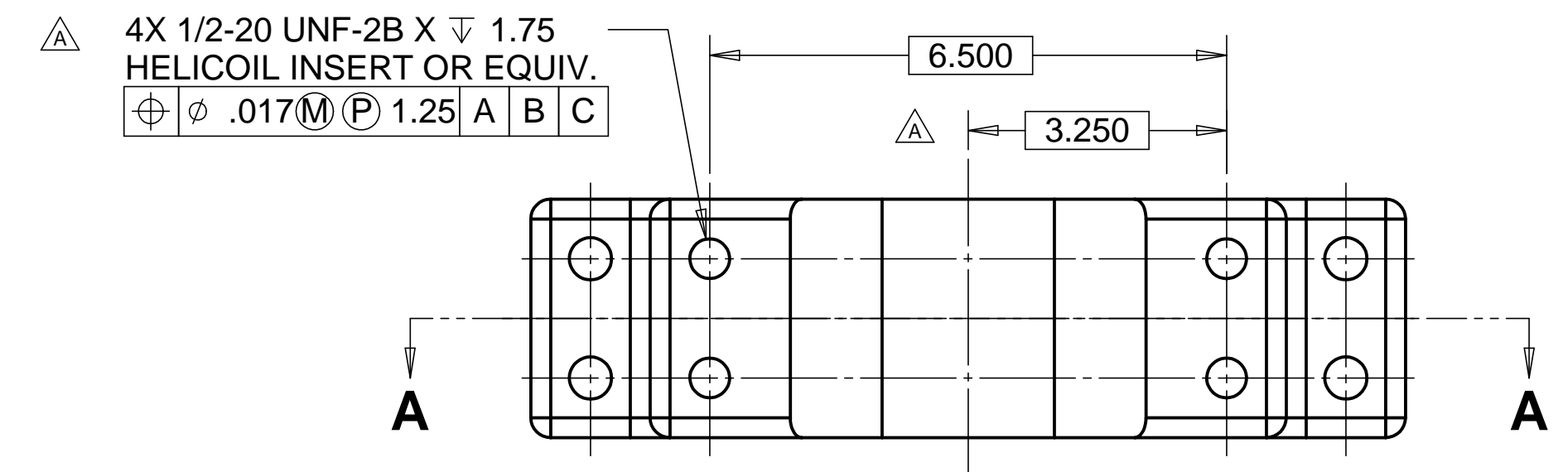
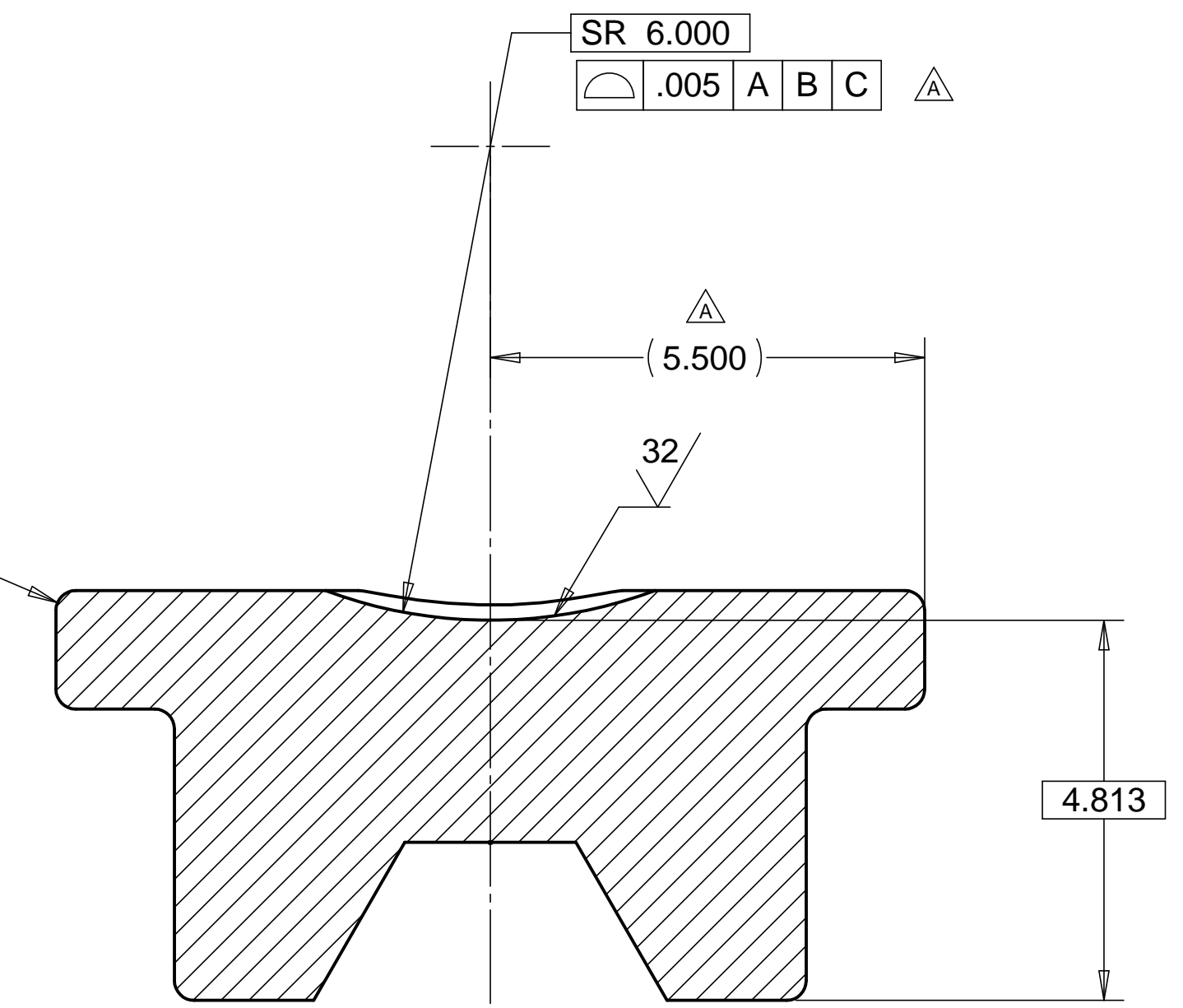

MATL: A356-T6 ALUM.
 WEIGHT: 10.9 lbs.

NOTES: UNLESS OTHERWISE SPECIFIED

- ALL DIMENSIONS IN INCHES
- DIMENSIONS AND TOLERANCING PER ASME Y14.5M-1994
- SURFACE TEXTURE PER ANSI/ASME B 46.1-1985
- REMOVE ALL BURRS AND BREAK SHARP EDGES TO A MAXIMUM OF .015
- ALL INSIDE CORNERS TO BE .015 RADIUS MAX
- COUNTERSINK 82 DEGREES ALL TAPPED HOLES TO MAJOR DIAMETER
- COUNTERSINK 82 DEGREES APPROXIMATELY .015 DEEP ALL DRILLED HOLES
- PARTS TO BE THOROUGHLY CLEANED TO REMOVE ALL OIL, GREASE, DIRT AND CHIPS
- PART NUMBER (DRAWING NO. PLUS DASH NO. PLUS SERIAL NO.) TO BE CLEARLY MARKED ON THE PART ITSELF.
- ALLOWABLE DRAFT ANGLE 2° MAX.

11. DIMENSIONS FROM MAX. DRAFT MATERIAL

PARTS LIST			
UNLESS OTHERWISE SPECIFIED: DIMENSIONS ARE IN INCHES -TOLERANCES-		CAD GENERATED DRAWING, DO NOT MANUALLY UPDATE DO NOT SCALE DRAWING	
DECIMALS .X = +/- .1 .XX = +/- .06 .XXX = +/- .010	ANGULAR = +/- 30° SURFACE FINISH = 250	HYTEC, INC TITLE LIGO HAM SUPPORT TUBE MOUNTING BASE	
FINISH	SIGNATURE	DATE	DWG. NO.
	ROGER L. SMITH	5-28-97	D972613
	ROGER L. SMITH	5-28-97	SIZE
	HARRY SALAZAR	7-10-97	D
	T. THOMPSON	7-10-97	SHEET NO.
	T. THOMPSON	7-10-97	1 of 1
PART NO. D972613-1	APPROVED	SCALE 1/2	REVISION B

8 7 6 5 4 3 2 1