



LIGO Laboratory / LIGO Scientific Collaboration

LIGO-T0900612-v2

LIGO

10/11/10

AdvLigo CDS
Design Overview

R. Bork

Distribution of this document:
LIGO Scientific Collaboration

This is an internal working note
of the LIGO Laboratory.

California Institute of Technology
LIGO Project – MS 18-34
1200 E. California Blvd.
Pasadena, CA 91125
Phone (626) 395-2129
Fax (626) 304-9834
E-mail: info@ligo.caltech.edu

Massachusetts Institute of Technology
LIGO Project – NW22-295
185 Albany St
Cambridge, MA 02139
Phone (617) 253-4824
Fax (617) 253-7014
E-mail: info@ligo.mit.edu

LIGO Hanford Observatory
P.O. Box 1970
Mail Stop S9-02
Richland WA 99352
Phone 509-372-8106
Fax 509-372-8137

LIGO Livingston Observatory
P.O. Box 940
Livingston, LA 70754
Phone 225-686-3100
Fax 225-686-7189

<http://www.ligo.caltech.edu/>

Table of Contents

1	<i>Introduction</i>	3
2	<i>Overview</i>	3
3	<i>System Hardware</i>	3
3.1	Timing Distribution System	4
3.2	Real-time Control Hardware	4
3.2.1	Computers.....	5
3.2.2	I/O Chassis.....	6
3.2.3	PCIe I/O Modules.....	6
3.3	DAQ Computers	6
3.4	Networking	7
3.5	Computer and Networking Rack Layouts	8
3.6	Physical Environment Monitoring (PEM)	8
4	<i>CDS Software</i>	9
4.1	Operating Systems	10
4.2	Frontend Computer Software	10
4.2.1	Real-time Executable.....	11
4.2.2	EPICS State Notation Language (SNL).....	11
4.2.3	EPICS Database Records.....	12
4.2.4	AWGTPMAN.....	12
4.2.5	DAQ Network Driver.....	13
4.3	Data Acquisition System Software	13

1 Introduction

The purpose of this document is to provide an overview of the AdvLigo Control and Data System (CDS).

2 Overview

The primary focus of this document is a description of the CDS infrastructure to be provided for aLIGO. This includes standard interface electronics, computing and networking systems (section 3), and CDS standard software packages (section 4). This document also provides links to more detailed documentation on the various standard CDS components.

3 System Hardware

The following figure depicts the primary hardware components of the AdvLigo CDS system. These components include:

- 1) Timing Distribution System: Slaved to a Global Positioning System (GPS) receiver, this system distributes the clocks necessary to synchronize all of the CDS systems.
- 2) Multi-processor / multi-core computers, with a real-time operating system, used to perform real-time control algorithms and synchronous data acquisition. These computers are commonly referred to as Front End (FE) computers.
- 3) PCI Express (PCIe) based I/O chassis to house analog to digital conversion devices. These units also contain a PCIe based uplink to connect to the FE computers. This is a fiber link, which allows the I/O chassis to be located up to 300m from the FE computer.
- 4) Data Acquisition (DAQ) data concentrator. All FE computers send their DAQ data to a central computer, which combines all of the data and broadcasts it out to the remainder of the DAQ and Diagnostic Monitoring Tool (DMT) computers.
- 5) DAQ Network Data Server (NDS). These computers provide live or stored DAQ data to operator stations. Certain units are also designated to provide data outside of CDS via a general computing network.
- 6) DAQ FrameWriters. These units write data to local disk and to the larger LIGO Data Analysis System (LDAS) disk farm.
- 7) DMT computers. These units run Interferometer diagnostics and characterization software.
- 8) EPICS Gateway. Central computers which route all EPICs data between operator systems and the FE computers.
- 9) Various networks to link all of the computer systems together.

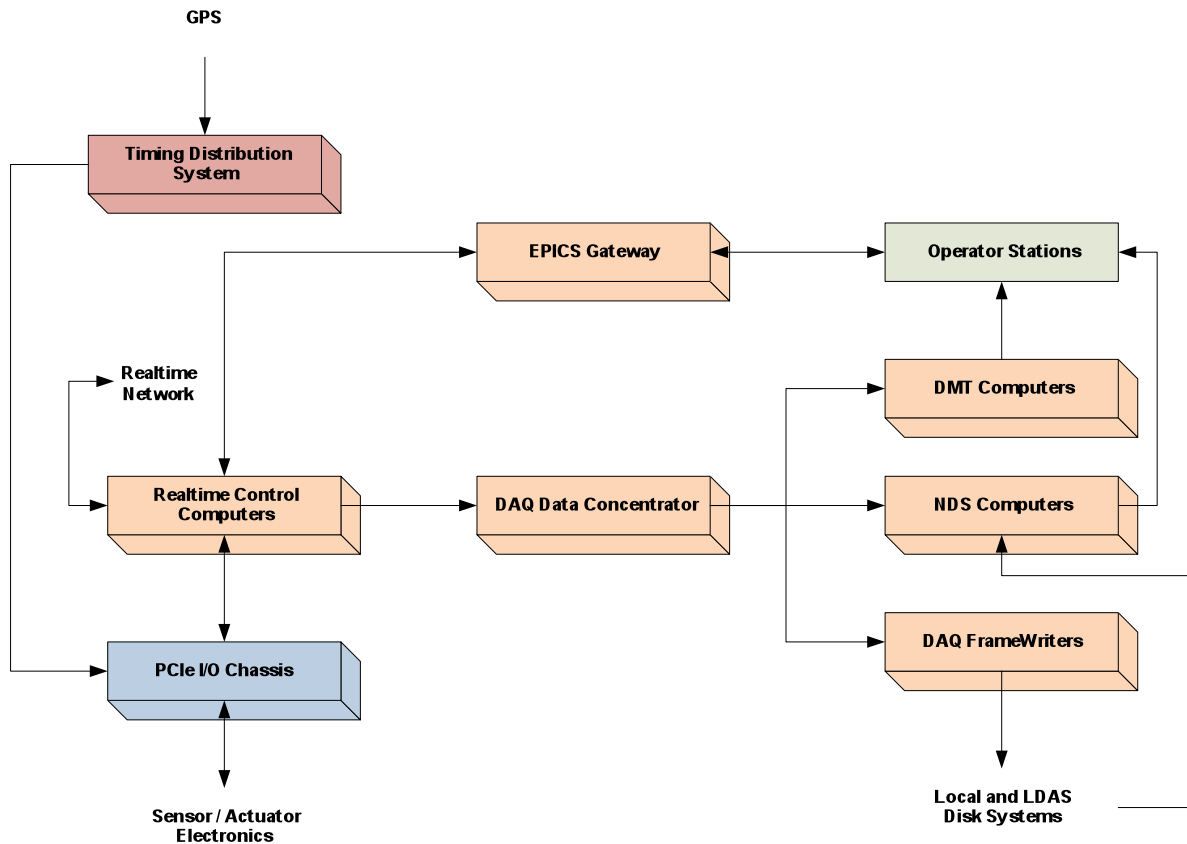

Figure 1: CDS Hardware Overview

3.1 Timing Distribution System

All LIGO CDS Input/Output (I/O) modules receive a synchronous 65536Hz clock from a central Timing Distribution System (TDS). This TDS is synchronized with the Global Positioning System (GPS), which allows synchronization between multiple sites. The TDS distributes the clocks, via fiber optic links, to the many LIGO I/O chassis locations.

The AdvLigo TDS design was a collaborative effort between LIGO and Columbia University. The TDS is now being manufactured and provided under subcontract to Columbia University. Documentation on this system can be found at [Timing System Document Map](#).

3.2 Real-time Control Hardware

AdvLigo real-time control systems (defined here as all systems which must provide control, monitoring and data acquisition capabilities at >256 sample/sec) will be built using a common architecture, as depicted in the following diagram. The primary components of this architecture are:

- 1) Multi-processor, multi-core, server class computers.
- 2) An I/O chassis, which contains a PCIe bus with either a 17 slot PCIe bus.
- 3) PCIe, over fiber, link to allow the computer and I/O chassis to be separated by as much as 300m.

For AdvLigo, at the corner stations, the computers will be rack mounted in the Mass Storage Room (MSR), located adjacent to the control room. The I/O chassis will be located, as presently at LLO, in the high bay adjacent to the LVEA. Computer and I/O chassis locations for the end stations are TBD. Preliminary rack layouts for computer and networking equipment are shown in section 3.5.

The following subsections describe the real-time systems in general terms. The specific implementation and configuration of the real-time hardware for control of specific AdvLigo subsystems is the responsibility of each subsystem and not within the scope of this document.

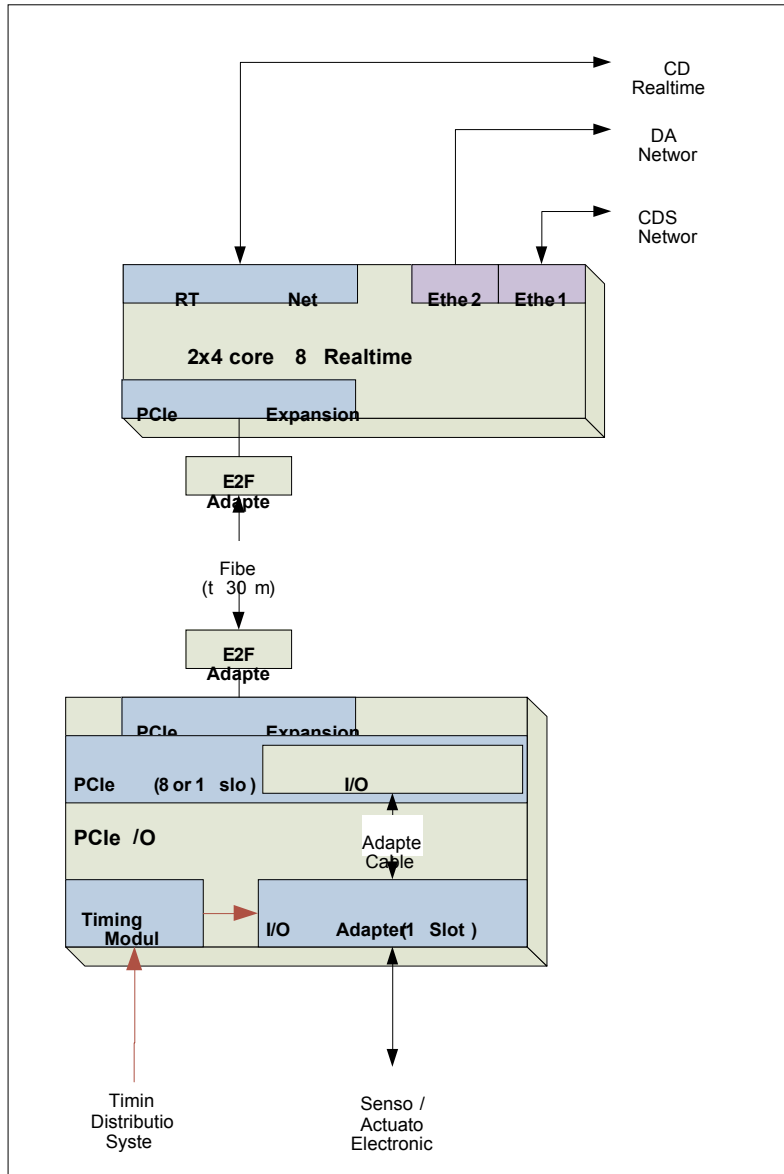

Figure 2: Standard Real-time Computing and I/O Design

3.2.1 Computers

The computer may be any 64 bit, x86 based unit, with a minimum of two computer cores available. For most AdvLigo applications, this will be a 1U rack mount unit, with two internal GigE Ethernet

ports and four PCIe expansion slots. Specifics for computers to be installed in the initial aLIGO build are described in CDS computer /Networking rack layouts [LIGO-T1000588](#).

Note that computers used for real-time control must be tested for real-time performance prior to procurements. It has been found, over several years of testing new models, that not all motherboards are created equal. With certain models, it was found that real-time tasks still received unexpected interrupts, causing various delays at uncertain times which made these motherboards unusable for these applications. It has also been found that not all BIOS on these machines are suitable in that they will not provide enough I/O card mapping to support the I/O chassis.

3.2.2 I/O Chassis

PCI Express (PCIe) has been chosen as the I/O module standard for aLIGO CDS. To house these modules and provide interfaces to sensor/actuator electronics, a custom PCIe I/O chassis has been designed (see [LIGO-T0900613](#)). This chassis is a combination of a commercial PCIe backplane, with fiber uplink capabilities, and custom I/O interfaces for the connection of field cabling and TDS clock signals.

3.2.3 PCIe I/O Modules

The CDS realtime software provides support for a number of I/O modules, which presently includes:

- 1) [ADC - 32 channels, 16 bit](#) (In-house test documentation [T070213](#))
- 2) [ADC - 32 channels, 18 bit](#) (New, lower noise 18 bit ADC under development (early 2010)).
- 3) [DAC - 8 channels, 18bit](#) (In-house test documentation [G0900510](#))
- 4) [DAC - 16 channels, 16 bit](#) (In-house test documentation [T070264](#))
- 5) [Digital I/O](#) (various models on the linked page)

3.3 DAQ Computers

The process of data acquisition begins with the digitization and processing of data within the real-time control systems. This data is then transmitted, via Ethernet, to DAQ computers which:

- 1) Receive and combine data from all real-time FE computers (Data Concentrator).
- 2) Format and write the data to disk (FrameWriter).
- 3) Provide access to data, both in the form of real-time data feeds and data from disk (Network Data Server).

A basic layout and interconnections of these computers are shown in the following figure. One such system will be provided for each interferometer (IFO). DAQ computers and disk drive system specifics are further discussed in [LIGO-T1000588](#).

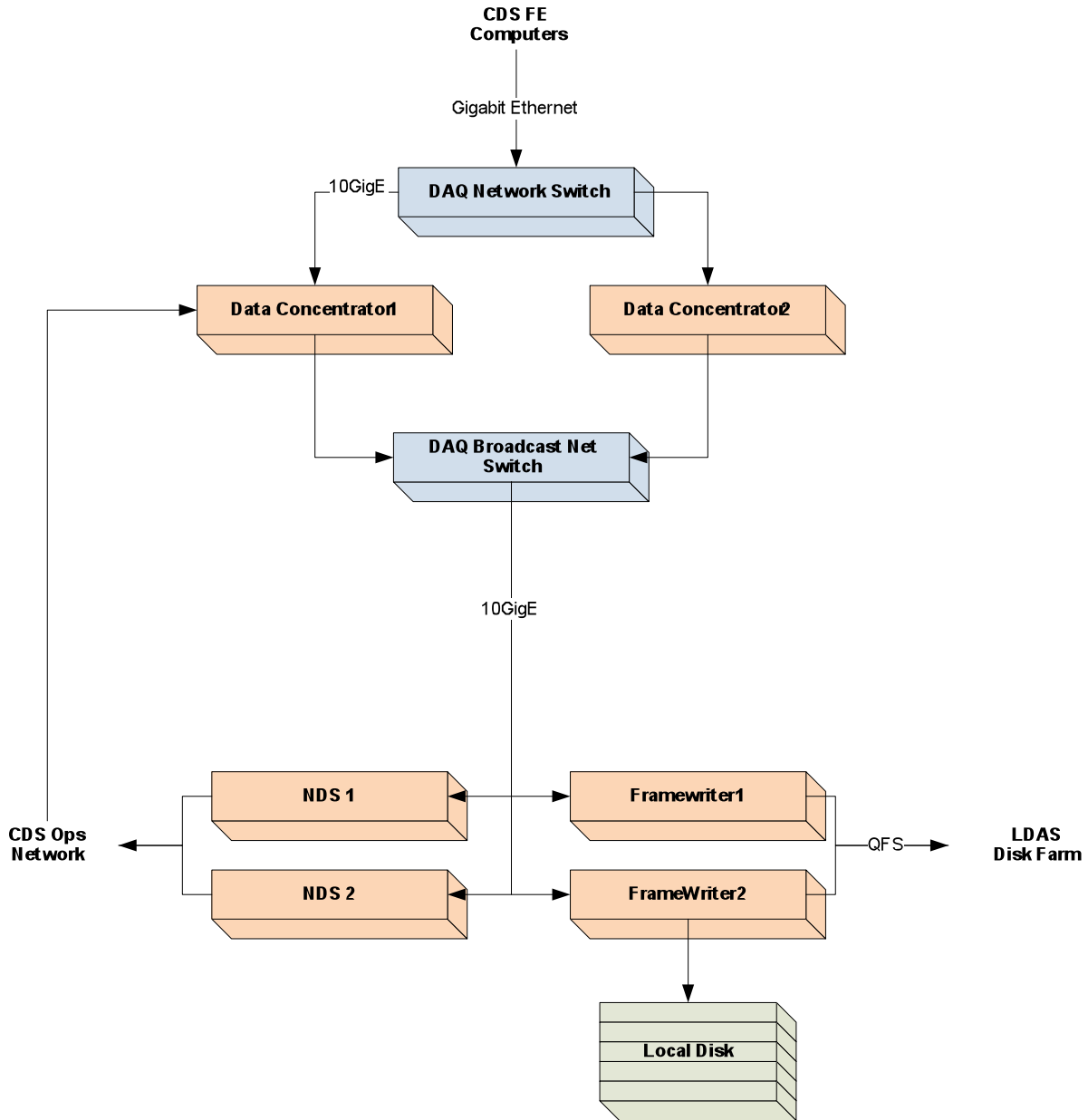

Figure 3: DAQ Computer Layout

3.4 Networking

CDS provides internal, private networks for communications between CDS computers. For all EPICS and DAQ network traffic, standard Ethernet is used. The real-time computers must also be interconnected via networks which provide low-latency and deterministic timing. Details of these networks are provided in [LIGO-T0900602](#).

3.5 Computer and Networking Rack Layouts

CDS computers and networking equipment are to be housed in 19" equipment racks. At the corner station, racks are to be located in the Mass Storage Room (MSR). At the end stations, racks locations are TBD. Details of CDS computer and networking rack layouts can be found in LIGO-T1000588.

3.6 Physical Environment Monitoring (PEM)

As part of the aLIGO DAQ, equipment is to be provided to interface and acquire PEM signals directly. In the same fashion as other CDS control systems, the PEM design employs the aLIGO CDS standard equipment. Details of the PEM design are documented in [LIGO-T0900622](#).

4 CDS Software

The following figure depicts the primary software modules employed in CDS. These software programs fall into the following categories:

- 1) Offline: Software tools used to develop and support on-line systems. This includes:
 - a. Real-time Code Generator: A combination of Matlab Simulink models and Perl script parsers used to develop real-time control applications.
 - b. Foton: Tool used to design IIR filters for the operational real-time systems.
- 2) Real-time software: The real-time executable software used for synchronous control and monitoring of LIGO systems.
- 3) Data Acquisition (DAQ): Includes the software used to acquire, store and distribute data.
 - a. DAQ real-time acquisition software, built into every real-time executable.
 - b. DAQ network software, which moves data from the real-time computers to the DAQ system.
 - c. Daqd: Data acquisition software threads, which perform various tasks, depending on the compile options:
 - i. Collect all data from real-time systems and broadcast that combined data to upstream DAQ computers.
 - ii. Write data to disk using the LVC standard Frame Library.
 - iii. Provides both functions above in a stand-alone configuration ie runs on the same computer as the real-time code for stand-alone control systems.
 - d. Network Data Server (NDS): Software which provides data, on request, to various other operational support tools. This data may be from archive or live data feeds.
- 4) Diagnostics: A number of software tools provide diagnostic information for use in operations. An overview is provided in [LIGO-T990018](#).
 - a. Diagnostic Test Tools (DTT). ([LIGO-T990013](#)).
 - b. Arbitrary Waveform Generator / Test Point Manager (AWGTPMAN). ([LIGO-T990013](#)).
 - c. Dataviewer
 - d. Awgstream
- 5) Scripting Tools
 - a. mDv ([LIGO-G070375](#))
 - b. TDS
 - c. EZCA
- 6) Operational Support
 - a. EPICS ([EPICS Home Page](#))
 - b. Conlog
 - c. Stats

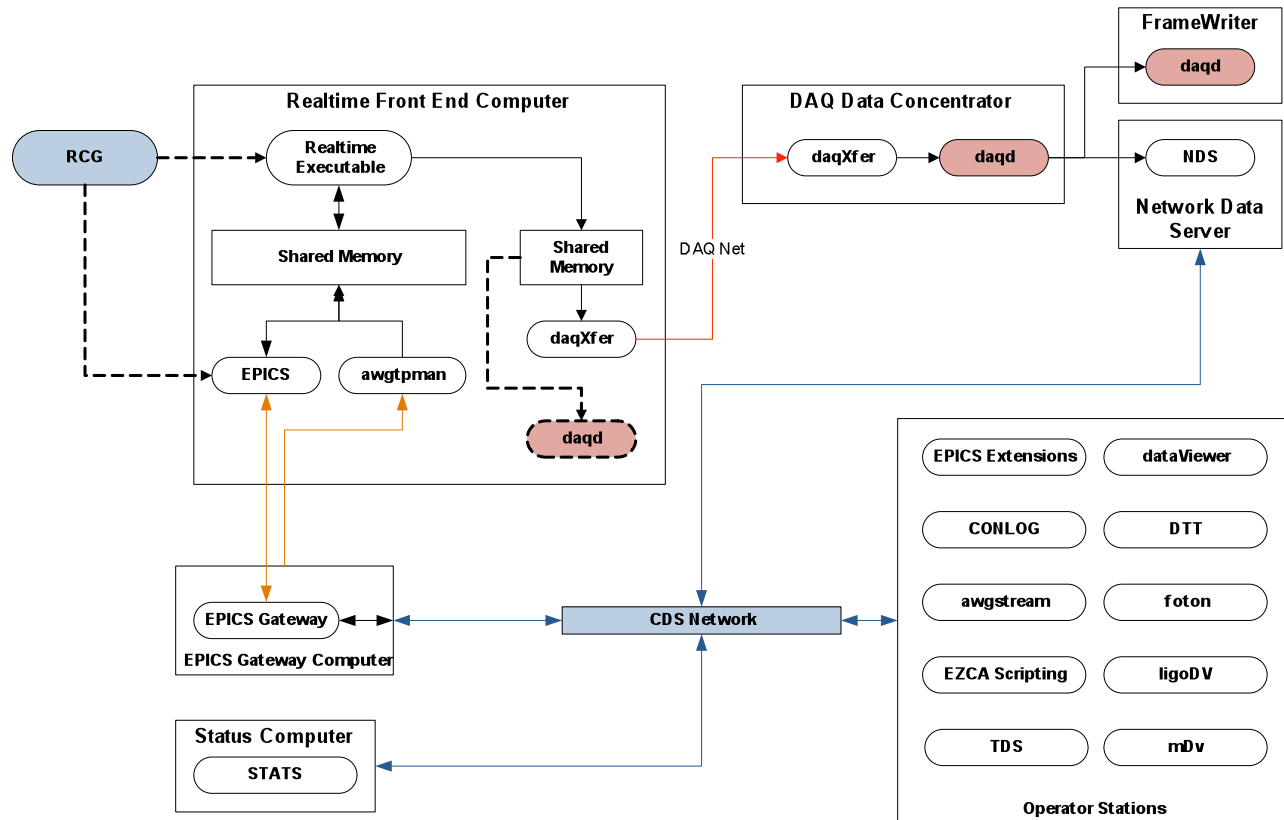

4.1 Operating Systems

Initial development was performed using a commercial real-time Linux package. As of August, 2010, a patch was developed by the CDS group to use GPL Linux for aLIGO real-time applications. All present and future CDS real-time development is based on this patch, presently incorporated in Linux kernel 2.16.34.

For remaining systems, the standard is CentOS Linux. Presently, the only exception to this is the computer which interfaces the CDS FrameWriters to the LDAS disk arrays. This computer requires Sun Solaris to handle the QFS interface.

4.2 Frontend Computer Software

Control applications for the various AdvLigo subsystems will be defined and built using the CDS Real-time Code Generator (RCG). The RCG allows application developers to define applications via the graphical editor of Matlab Simulink. The key components of the RCG are, as shown in blue in the following diagram:

- 1) A set of CDS defined and supported Matlab Simulink parts (CDS Matlab Parts Library). This includes custom and standard Simulink parts. This library is discussed in detail in the [RCG User's Guide](#). This reference contains usage of, as well as code generated by, each part.
- 2) RCG common real-time code source library.

- 3) The RCG Perl scripts. When ‘make’ is invoked, the RCG Perl scripts read and parse the Matlab .mdl file, produced by step 1 above. The outputs of the make include:
 - a. Supporting runtime files, highlighted in green on the left of the following figure.
 - b. An EPICS database, for communications between the application and the CDS network.
 - c. An EPICS executable, for communications between the EPICS database and the real-time application, via shared memory.
 - d. A real-time executable.
 - e. Supporting files, which include DAQ, GDS and filter lists and a base set of EPICS MEDM operator displays.

4.2.1 Real-time Executable

A common set of real-time source code is compiled into all aLIGO real-time control applications. Requirements for this software are listed in [LIGO-T0900603](#).

The real-time executable is compiled as a single code thread, designed to run on a single core of a multi-CPU, multi-core computer. The primary source files compiled into this executable are:

- 1) The user application, as parsed from the Matlab .mdl file and written as C code by the RCG.
- 2) The runtime sequencer (RTS). This code performs the timing, scheduling and I/O functions for all real-time applications. A description of this code can be found in [LIGO-T0900607](#).
- 3) IIR filtering software. IIR filters are used extensively in the real-time control applications. A CDS Standard Filter Module (SFM) was developed to perform these filtering tasks. More information on the SFM software can be found in [LIGO-T0900606](#).
- 4) Inter-process and Inter-computer communications. Various real-time control tasks must exchange data, either via shared memory within a single computer or via the FE control network between computers. The software designed to perform this function is described in [LIGO-T1000587](#).
- 5) Data acquisition and Global Diagnostics Support. A common code set has been developed to handle data acquisition and global diagnostics for all real-time systems. More information on this software module can be found in [LIGO-T0900638](#).

4.2.2 EPICS State Notation Language (SNL)

To provide an interface between the real-time executable and the EPICS database, a template program, using [EPICS SNL](#), is provided as part of the RCG. The executable runs under Linux on a non-real-time core, exchanging data with the real-time process and EPICS database records.

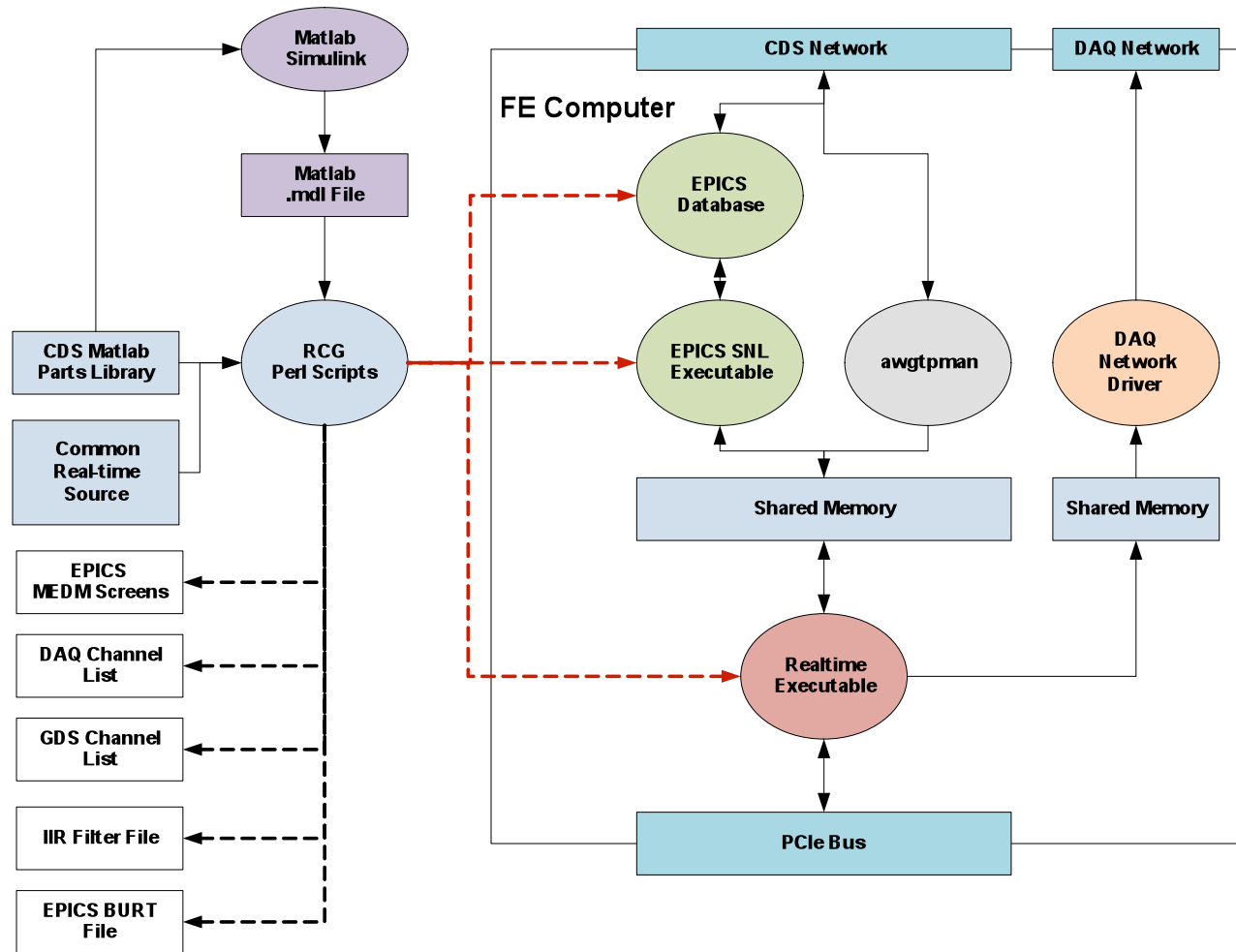

4.2.3 EPICS Database Records

The EPICS database records, along with the EPICS Channel Access Server capabilities, provide the mechanism to interface data between the CDS networks and the EPICS SNL software. This allows data exchange with operator stations running various EPICS extensions, which, in turn, provide graphical and other interface tools for operator use.

4.2.4 AWGTPMAN

This is essentially the same software used in initial LIGO to set test points and produce test injection signals. The primary changes made are:

- 1) Port to Linux.
- 2) Interface to the real-time executable is now via shared memory, whereas initial LIGO software interface was via the CDS reflected memory network.
- 3) There is one awgtpman task associated with each real-time executable. In initial LIGO, there is one awgtpman per interferometer.

4.2.5 DAQ Network Driver

The real-time DAQ software writes its data to shared memory on the FE computers. For transmission of this data to the DAQ data concentrators via Ethernet, a separate, non-real-time program is provided. Details of this software can be found in TBD.

4.3 Data Acquisition System Software

The DAQ software is responsible for:

- 1) Collecting data from all real-time control and acquisition computers.
- 2) Formatting the data into standard LIGO Frame format (see [LIGO T970130](#)).
- 3) Writing the formatted data to disk, both locally and to LDAS provided disk systems.
- 4) Serving data, either from disk or real-time, to various CDS diagnostic and monitoring programs running on CDS control room computers.

The software which perform these functions are referred to as the FrameBuilder software, which gathers and writes data, and the Network Data Server (NDS), which serves data on request via CDS networks. A more detailed description of the DAQ software can be found in [LIGO-T0900636](#).