

# LIGO Laboratory / LIGO Scientific Collaboration

**LIGO-T0900236-v1**    **Advanced LIGO UK**    7 May 2009

---

## UIM Drive Unit Test Plan

---

R. M. Cutler, University of Birmingham

Distribution of this document:  
Inform [aligo\\_sus](mailto:aligo_sus)

This is an internal working note  
of the Advanced LIGO Project, prepared by members of the UK team.

**Institute for Gravitational Research  
University of Glasgow**

Phone +44 (0) 141 330 5884

Fax +44 (0) 141 330 6833

E-mail [k.strain@physics.gla.ac.uk](mailto:k.strain@physics.gla.ac.uk)

**Engineering Department**

**CCLRC Rutherford Appleton Laboratory**

Phone +44 (0) 1235 445 297

Fax +44 (0) 1235 445 843

E-mail [J.Greenhalgh@rl.ac.uk](mailto:J.Greenhalgh@rl.ac.uk)

**School of Physics and Astronomy**

**University of Birmingham**

Phone +44 (0) 121 414 6447

Fax +44 (0) 121 414 3722

E-mail [av@star.sr.bham.ac.uk](mailto:av@star.sr.bham.ac.uk)

**Department of Physics**

**University of Strathclyde**

Phone +44 (0) 1411 548 3360

Fax +44 (0) 141 552 2891

E-mail [N.Lockerbie@phys.strath.ac.uk](mailto:N.Lockerbie@phys.strath.ac.uk)

<http://www.ligo.caltech.edu/>

<http://www.physics.gla.ac.uk/igr/sus/>

<http://www.sr.bham.ac.uk/research/gravity/rh.d.2.html>

[http://www.eng-external.rl.ac.uk/advligo/papers\\_public/ALUK\\_Homepage.htm](http://www.eng-external.rl.ac.uk/advligo/papers_public/ALUK_Homepage.htm)

# UIM DRIVE COMPLETED UNIT TEST PLAN

Unit.....Serial No .....

Test Engineer .....

Date .....

Drive Card ID.....

Monitor Card ID .....

## Contents

1. Description
2. Test Equipment
3. Inspection
4. Continuity Checks
5. Test Set Up
6. Power
7. Relay operation
9. Current Monitor Tests
9. Voltage Monitor Tests
10. Corner Frequency Tests
11. Noise Monitor Tests
12. Distortion
13. Final Assembly Tests

## 1. Description

The UIM Driver Unit will be used to control the mirror position in the Advanced LIGO Gravity wave experiment.

It controls the current in the coil which provides the magnetic force which controls the position of the UIM mirror in a Quad assembly. It works in conjunction with the OSEM coil and position sensor units. One UIM unit controls four OSEMs.

The UIM Coil Drive Unit contains a Coil Drive board and a Monitor board. The Monitor Board monitors the Output voltage, Output Current, RMS Current and Output Noise from the unit.

The UIM Driver Unit also passes the amplified signals from the Photodiodes, which detect the position of the UIM mirror, back to the control electronics without processing them in any way.

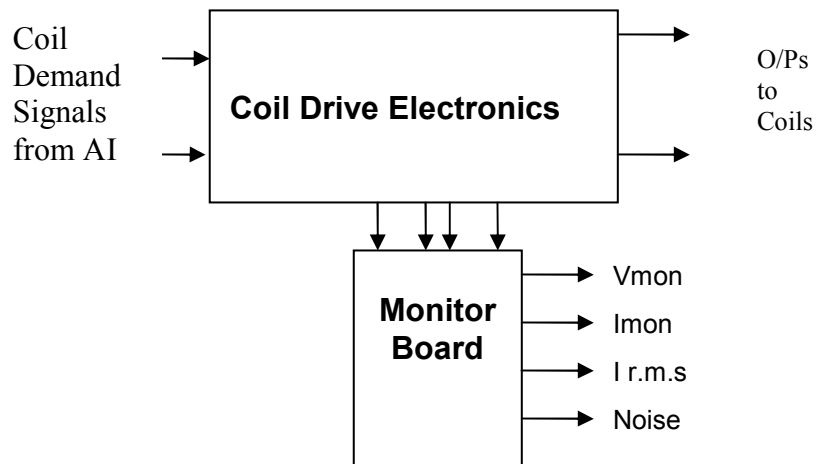

**FIG. 1 UIM Driver Unit Block Diagram**

Each UIM Driver Unit consists of four identical differential coil drive channels. It also contains the monitor board which monitors the output voltage, current, r.m.s current and noise from each channel

Unit.....Serial No .....  
Test Engineer .....  
Date .....

## 2. Test Equipment

Power supplies (At least +/- 20v variable, 1A)  
Signal generator (capable of delivering 10v peak, 0.1Hz to 10 KHz)  
Digital oscilloscope  
Analogue oscilloscope  
Agilent Dynamic Signal Analyser (or similar)  
Low noise Balanced Driver circuit  
Relay test box

Record the Models and serial numbers of the test equipment used below.

Unit (e.g. DVM)	Manufacturer	Model	Serial Number

Unit.....Serial No .....  
Test Engineer .....  
Date .....

### **3. Inspection**

Remove the lid of the case.

#### **Workmanship**

Inspect the general workmanship standard and comment:

#### **Links:**

Check that links W3, W4 and W5 are present on each channel of the Drive board. If not, connect them.

Unit.....Serial No .....

Test Engineer .....

Date .....

#### 4. Continuity Checks

Use a multi-meter to check the connections below.

##### Photodiode outputs

Pd Out to AA	SIGNAL	DESCRIPTION	Pd in from Sat	OK?
1	PD1P	Photodiode A+	1	
2	PD2P	Photodiode B+	2	
3	PD3P	Photodiode C+	3	
4	PD4P	Photodiode D+	4	
5	0V			
6	PD1N	Photodiode A-	14	
7	PD2N	Photodiode B-	15	
8	PD3N	Photodiode C-	16	
9	PD4N	Photodiode D-	17	

##### LED Monitors

LED Mon	SIGNAL	Monitors:	In from Sat	OK?
1	Imon1P	Current Source 1+	5	
2	Imon2P	Current Source 2+	6	
3	Imon3P	Current Source 3+	7	
4	Imon4P	Current Source 4+	8	
5	0V			
6	Imon1N	Current Source 1-	18	
7	Imon2N	Current Source 2-	19	
8	Imon3N	Current Source 3-	20	
9	Imon4N	Current Source 4-	21	

##### Power Supply to Satellite box

In from Sat	SIGNAL	DESCRIPTION	DC in Connector	OK?
9	V+	+17v Supply	A1	
10	V+	+17v Supply	A1	
11	V-	-17v Supply	A3	
12	V-	-17v Supply	A3	
13	0V	Return	A2	
22	0V	Return	A2	
23	0V	Return	A2	
24	0V	Return	A2	
25	0V	Return	A2	

## 5. TEST SET UP

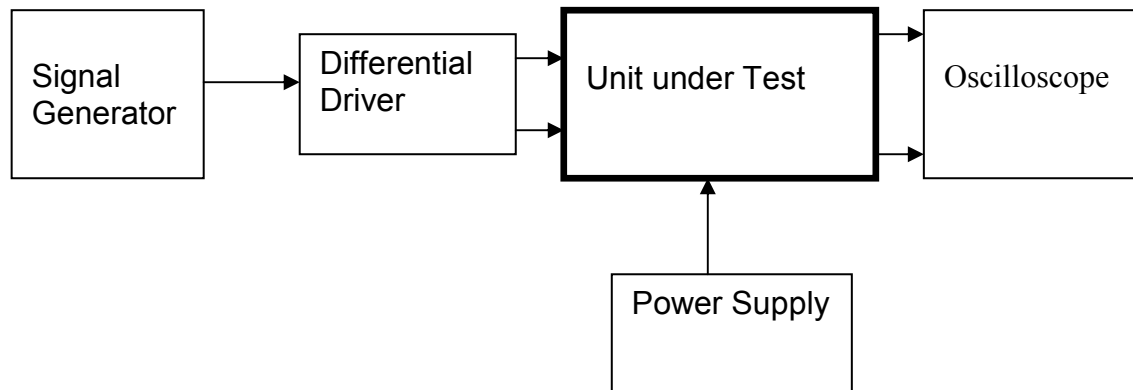

Note:

(1) Input signal to differential amplifier is generally stated in the tests below. There is therefore an inherent gain of 2 in the system.

(2) Some signal generators will indicate 1vpk/pk when the output is in fact 1v Peak into the high impedance Differential driver used. The test procedure refers to the actual voltage out of the signal generator.

### Connections:

#### Differential signal inputs to the Drive Input of the unit under test:

Drive Input pins 1, 2, 3, 4 = positive input

Drive Input pins 6, 7, 8, 9 = negative input

Drive Input pin 5 = ground

#### Power (depending on connector availability)

Pd In from Sat pin 9, 10 = +16.5v                      or DC in A1

Pd In from Sat pin 11, 12 = -16.5                      or DC in A3

Pd In from Sat pins 22, 23, 24, 25 = 0v                      or DC in A2

#### Coil Drive Outputs

Ch1+ = Coil out to Sat pin 1

Ch1- = Coil out to Sat pin 9

Ch2+ = Coil out to Sat pin 3

Ch2- = Coil out to Sat pin 11

Ch3+ = Coil out to Sat pin 5

Ch3- = Coil out to Sat pin 13

Ch4+ = Coil out to Sat pin 7

Ch4- = Coil out to Sat pin 15

## Voltage, Current and R.M.S monitors

1	Voltage Monitor 4
2	Current Monitor 4
3	R.M.S Current 4
4	Voltage Monitor 3
5	Current Monitor 3
6	R.M.S Current 3
7	Voltage Monitor 2
8	Current Monitor 2
9	R.M.S Current 2
10	Voltage Monitor 1
11	Current Monitor 1
12	R.M.S Current 1
13 to 25	0v

## Noise Monitor

1	Channel 1 Noise Monitor
2	Channel 2 Noise Monitor
3	Channel 3 Noise Monitor
4	Channel 4 Noise Monitor
5 to 9	0v



Unit.....Serial No .....  
Test Engineer .....  
Date .....

## 6. Power

**Check the polarity of the wiring from the 3 Pin Power Connector, to each of the boards. Viewed from the back of the unit:**

A1	Left pin	Positive	White wire
A2	Middle pin	RTN	Black wire
A3	Right pin	Negative	Green wire

**If this is correct,**  
Connect power to the unit  
Set the supplies to 16.5v  
Turn on

Record supply currents:

+ 16.5 supply current (mA)	- 16.5 supply current (mA)

Check that all power LEDs are illuminated.

LEDs	Plus	Minus
Front Panel		
Rear Panel		

If the power supplies are correct, proceed to the next section.

Unit.....Serial No .....

Test Engineer .....

Date .....

## 7. Relay Operation

Connect the test unit to the Binary IO inputs.

Operate switches and check that LEDs are on when the relays are switched on, and off when they are switched off:

Relay	LED Operation					
	Filter 1		Filter 2		Filter 2	
	ON	OFF	ON	OFF	ON	OFF
Ch1						
Ch2						
Ch3						
Ch4						

This indicates that the relays are operating, and that the talk back contacts work OK.

Unit.....Serial No .....  
 Test Engineer .....  
 Date .....

### 8. Current Monitor tests

The purpose of this test is to perform a functionality test on the current monitor and RMS circuits.

Connect the 39 ohm dummy loads to the coil drive output. Connect the differential driver to the input, fed by the signal generator. Set the signal generator to 4v at 100 Hz.

Switch out the filters.

Use the true r.m.s meter to measure the r.m.s voltage between test points TP7 and TP11. Adjust the input drive unit until this voltage is 3v r.m.s.

Connect a scope probe to each end of one of the load resistors. Set up the scope to differentially observe the voltage across the load resistor. Check that it is a sine wave.

Measure and record output from each current monitor, and each of the RMS circuits. Set the meter to r.m.s for the “current monitor” readings (ac signal), and to dc when measuring the r.m.s. outputs (dc signal).

#### 1v across load resistor

Channel	Monitor Connector	Parameter	Theoretical Value	Measured Value	Pass/Fail
1	Pin 11	Current Monitor	0.95 v r.m.s		
	Pin 12	RMS Current	0.95 v dc		
2	Pin 8	Current Monitor	0.95 v r.m.s		
	Pin 9	RMS Current	0.95 v dc		
3	Pin 5	Current Monitor	0.95 v r.m.s		
	Pin 6	RMS Current	0.95 v dc		
4	Pin 2	Current Monitor	0.95 v r.m.s		
	Pin 3	RMS Current	0.95 v dc		

Unit.....Serial No .....

Test Engineer .....

Date .....

### 9. Voltage Monitor tests

The purpose of this test is to verify and calibrate the Voltage Monitor circuit on each channel.

Switch all filters out. Remove the dummy loads and make differential voltage output measurements on the coil drive outputs TP7 and TP11 at 100 Hz. Adjust the signal generator to give a voltage to 3v r.m.s on the coil drive outputs.

Record the peak voltage on each Voltage Monitor pin, and check against the theoretical figure.

Channel	Coil Drive Output pins	Voltage Monitor socket Pin	Monitor output?	Expected value	OK?
1	Pins 1,9	Pin 10		0.95v to 1.05v	
2	Pins 3,11	Pin 7		0.95v to 1.05v	
3	Pins 5,13	Pin 4		0.95v to 1.05v	
4	Pins 7, 15	Pin 1		0.95v to 1.05v	

Measurements may be used using a 25 way break out box, or a 25 way connector on the V, I and r.m.s connector.

## 10. Corner frequency tests

The purpose of this test is to verify that the frequency response of each filter stage of each channel is correct. There are two possible ways of performing this test depending on available equipment. Either 8.1 or 8.2 should be conducted (it is not necessary to do both).

### 10.1 Using a Signal Generator

Apply a signal to the input, amplitude 1v peak, Frequency 100Hz via the differential driver, to the Drive Input.

Switch out all the filter stages. Measure and record the peak differential output between the outputs of each channel, using two oscilloscope channels in differential mode.

	Coil Drive output pins	Pk/pk Output	Specification	Pass/Fail
<b>Ch1</b>	1 and 9		4.8v to 5v	
<b>Ch2</b>	3 and 11		4.8v to 5v	
<b>Ch3</b>	5 and 13		4.8v to 5v	
<b>Ch4</b>	7 and 15		4.8v to 5v	

Switch in each filter in turn and measure and record the peak output at 1Hz, 10 Hz, and 1 KHz.

**1Hz**

	Coil Drive output pins	F1	F2	F3	Specification	Pass/Fail
<b>Ch1</b>	1 and 9				3.3v to 3.7v	
<b>Ch2</b>	3 and 11				3.3v to 3.7v	
<b>Ch3</b>	5 and 13				3.3v to 3.7v	
<b>Ch4</b>	7 and 15				3.3v to 3.7v	

**10Hz**

	Coil Drive output pins	F1	F2	F3	Specification	Pass/Fail
<b>Ch1</b>	1 and 9				0.48 to 0.75v	
<b>Ch2</b>	3 and 11				0.48 to 0.75v	
<b>Ch3</b>	5 and 13				0.48 to 0.75v	
<b>Ch4</b>	7 and 15				0.48 to 0.75v	

**1 KHz**

	Coil Drive output pins	F1	F2	F3	Specification	Pass/Fail
<b>Ch1</b>	1 and 9				0.4v to 0.5v	
<b>Ch2</b>	3 and 11				0.4v to 0.5v	
<b>Ch3</b>	5 and 13				0.4v to 0.5v	
<b>Ch4</b>	7 and 15				0.4v to 0.5v	

Unit.....Serial No .....

Test Engineer .....

Date .....

## 10.2. Using the Dynamic Signal Analyser

With all filters switched in, measure the frequency response of each channel in turn between 0.1 Hz and 1KHz. If a fast turn around is required, limit the measurement to the frequency range to between 1 Hz and 1KHz. Measure the gain at the spot frequencies below and record them.

Connect the 39 ohm loads across each coil output to simulate the coils.

### Channel 1

Frequency	Gain (dB)	Expected Gain	Pass/Fail
0.1 Hz			
1Hz			
10Hz			
100Hz			
1KHz			

### Channel 2

Frequency	Gain (dB)	Expected Gain	Pass/Fail
0.1 Hz			
1Hz			
10Hz			
100Hz			
1KHz			

### Channel 3

Frequency	Gain (dB)	Expected Gain	Pass/Fail
0.1 Hz			
1Hz			
10Hz			
100Hz			
1KHz			

### Channel 4

Frequency	Gain (dB)	Expected Gain	Pass/Fail
0.1 Hz			
1Hz			
10Hz			
100Hz			
1KHz			

Unit.....Serial No .....  
 Test Engineer .....  
 Date .....

### 11. Noise Tests

Ensure the filter links W2, W3, W4 and W5 are present on each channel.

**Connect the filter test box, and switch in all filters.**

**Switch it out of Test Mode**

Use the HP 35670A Dynamic Signal Analyser.

Connect a shorting plug to the demand input to short all positive and negative demands together and to 0v. Connect 39 Ohm loads to the outputs.

Switch the filters in.

Use Stuart Aston's noise measurement set up, loaded from disc.

Measure the noise output from each channel in turn at the amplifier outputs. The Low Pass filter on the SR650 may be used to reduce mains interference, to prevent the Signal Analyser from overloading. Ideally the filter corner frequency should be set to 3 KHz, and readings should be made when the ambient noise is low. Set the amplifier gain to 1000, and check that the overload light is not on before each measurement.

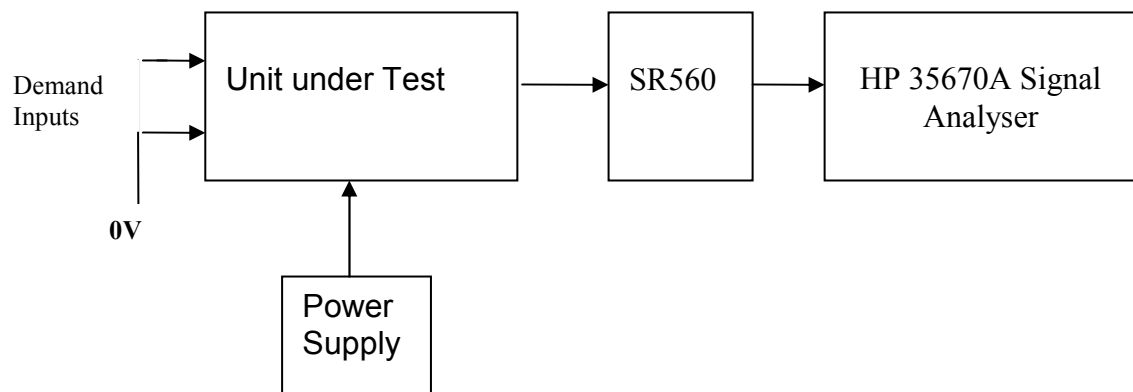

	Spec in dB V/ $\sqrt{\text{Hz}}$	Measured @ 10Hz	-60dB =
Ch1	-152.6		
Ch2	-152.6		
Ch3	-152.6		
Ch4	-152.6		

The specification at 10 Hz is a noise current of 3 pA per root Hz. The total load resistance is 7.8k. The permitted noise voltage from the amplifiers is therefore 23.4 nA/  $\sqrt{\text{Hz}}$  or -152.6 dB. The SR560 is set to a gain of 1000 (60dB) so 60dB needs to be subtracted from the reading.

Unit.....Serial No .....  
Test Engineer .....  
Date .....

### 12. Distortion

No filters. Increase input voltage to 10v peak,  $f = 1\text{KHz}$ . Dummy 39 Ohm loads. Check the differential voltage across each load for distortion with an analogue oscilloscope.

	Distortion Free?
Ch1	
Ch2	
Ch3	
Ch4	



Unit.....Serial No .....  
Test Engineer .....  
Date .....

### 13. Final Assembly Tests

1. Remove the lid of the box.
2. Unplug all external connections.
3. Check that the 9mm pillars are in place in the corners of the Monitor Board towards the centre of the box.
4. Check that all internal connectors are firmly mated.
5. Tighten the screw-locks holding all the external connectors.
6. Check that all the LEDs are nicely centred.
7. Check that links W3, W4 and W5 are in place.
8. Check that the boards are labelled with their Drawing Number, Issue Number, and serial number. Record below:

UoB box ID	
Driver board ID	
Driver board Drawing No/Issue No	
Driver board Serial Number	
Monitor board ID	
Monitor board Drawing No/Issue No	
Monitor board Serial Number	

9. Check the security of any modification wires.
10. Visually inspect.
11. Put the lid on and fasten all screws,  
Check all external screws for tightness.