

|      |      |       |                |
|------|------|-------|----------------|
| REV. | DATE | DCN # | DRAWING TREE # |
|      |      |       |                |

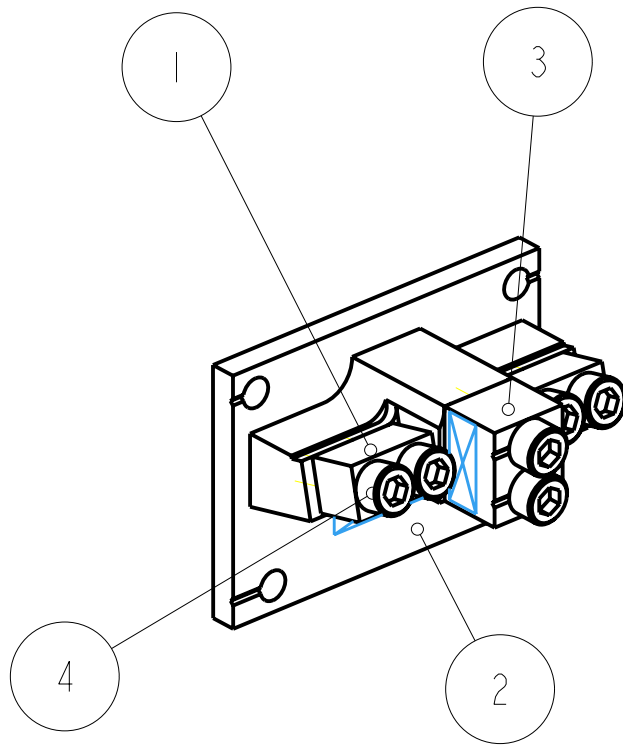

| 1    | 2   |       |       | D070433     | WIRE CLAMP JAW; BS MASSES                       | ST. STEEL: 304/316 |
|------|-----|-------|-------|-------------|---|--------------------|
| 2    | 1   |       |       | D080560     | MODIFIED D CLAMP BODY; BS ROUND MASS WIRE CLAMP | 304/316; ST. STEEL |
| 3    | 1   |       |       | D080561     | WIRE CLAMP JAW; BS MASSES                       | ST. STEEL: 304/316 |
| 4    | 6   |       |       |             | 8-32 UNC X 0.625" CAP HEAD; .                   |                    |
| ITEM | QTY | SPARE | TOTAL | PART NUMBER | DESCRIPTION                                     | MATERIALS          |

PARTS LIST

NOTES: (UNLESS OTHERWISE SPECIFIED)

1. REMOVE ALL SHARP EDGES, R.02 MIN.
2. DO NOT SCALE FROM DRAWING.
3. ALL MACHINING FLUIDS SHALL BE WATER SOLUBLE AND FREE OF SULFUR, CHLORINE AND SILICONE, SUCH AS CINCINNATI MILACRON'S CIMTECH 410 (STAINLESS STEEL)
4. SCRIBE, ENGRAVE OR STAMP DRAWING PARTNUMBER ON NOTED SURFACE OF PART AND A THREE DIGIT SERIAL NUMBER. SERIAL NUMBERS START AT 001 FOR THE FIRST PART AND PROCEED CONSECUTIVELY. USE .07" HIGH CHARACTERS. EXAMPLE: D020188- 001. A VIBRATORY TOOL MAY BE USED.

DIMENSIONS ARE IN mm [INCHES]  
TOLERANCES:

X.XX ± mm  
ANGULAR ± °

MATERIAL: -----  
AS DRW

FINISH: -----  
√μm [μin] Ra = AS DRW

|          |          |          |
|----------|----------|----------|
|          | NAME     | DATE     |
| DRAWN    | J O'DELL | SEP 08   |
| CHECKED  | AJB      | --/--/-- |
| APPROVED | ---      | --/--/-- |

 CALIFORNIA INSTITUTE OF TECHNOLOGY  
MASSACHUSETTS INSTITUTE OF TECHNOLOGY  
IGR, GLASGOW UNIVERSITY GEO 600 GROUP  
RUTHERFORD APPLETON LABORATORIES

|            |  |
|------------|--|
| SYSTEM     | <b>ADVANCED LIGO</b>                                       |
| SUB-SYSTEM | <b>SUS</b>   |
| NEXT ASSY  | <b>BS TRIPLE</b>   |
| PART NAME  | <b>MODIFIED D PENULTIMATE MASS CLAMP<br/>BS ROUND MASS</b> |

|           |   |              |
|-----------|---|--------------|
| SIZE      | DRG. NO.  | REV          |
| <b>A</b>  | <b>D080559</b>  | <b>F.</b>    |
| SCALE 1:1 | PROJECTION:  | SHEET 1 OF 1 |