

REV.	DATE	DCN #	DRAWING TREE #

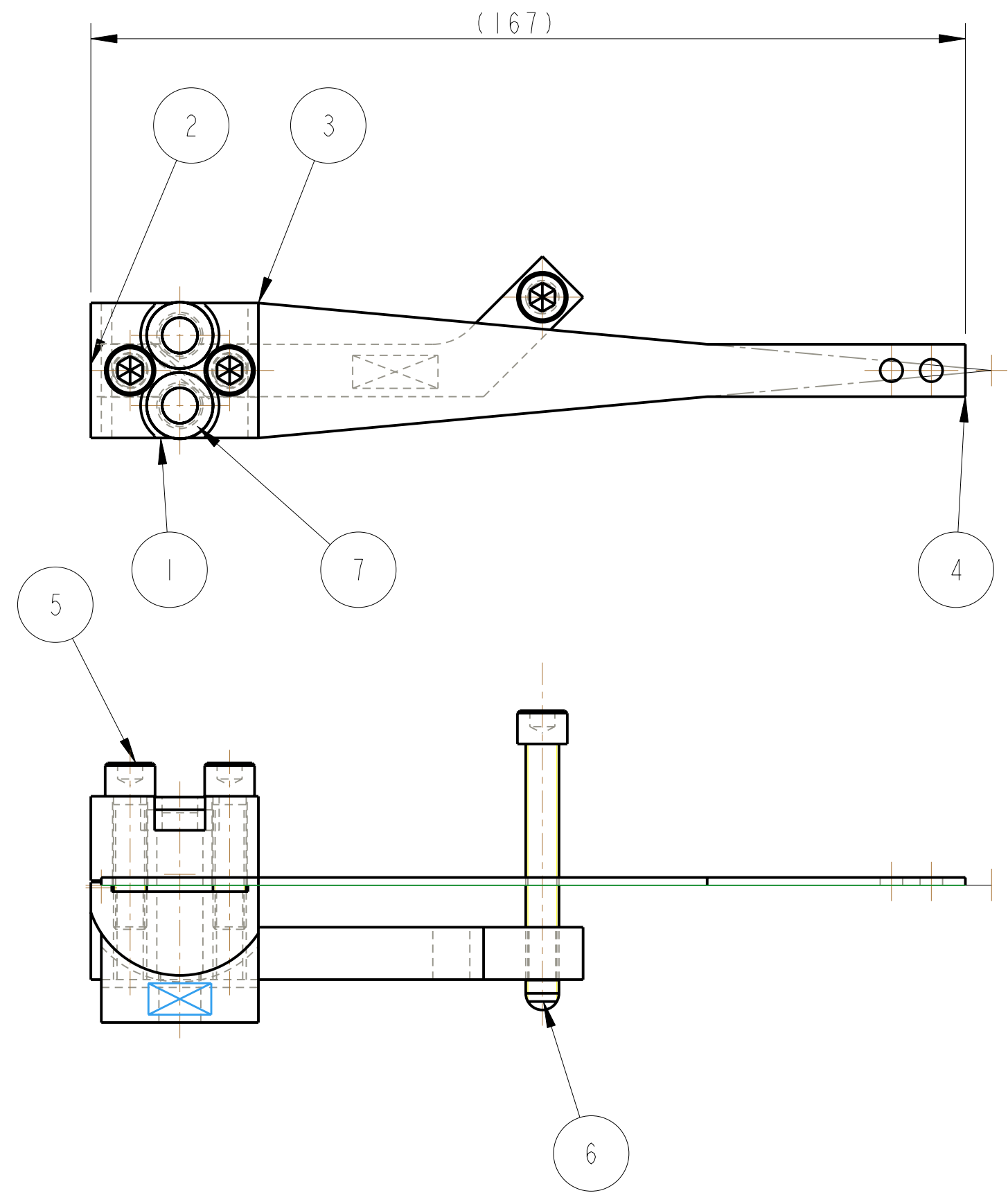

ITEM	QTY	SPARE	TOTAL	PART NUMBER	DESCRIPTION	MATERIALS
1	1			D070419	BLADE CLAMP BOTTON JAW; BS TOP MASS	AL ALLOY: 5083
2	1			D070420	BLADE CLAMP TOP JAW; BS TOP MASS	AL ALLOY: 5083 OR SIMILAR
3	1			D070421	BLADE TIP HEIGHT ADJ#2; BS TOP MASS	AL ALLOY: 5083 OR SIMILAR
4	1			D070417_FLAT	BOTTOM BLADE SPRINGS; BS TOP MASS	MARAGING STEEL 250: -----
5	2				1/4" 20 UNC X 1" CAP HEAD; .	
6	1				1/4" 20 UNC X 2" CAP HEAD, SPHERICAL TIP; .	
7	2				1/4 SPHERICAL WASHER; .	
PARTS LIST						

NOTES: (UNLESS OTHERWISE SPECIFIED)

- REMOVE ALL SHARP EDGES, R.02 MIN.
- DO NOT SCALE FROM DRAWING.
- ALL MACHINING FLUIDS SHALL BE WATER SOLUBLE AND FREE OF SULFUR, CHLORINE AND SILICONE, SUCH AS CINCINNATI MILACRON'S CIMTECH 410 (STAINLESS STEEL)
- SCRIBE, ENGRAVE OR STAMP DRAWING PARTNUMBER ON NOTED SURFACE OF PART AND A THREE DIGIT SERIAL NUMBER. SERIAL NUMBERS START AT 001 FOR THE FIRST PART AND PROCEED CONSECUTIVELY. USE .07" HIGH CHARACTERS. EXAMPLE: D020188- 001. A VIBRATORY TOOL MAY BE USED.

DIMENSIONS ARE IN mm [INCHES]  
TOLERANCES:  
X.XX ± mm °  
ANGULAR ± °

MATERIAL: -----

FINISH: CLEAN, GREASE FREE  
√μm [μin] Ra = 1.6

	NAME	DATE
DRAWN	NJS/FEL	17/12/07
CHECKED	J'OD	17/DEC/07
APPROVED	IW	17/DEC/07

**100** CALIFORNIA INSTITUTE OF TECHNOLOGY  
MASSACHUSETTS INSTITUTE OF TECHNOLOGY  
1GR, GLASGOW UNIVERSITY GEO 600 GROUP  
RUTHERFORD APPLETON LABORATORIES

SYSTEM **ADVANCED LIGO**

SUB-SYSTEM **SUS**

NEXT ASSY **BS TOP MASS**

PART NAME **BLADE CLAMP ASSY #2  
BS TOP MASS**

SIZE **B** DRG. NO. **D080043** REV **F.**

SCALE 1:1 PROJECTION: SHEET 1 OF 1