

A study for suppression of radiation pressure noise using ponderomotive squeezing in gravitational wave detectors

S Sakata¹, V Leonhardt², S Kawamura², K Numata³, O Miyakawa⁴, S Sato², A Nishizawa⁵, T Yamazaki², M Fukushima², A Furusawa⁶, and A Sugamoto¹

¹ Graduate School of Humanities and Sciences, Ochanomizu University, 2-1-1 Otsuka, Bunkyo-ku, Tokyo, 112-8610, Japan

² TAMA project, National Astronomical Observatory of Japan, 2-21-1 Osawa, Mitaka, Tokyo 181-8588, Japan

³ NASA Goddard Space Flight Center, CRESST, Code 663, Greenbelt, MD 20771, USA

⁴ LIGO project 18-34, California Institute of Technology, Pasadena, CA 91125, USA

⁵ Graduate School of Human and Environmental Studies, Kyoto University, Kyoto 606-8501, Japan

⁶ Department of Applied Physics, School of Engineering, The University of Tokyo, 7-3-1 Hongo, Bunkyo-ku, Tokyo 113-8656, Japan

E-mail: shihori.sakata@nao.ac.jp

Abstract.

We describe a conceptual design of experiment for observation of radiation pressure noise and suppression of it using ponderomotive squeezing. The radiation pressure noise is increased in a high finesse cavity with a small mass mirror. In our experiment a Fabry-Perot Michelson interferometer with a homodyne detection scheme will be built with Fabry-Perot cavities of a finesse of 10000 containing suspended mirrors of 23 mg. To observe the radiation pressure noise, the goal sensitivity is set to 1×10^{-17} [m/ $\sqrt{\text{Hz}}$] at 1 kHz. Then the radiation pressure noise is suppressed due to the ponderomotive squeezing by adjusting the homodyne phase. To achieve the sensitivity, the other noise sources such as thermal noise, seismic noise and laser frequency noise should be suppressed below 1×10^{-18} [m/ $\sqrt{\text{Hz}}$] at 1 kHz. The whole interferometer is suspended as a double pendulum on double-layer stacks. As a preliminary setup, a Fabry-Perot cavity of a finesse of 800 with a suspended mirror of 100 mg was locked. The current best sensitivity is 1×10^{-15} [m/ $\sqrt{\text{Hz}}$] at 1 kHz.

1. Introduction

The sensitivity of future gravitational-wave detectors will be limited by radiation pressure noise and shot noise in most frequency bands. To our knowledge, neither radiation pressure noise due to a vacuum fluctuation nor suppression of it using ponderomotive squeezing have been observed yet. When laser light and the vacuum fluctuation are injected into a cavity with suspended mirrors, the vacuum fluctuation is ponderomotively squeezed by the back action of the suspended mirror on the light [1].

2. Conceptual design

In this section, a conceptual design of an experiment for an observation of the radiation pressure noise and suppression of it using ponderomotive squeezing are described. This experiment will be a table-top experiment for the gravitational wave detectors in which the sensitivity could be limited by the radiation pressure noise in significant frequency bands for gravitational wave detections. In the experiment, a Fabry-Perot Michelson interferometer with a homodyne detection scheme will be built with high finesse Fabry-Perot cavities containing small suspended mirrors. The small suspended mirrors are constructed as the end mirrors of the cavities. The front mirrors are large fixed mirrors. The goal sensitivity to observe the radiation pressure noise is set to 1×10^{-17} [m/ $\sqrt{\text{Hz}}$] at 1 kHz. Then by adjusting the homodyne phase, the sensitivity limited by the radiation pressure noise is reduced by ponderomotive squeezing. The squeezing level is expected to be 3-4 dB. The other noise sources such as thermal noise, seismic noise, and laser frequency noise should be suppressed as much as possible. The experimental parameters are selected by taking into account the contributions of mirror thermal noise and suspension thermal noise which are especially fundamental noise sources in our experiment. Their contributions are shown in Figure 1 and the parameters are listed in Table 1. In the subsections below the radiation pressure noise and the other noise sources are described.

2.1. Radiation pressure noise and suppression of it by ponderomotive squeezing

Our experimental setup has Fabry-Perot cavities of a finesse of 10000 with suspended mirrors of 23 mg, since the radiation pressure noise is increased in high finesse cavities with small mass mirrors. The square root of the displacement noise spectral density due to the quantum fluctuation $D_{\text{QN}}(f)$ [1] is given by

$$D_{\text{QN}}(f) = \sqrt{\frac{h_{\text{SQL}}^2}{2} \left(\mathcal{K}_{\text{FPMI}}(f) + \frac{1}{\mathcal{K}_{\text{FPMI}}(f)} \right)}, \quad (1)$$

$$= 1 \times 10^{-17} \text{ [m}/\sqrt{\text{Hz}}] \left(\frac{23 \text{ mg}}{m_{\text{R}}} \right) \left(\frac{\mathcal{F}}{10000} \right) \sqrt{\frac{P}{120 \text{ mW}}}. \quad (2)$$

where $\mathcal{K}_{\text{FPMI}}(f)$ is

$$\mathcal{K}_{\text{FPMI}}(f) = \frac{4P\omega_0}{\sqrt{R_{\text{F}}} (1 - \sqrt{R_{\text{F}}})^2 m_{\text{R}}} \left(\frac{T_{\text{F}}\mathcal{F}}{(2\pi f)\pi c} \right)^2, \quad (3)$$

and $h_{\text{SQL}}(f)$ is written by

$$h_{\text{SQL}}(f) = \sqrt{\frac{4\hbar}{m_{\text{R}}(2\pi f)^2}}. \quad (4)$$

Here $h_{\text{SQL}}(f)$ is the square root of the standard quantum limit (SQL) spectral density. P is the laser power, ω_0 is the angular frequency, c is the speed of light, T_{F} is the power transmissivity of the front mirror, R_{F} is the power reflectivity of the front mirror, \mathcal{F} is the finesse, m_{R} is the reduced mass given by $m_{\text{R}} = m_{\text{F}} \times m_{\text{E}} / (m_{\text{F}} + m_{\text{E}})$, and f is the frequency.

The first term and the second one of equation (1) describe the radiation pressure noise and the shot noise, respectively. The noise is limited by the radiation pressure noise at 1 kHz with our selected parameters. Note that in equation (1) the effects of the losses are not included. The homodyne phase is fixed to the largest signal. $\mathcal{K}_{\text{FPMI}}(f)$ is derived for the experiment without any approximations other than the condition the reflectivity of the end mirror R_{E} is $R_{\text{E}} \simeq 1$.

The frequency of the cavity pole is higher than our target frequency, since the length of the cavity is short.

When the sensitivity is limited by the radiation pressure noise, the radiation pressure noise is suppressed due to the ponderomotive effect by adjusting the homodyne phase for the best signal to noise ratio. Then we obtain this displacement noise $D_{\text{PonSq}}(f)$

$$D_{\text{PonSq}}(f) = \sqrt{\frac{h_{\text{SQL}}^2}{2\mathcal{K}_{\text{FPMI}}(f)} \left(1 + (\mathcal{K}_{\text{FPMI}}(f_{\text{HD}}) - \mathcal{K}_{\text{FPMI}}(f))^2\right)}, \quad (5)$$

$$= 2 \times 10^{-18} [\text{m}/\sqrt{\text{Hz}}]. \quad (6)$$

Here f_{HD} is the frequency for the adjusted homodyne phase. The displacement noise could be $2 \times 10^{-18} [\text{m}/\sqrt{\text{Hz}}]$, if any losses from the cavities, the optics, and the detectors are not existed. In the experiment, as the result of taking into account the actual losses, it is expected the radiation pressure noise is suppressed by ponderomotive squeezing of 3-4 dB.

2.2. Mirror thermal noise and suspension thermal noise

Thermal noise of the mirrors is given by summation of substrate and coating Brownian noise [2, 3, 4, 5], and substrate and coating thermoelastic noise [6, 7, 8]. The thermoelastic noise is not described here, since it is found that in case of using fused silica the noise sources become sufficiently smaller than the Brownian noise. The square root of the spectral density due to the thermal noise from the substrate and the coating $D_{\text{BrownTN}}(f)$ is given by

$$D_{\text{BrownTN}}(f) = \sqrt{\frac{4k_{\text{B}}T}{2\pi f} \frac{1 - \sigma^2}{\sqrt{\pi}E_0w} \phi_{\text{sub}} \left(1 + \frac{\alpha_{\text{coat}}}{\sqrt{\pi}w} \frac{1 - 2\sigma}{1 - \sigma} \frac{\phi_{\text{coat}}}{\phi_{\text{sub}}} \left(\frac{E_{\text{coat}}}{E_0} + \frac{E_0}{E_{\text{coat}}}\right)\right)}, \quad (7)$$

$$= 2 \times 10^{-18} [\text{m}/\sqrt{\text{Hz}}] \left(\sqrt{\frac{\phi_{\text{sub}}}{10^{-5}}} \sqrt{\frac{342 \mu\text{m}}{w}} + \sqrt{\frac{\phi_{\text{coat}}}{4 \times 10^{-4}}} \left(\frac{342 \mu\text{m}}{w}\right) \right). \quad (8)$$

Here k_{B} is the Boltzmann constant, σ is the Poisson ratio of the substrate, E_0 is the substrate Young 's modulus, E_{coat} is the coating Young 's modulus, ϕ_{sub} is the loss angle of the substrate,

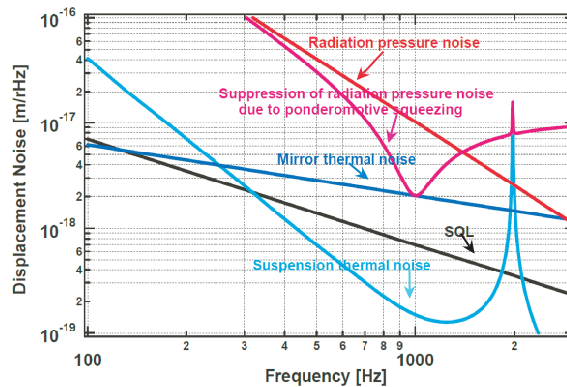

Figure 1. Noise budget for the experiment; The radiation pressure noise level is set to $1 \times 10^{-17} [\text{m}/\sqrt{\text{Hz}}]$. The suppressed radiation pressure noise level using the ponderomotive squeezing could be $2 \times 10^{-18} [\text{m}/\sqrt{\text{Hz}}]$ in case of no losses. The contributions from the other fundamental noise sources were designed to be smaller than this level.

ϕ_{coat} is the loss angle of the coating, w is the beam radius on the substrate, and α_{coat} is the thickness of the coating.

In the experiment, the mirror is suspended by a silica fiber, since the suspension thermal noise should be reduced substantially against the radiation pressure noise level. As a consequence of considering the suspension thermal noise level and the loss angle of the silica fiber, its thickness of $10\ \mu\text{m}$ is chosen. The loss angle of the silica fiber $\phi_{\text{fib}}(t_{\text{fib}})$ is approximately written by [10]

$$\phi_{\text{fib}}(t_{\text{fib}}) = 3.5 \times 10^{-8} \left(1 + \frac{1.336 \times 10^{-3} \text{ m}}{t_{\text{fib}}} \right). \quad (9)$$

Generally when the suspension thermal noise in gravitational wave detectors is calculated, it is assumed the potential energy of the suspension is dominated by its gravitational energy. However in our case the calculation of the suspension thermal noise should take into account the effects due to both of its gravitational energy and elastic energy. The square root of the spectral density of the suspension thermal noise $D_{\text{susTN}}(f)$ is given by

$$D_{\text{susTN}}(f) = \sqrt{\frac{4k_{\text{B}}T}{(2\pi f)^2} \text{Re} \left[\left(\frac{K(f) - m(2\pi f)^2}{i2\pi f} \right)^{-1} \right]}, \quad (10)$$

$$= 1.5 \times 10^{-19} [\text{m}/\sqrt{\text{Hz}}]. \quad (11)$$

Here the specific equations of the effective spring constant $K(f)$ is not described here [9].

2.3. Non-fundamental noise

To achieve the goal sensitivity, the other noise levels such as seismic noise and laser frequency noise should be suppressed below $1 \times 10^{-18} [\text{m}/\sqrt{\text{Hz}}]$ at 1 kHz. The seismic noise which is $1 \times 10^{-13} [\text{m}/\sqrt{\text{Hz}}]$ at 1 kHz in our institute has to be suppressed by more than 100 dB. The laser frequency noise should be suppressed by more than 60 dB, since it is supposed that its free-running noise level is $1 \times 10^{-15} [\text{m}/\sqrt{\text{Hz}}]$ at 1 kHz.

Table 1. Experimental parameters.

Parameter	Symbol	Value	Parameter	Symbol	Value
Laser power	P_0	200 mW	Beam waist on end mirror	w_{E}	$342\ \mu\text{m}$
Injected laser power	P	120 mW	Substrate loss angle	ϕ_{sub}	10^{-5}
Finesse	\mathcal{F}	10000	Coating loss angle	ϕ_{coat}	4×10^{-4}
End mirror mass	m_{E}	23 mg	Length of silica fiber	l_{fib}	1 cm
Diameter of end mirror	d_{E}	3 mm	Thickness of silica fiber	t_{fib}	$10\ \mu\text{m}$
Thickness of end mirror	t_{E}	1.5 mm	Temperature	T	300 K
Front mirror mass	m_{F}	14 g	Boltzmann constant	k_{B}	$1.38 \times 10^{-23} \text{ JK}^{-1}$
Reflectivity of end mirror	R_{E}	99.999 %	substrate Poisson ratio	σ	0.17
Reflectivity of front mirror	R_{F}	99.94 %	substrate Young 's modulus	E_0	$7.24 \times 10^{10} \text{ Pa}$
Loss of front mirror	L_{F}	30 ppm	coating Young 's modulus	E_{coat}	$1.4 \times 10^{11} \text{ Pa}$

3. Experimental setup

In this section we describe the experimental setup for the suppression of the radiation pressure noise due to the ponderomotive squeezing. The Fabry-Perot Michelson interferometer with a homodyne detection scheme is suspended by a double pendulum with an eddy-current damping system on double-layer stacks. The mirrors of 23 mg are suspended by double pendulums. The other optical components are fixed. In the subsections below we describe the measured isolation ratios of the seismic isolation systems and the optical configuration.

3.1. Seismic isolation systems

Isolation ratios of the double suspension and the double-layer stacks were measured using an excitation machine to shake a ground in the horizontal and vertical directions. The taken isolation ratios are shown in Figure 2 and Figure 3, respectively. The isolation ratios around 1 kHz seem to be worse, since the measurement above 100 Hz is limited by the sensor noise.

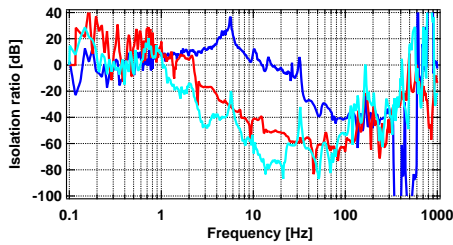

Figure 2. Red line, blue line, and cyan line are the isolation ratio of the double suspension from horizontal to horizontal, from vertical to vertical, and from vertical to horizontal, respectively.

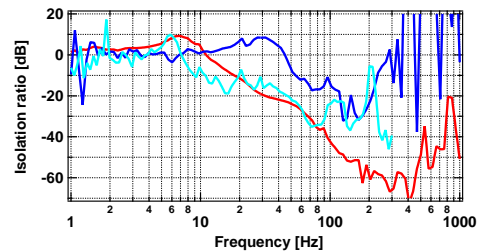

Figure 3. Red line, blue line, and cyan line are isolation ratio of the double-layer stack from horizontal to horizontal, from vertical to vertical, and from vertical to horizontal, respectively.

3.2. Optical configuration

The optical configuration is shown in Figure 4.

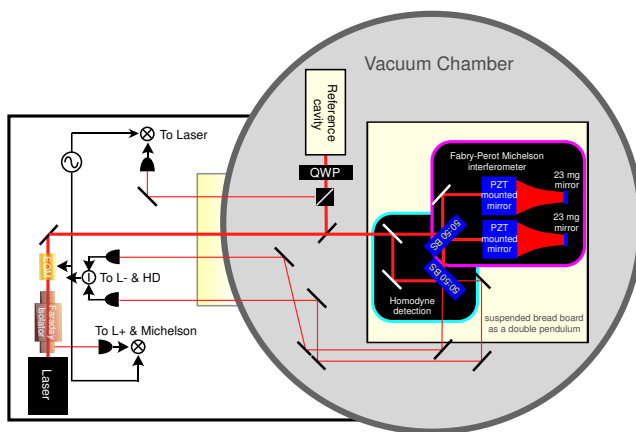

Figure 4. Schematic of the interferometer for the suppression of the radiation pressure noise due to the ponderomotive squeezing. The suspended mirrors of 23 mg are constructed as end mirrors of the cavities. The suspension has a middle mass of 23 mg for the eddy-current damping. The cavities with the lengths of 10 cm are actuated by PZT mounted on the large fixed front mirror. The reference cavity is installed for the laser frequency noise.

4. A Fabry-Perot cavity locked with a suspended mirror of 100 mg

As it is described above, we have to operate Fabry-Perot cavities of a finesse of 10000 with 23 mg mirrors suspended by silica fibers of $10 \mu\text{m}$. However it was not evident a Fabry-Perot cavity with the suspended tiny mirror could be operated. Therefore as a preliminary experiment, we did lock a Fabry-Perot cavity of the finesse of 800 with a mirror of 100 mg suspended by a tungsten

wire of $10\ \mu\text{m}$ with the seismic isolation systems in place. Pictures of the suspension are shown in Figure 5. The suspension is a double pendulum with an eddy-current damping system. It has a damped middle mass of 100 mg. The cavity with the length of 10 cm is actuated by PZT mounted on the large fixed front mirror. The current best sensitivity is $1 \times 10^{-15}\ \text{m}/\sqrt{\text{Hz}}$ at 1 kHz as shown in Figure 6. The sensitivity above 100 Hz seems to be limited by laser frequency noise. To achieve the sensitivity goal, a noise reduction of 60 dB for the laser frequency noise is needed. Therefore a reference cavity with a finesse of 50000 will be installed, and common mode noise rejection ratio (CMRR) of 1/100 would be achieved.

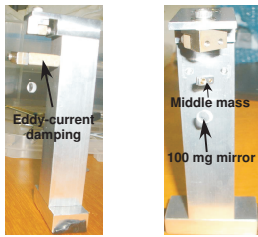

Figure 5. Pictures of the suspension with the mirror of 100 mg.

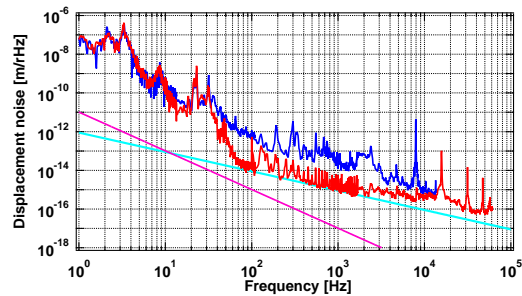

Figure 6. Displacement noise of the Fabry-Perot cavity with the suspended mirror of 100 mg. Blue line and red line are its noise in air and in vacuum, respectively. Cyan line is typical theoretical free-running laser frequency noise line. Pink line is the goal sensitivity for the observation of the radiation pressure noise.

5. Summary

We described a conceptual design of an experiment for observation of radiation pressure noise and suppression of it using ponderomotive squeezing. The goal sensitivity to observe the radiation pressure noise is set to $1 \times 10^{-17}\ \text{[m}/\sqrt{\text{Hz}}]$ at 1 kHz. Then the radiation pressure noise will be suppressed due to the ponderomotive squeezing of 3-4 dB by adjusting the homodyne phase to the best signal to noise ratio. As a preliminary setup, we did lock a Fabry-Perot cavity of a finesse of 800 with a suspended mirror of 100 mg. The current best sensitivity is $1 \times 10^{-15}\ \text{[m}/\sqrt{\text{Hz}}]$ at 1 kHz. In the future, the current suspension systems with mirrors of 100 mg will be changed to mirrors of 23 mg suspended by silica fiber of $10\ \mu\text{m}$ with a length of 1 cm.

Acknowledgments

The authors would like to thank engineers of the machine shop at National Astronomical Observatory of Japan for making special components of the suspension with the 100 mg mirror and the seismic isolation systems. The research is supported in part by the United States National Science Foundation grant PHY-0107417 for the construction and operation of the LIGO Laboratory and the Science.

References

- [1] Kimble H J, Levin Y, Matsko B A, Thorne S K and Vyatchanin P S 2002 *Phys. Rev. D* **65** 022002
- [2] Levin Y 1998 *Phys. Rev. D* **57** 659
- [3] Bondu F, Hello P and Vinet J 1998 *Phys. Lett. A* **246** 227
- [4] Nakagawa N, Gretarsson M A, Gustafson K E and Fejer M M 2002 *Phys. Rev. D* **65** 102001F
- [5] Harry M G et al. 2002 *Class. Quantum. Grav.* **19** 897
- [6] Braginsky B V, Gorodetsky L M and Vyatchanin P S 1999 *Phys. Lett. A* **264** 1
- [7] Cerdonio M, Conti L, Heidmann A and Pinard M 2001 *Phys. Rev. D* **63** 082003
- [8] Fejer M M, Rowan S, Cagnoli G, Crooks M R D, Gretarsson A, Harry M G, Hough J, Penn D S, Sneddon H P and Vyatchanin P S 2004 *Phys. Rev. D* **70** 082003
- [9] González I G and Saulson R P 1994 *J. Acoust. Soc. Am.* **96** 207
- [10] Bilenko A I, Braginsky B V and Lourie L S 2004 *Class. Quantum. Grav.* **21** S1231