

NOTES CONTINUED:

⑤ SCRIBE, OR ENGRAVE (NO INKS OR DYES) DRAWING PART NUMBER AND REVISION ON NOTED SURFACE FOLLOWED ON THE NEXT LINE BY A THREE DIGIT SERIAL NUMBER. SERIAL NUMBERS START AT 001 FOR THE FIRST ARTICLE AND PROCEED CONSECUTIVELY. USE .07" MINIMUM HIGH CHARACTERS.
 EXAMPLE: DXXXXXX-VY, S/N 001.
 A VIBRATORY TOOL MAY BE USED.

6. MACHINE ALL SURFACES

REV.	DATE	DCN #	DRAWING TREE #
v1	22 OCT 2009	E0900345-v1	-
-	-	-	-
-	-	-	-

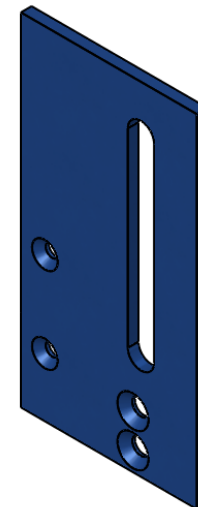
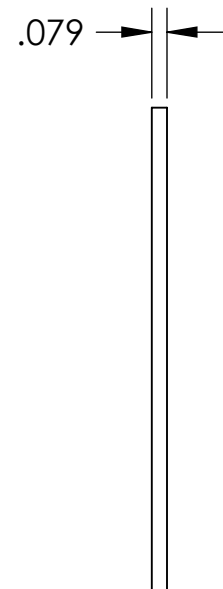
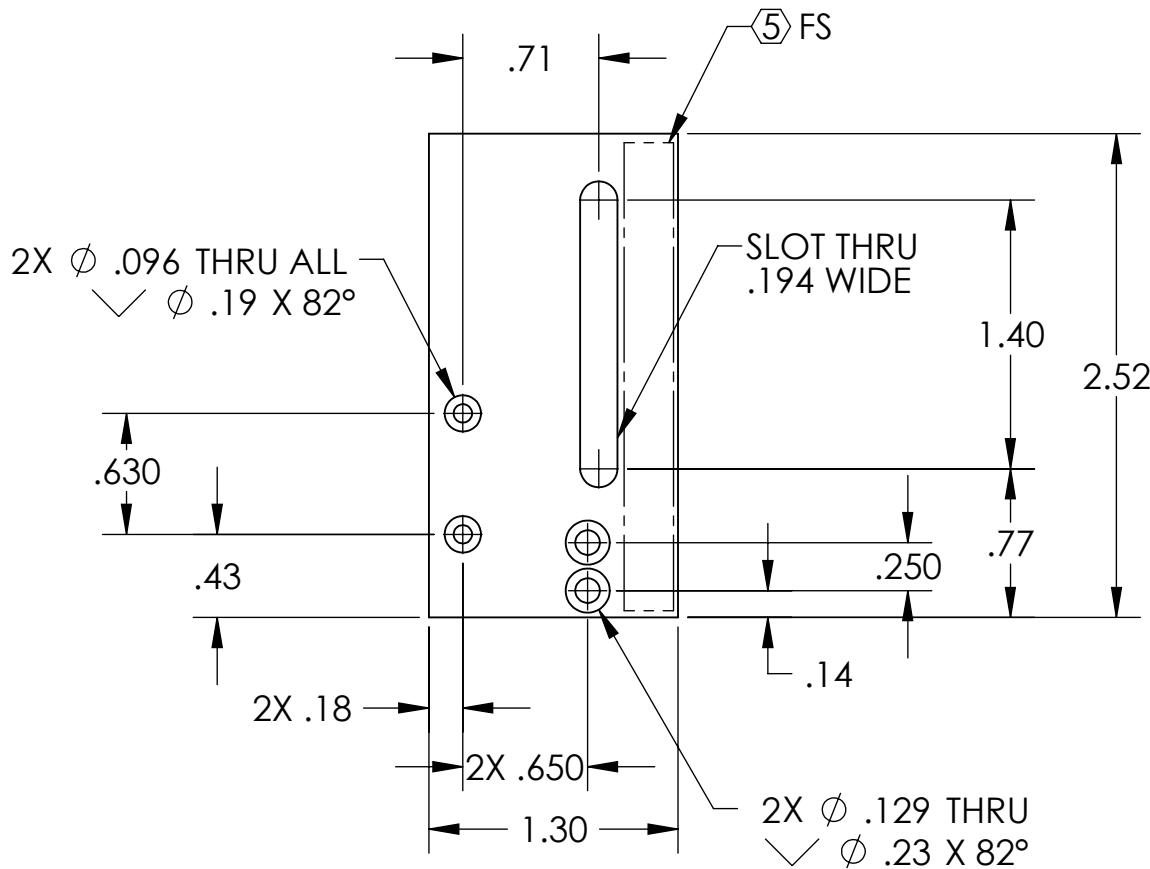

NOTES AND TOLERANCES: (UNLESS OTHERWISE SPECIFIED)

DIMENSIONS ARE IN INCHES

TOLERANCES:
 .XX ± .01
 .XXX ± .005

ANGULAR ± 1.0°

1. INTERPRET DRAWING PER ASME Y14.5-1994.
2. REMOVE ALL SHARP EDGES, R.02 MIN.
3. DO NOT SCALE FROM DRAWING.
4. ALL MACHINING FLUIDS MUST BE FULLY SYNTHETIC, FULLY WATER SOLUBLE AND FREE OF SULFUR, SILICONE, AND CHLORINE.

MATERIAL: 6061-T6 ALU, .100 SHEET STK MIN
 FINISH: 32 µin. R_a

LIGO CALIFORNIA INSTITUTE OF TECHNOLOGY
 MASSACHUSETTS INSTITUTE OF TECHNOLOGY

SYSTEM: ADVANCED LIGO
 SUB-SYSTEM: AOS
 NEXT ASSY: D0902447

PART NAME: LASTI TCS RING HEATER BACK PLATE LH

DESIGNER: KMAILAND	16 JUN 2009	SIZE: A	DWG. NO.: D0902449	REV.: v1
DRAFTER: C.CONLEY	09 OCT 2009			
CHECKER:				
APPROVAL:		SCALE: NONE PROJECTION:		

SHEET 1 OF 1