

NOTES: (UNLESS OTHERWISE SPECIFIED)

- REMOVE ALL SHARP EDGES.
R0.2 MIN.
- DO NOT SCALE FROM DRAWING.
- ALL MACHINING FLUIDS SHALL BE
WATER SOLUBLE AND FREE OF
SULFUR, CHLORINE AND SILICONE.
SUCH AS CINCINNATI MILACRON'S
CMTTECH 410 (STAINLESS STEEL)
- SCRIBE, ENGRAVE OR STAMP DRAWING
PART NUMBER ON NOTED SURFACE OF
PART AND A THREE DIGIT SERIAL
NUMBER. SERIAL NUMBERS START
AT 001 FOR THE FIRST PART AND
PROCEED CONSECUTIVELY.
USE 07" HIGH CHARACTERS.
EXAMPLE: D080100-001 - A VIBRATOR
TOOL MAY BE USED.

DIMENSIONS ARE IN mm (INCHES)
TOLERANCES:
X XX ± 0.2
ANGULAR ±0.25 °

MATERIAL: AL ALLOY
6061 OR SIMILAR

FINISH: CLEAN, GREASE FREE
√Ra (µm) Ra = 1.6

NAME	DATE	SIZE
DRAWN	REVISED	DEC 2007
CHECKED	J'00	JAN 2008
APPROVED	TW	JAN 2008

CALIFORNIA INSTITUTE OF TECHNOLOGY
MASSACHUSETTS INSTITUTE OF TECHNOLOGY
OPR. GLASGOW UNIVERSITY DES GRP GROUP
RUTHERFORD APPLTON LABORATORIES

SYSTEM: **ADVANCED LIGO**

SUB-SYSTEM: **SUS**

NEXT ASSY: **D080005**

PART NAME: **BS LOWER STRUCTURE**

BS LS BOTTOM HALF

DRG. NO.: **D080006**

SCALE: 1:1 PROJECTION: **F**

SHEET 1 OF 2

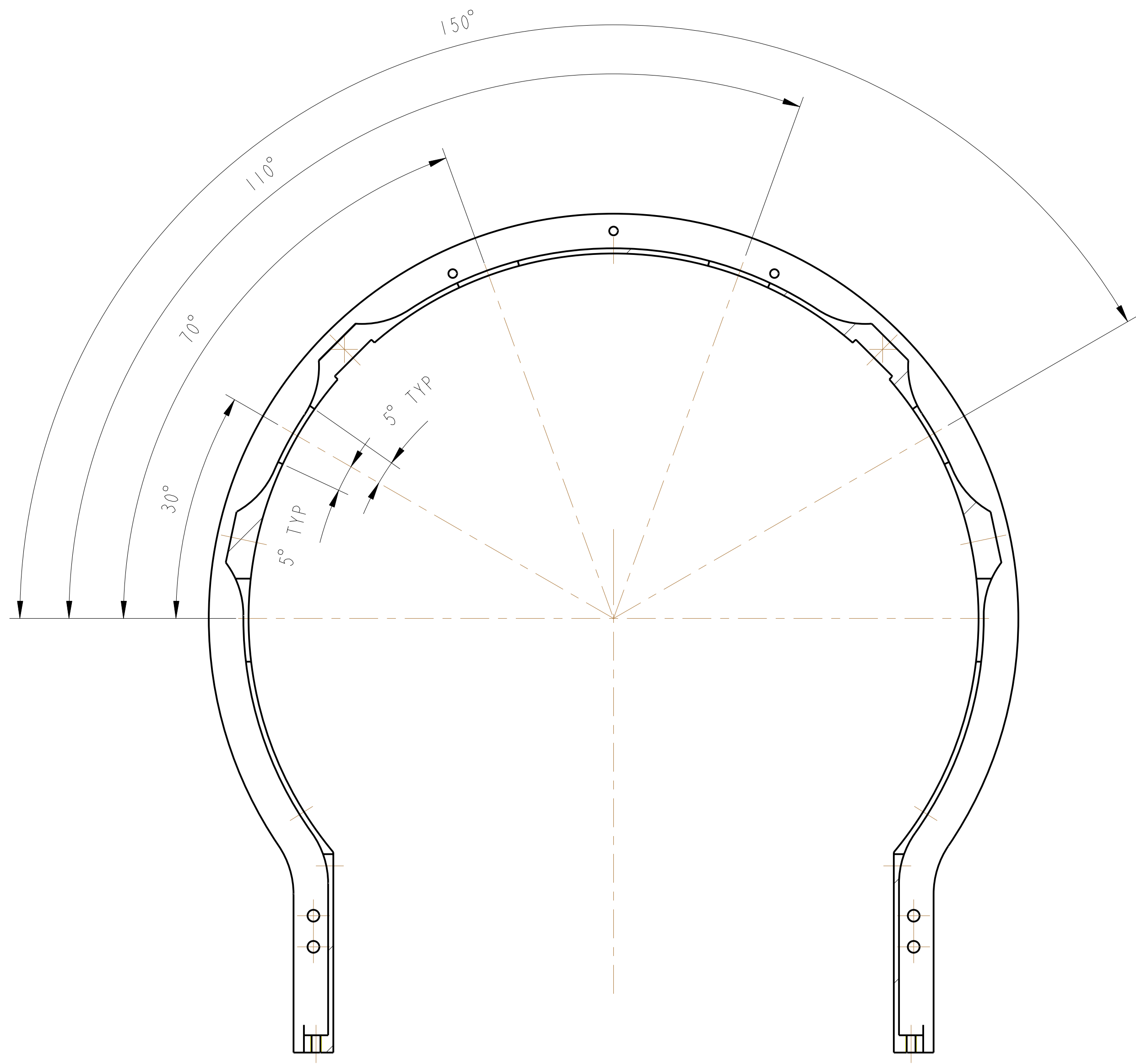
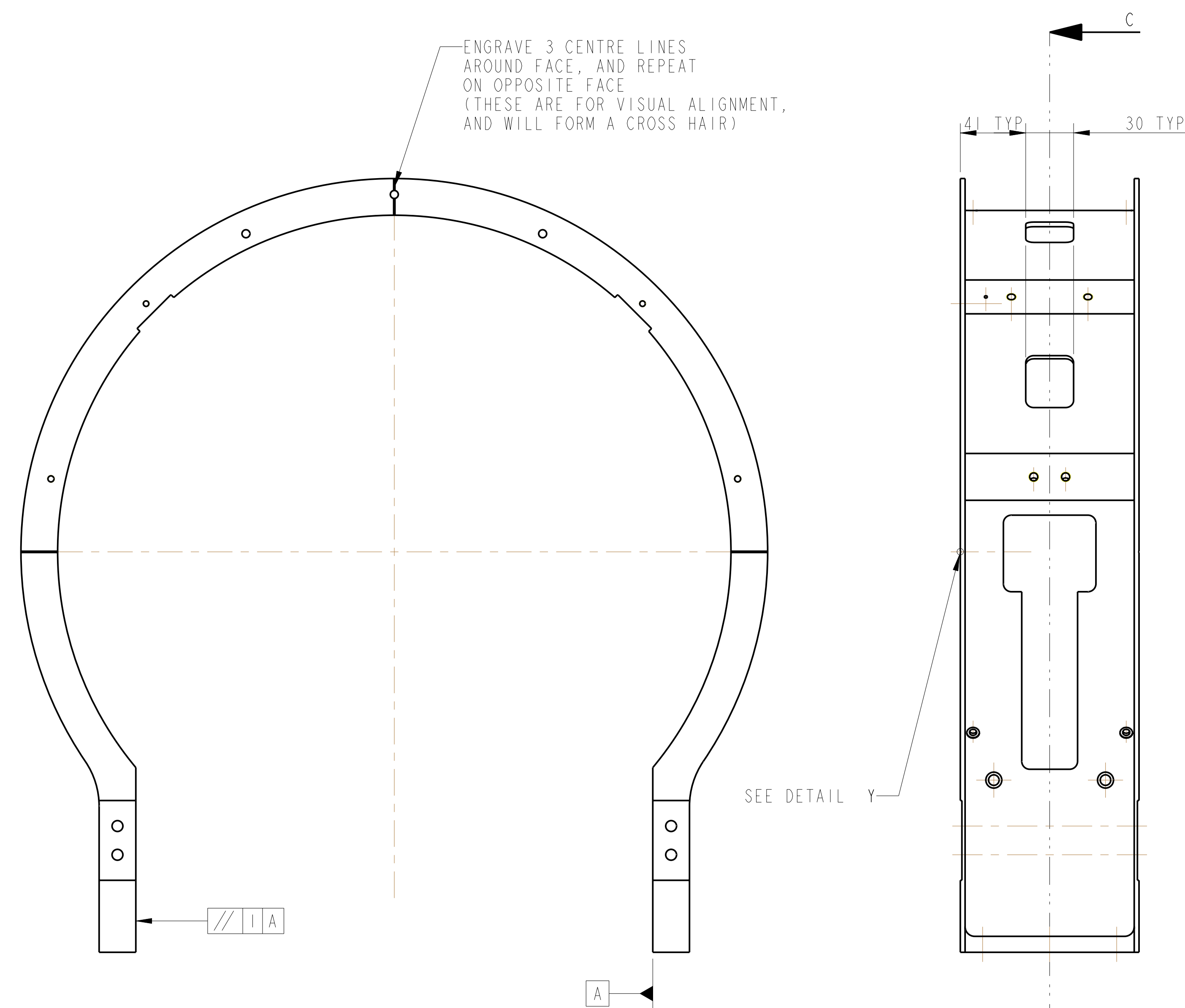

SECTION C-C

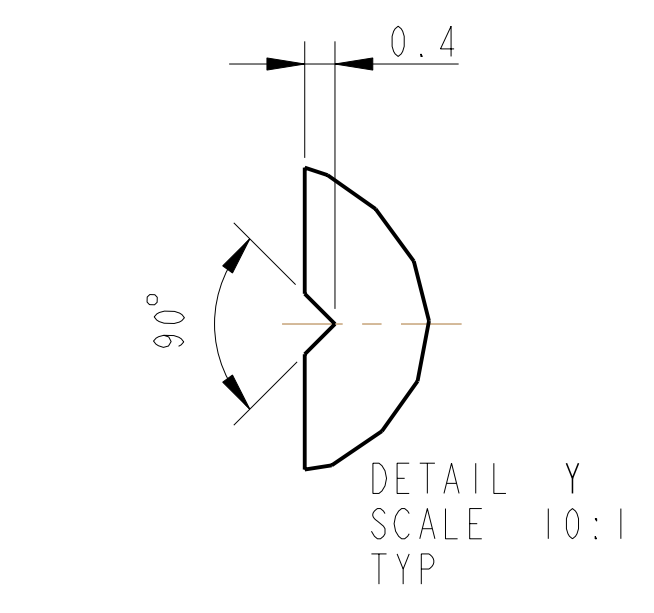

NOTES: (UNLESS OTHERWISE SPECIFIED)

- REMOVE ALL SHARP EDGES. R.02 MIN.
- DO NOT SCALE FROM DRAWING.
- ALL MACHINING FLUIDS SHALL BE WATER SOLUBLE AND FREE OF SULFUR, CHLORINE AND SILICONE. SUCH AS CINCINNATI MILACRON'S CIMTECH 410 (STAINLESS STEEL).
- SCRIBE, ENGRAVE OR STAMP DRAWING PART NUMBER ON NOTED SURFACE OF PART AND A THREE DIGIT SERIAL NUMBER. SERIAL NUMBERS START AT 001 FOR THE FIRST PART AND PROCEED CONSECUTIVELY. USE 07" HIGH CHARACTERS. EXAMPLE: D080006-001 - A VIBRATORY TOOL MAY BE USED.

DIMENSIONS ARE IN mm (INCHES) TOLERANCES:

X.XX ± .13 ANGLULAR ±0.25 °

MATERIAL: AL ALLOY 6061 OR SIMILAR

FINISH: CLEAN, GREASE FREE \sqrt{Ra} (µm) Ra = 1.6

NAME	DATE
DRAWN	30/09/08
REVISED	
CHECKED	J'00 JAN 2008
APPROVED	1W JAN 2008

CALIFORNIA INSTITUTE OF TECHNOLOGY
 MASSACHUSETTS INSTITUTE OF TECHNOLOGY
 GLASGOW UNIVERSITY GEC ROX GROUP
 RUTHERFORD APPLINGTON LABORATORIES

SYSTEM: **ADVANCED LIGO**

SUB-SYSTEM: **SUS**

NEXT ASSY: **THIS**

PART NAME: **BS LOWER STRUCTURE**

DRG. NO.: **D080006**

SCALE: 1:21 PROJECTION: **F**

SHEET 2 OF 2