

REV.	DATE	DCN #	DRAWING TREE #
A	15/OCT/06	E060240	

	A	VARIANT
D060359-012_5	11.9	I
D060359-025_0	15.53	II
D060359-037_5	18.46	III
D060359-050_0	20.98	IV
D060359-062_5	23.23	V
D060359-075_0	25.28	VI
D060359-087_5	27.18	VII
D060359-100_0	28.95	VIII
D060359-200_0	40.42	XVI

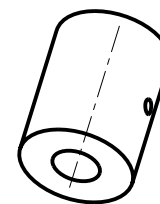

3D VIEW

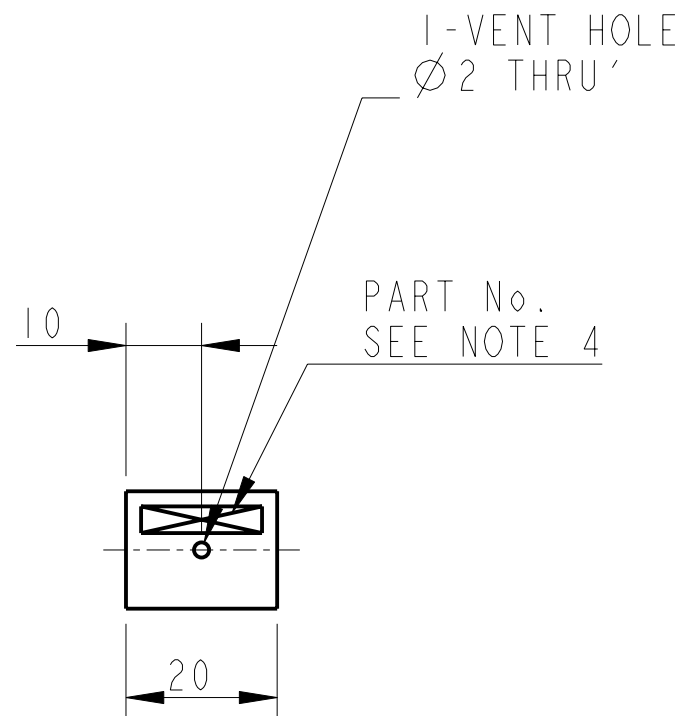
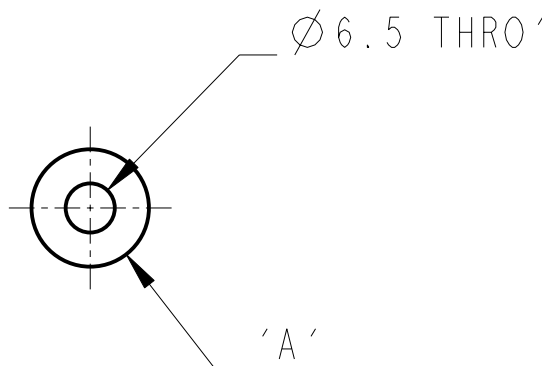

ADDITIONAL NOTES:
5. PART NUMBERS TO BE OMMITED

NOTES: (UNLESS OTHERWISE SPECIFIED)		CALIFORNIA INSTITUTE OF TECHNOLOGY MASSACHUSETTS INSTITUTE OF TECHNOLOGY IGR, GLASGOW UNIVERSITY GEO 600 GROUP RUTHERFORD APPLETON LABORATORIES												
1. REMOVE ALL SHARP EDGES, R.02 MIN. 2. DO NOT SCALE FROM DRAWING. 3. ALL MACHINING FLUIDS SHALL BE WATER SOLUBLE AND FREE OF SULFUR, CHLORINE AND SILICONE, SUCH AS CINCINNATI MILACRON'S CIMTECH 410 (STAINLESS STEEL) 4. SCRIBE, ENGRAVE OR STAMP DRAWING PARTNUMBER ON NOTED SURFACE OF PART AND A THREE DIGIT SERIAL NUMBER. SERIAL NUMBERS START AT 001 FOR THE FIRST PART AND PROCEED CONSECUTIVELY. USE .07" HIGH CHARACTERS. EXAMPLE: D020188- 001. A VIBRATORY TOOL MAY BE USED.	DIMENSIONS ARE IN mm [INCHES] TOLERANCES: X.XX ±0.2 mm ANGULAR ±0.25 °		SYSTEM ADVANCED LIGO											
	MATERIAL: ST. STEEL 316		SUB-SYSTEM SUS											
	FINISH: CLEAN, GREASE FREE √μm [μin] Ra = 1.6		NEXT ASSY QUAD N-PTYPE											
	<table border="1"> <thead> <tr> <th></th> <th>NAME</th> <th>DATE</th> </tr> </thead> <tbody> <tr> <td>DRAWN</td> <td>J O'DELL</td> <td>11/NOV/05</td> </tr> <tr> <td>CHECKED</td> <td>IW</td> <td>15/SEPT/06</td> </tr> <tr> <td>APPROVED</td> <td>IW</td> <td>15/SEPT/06</td> </tr> </tbody> </table>			NAME	DATE	DRAWN	J O'DELL	11/NOV/05	CHECKED	IW	15/SEPT/06	APPROVED	IW	15/SEPT/06
	NAME	DATE												
DRAWN	J O'DELL	11/NOV/05												
CHECKED	IW	15/SEPT/06												
APPROVED	IW	15/SEPT/06												
SIZE A DRG. NO. D060359		SCALE 1:1 PROJECTION: SHEET 1 OF 1												