

- REFER TO G1000125 FOR ISI NAMING AND ORIENTATION CONVENTION.
- REFER TO T1100292 FOR VIEWPORT DEFINITION.
- DIMENSION WRT TO LOCAL BUILDING CS. REFER TO E1200625 FOR LOCAL COORDINATES OF SUPPORT TUBE ENDS.

REV.	DATE	DCN #	DRAWING TREE #
v3	19 OCT 2012		
v10	22 FEB 2018	E1700274-x0	
v11	17 JUL 2018	E1800214-x0	

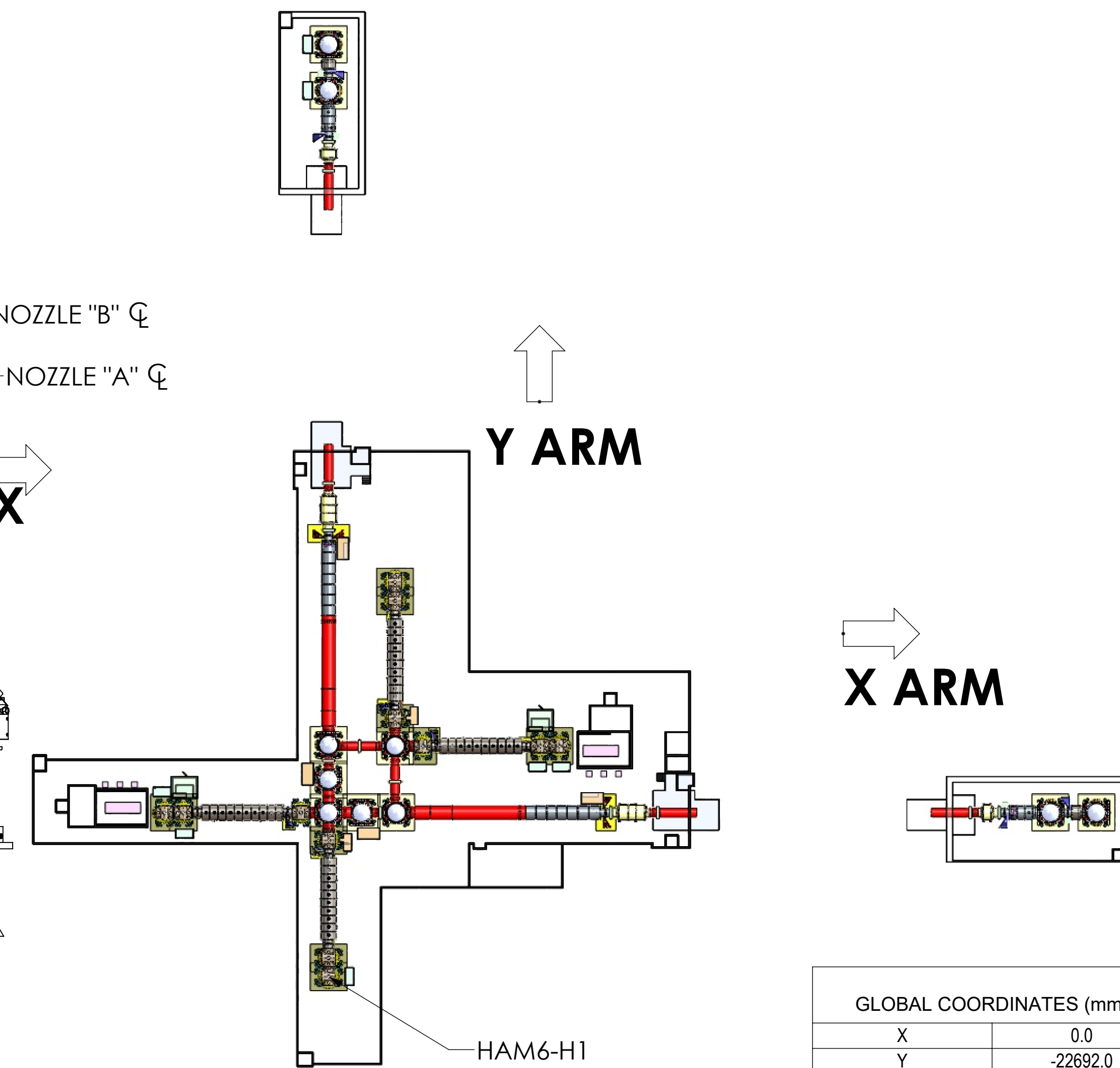
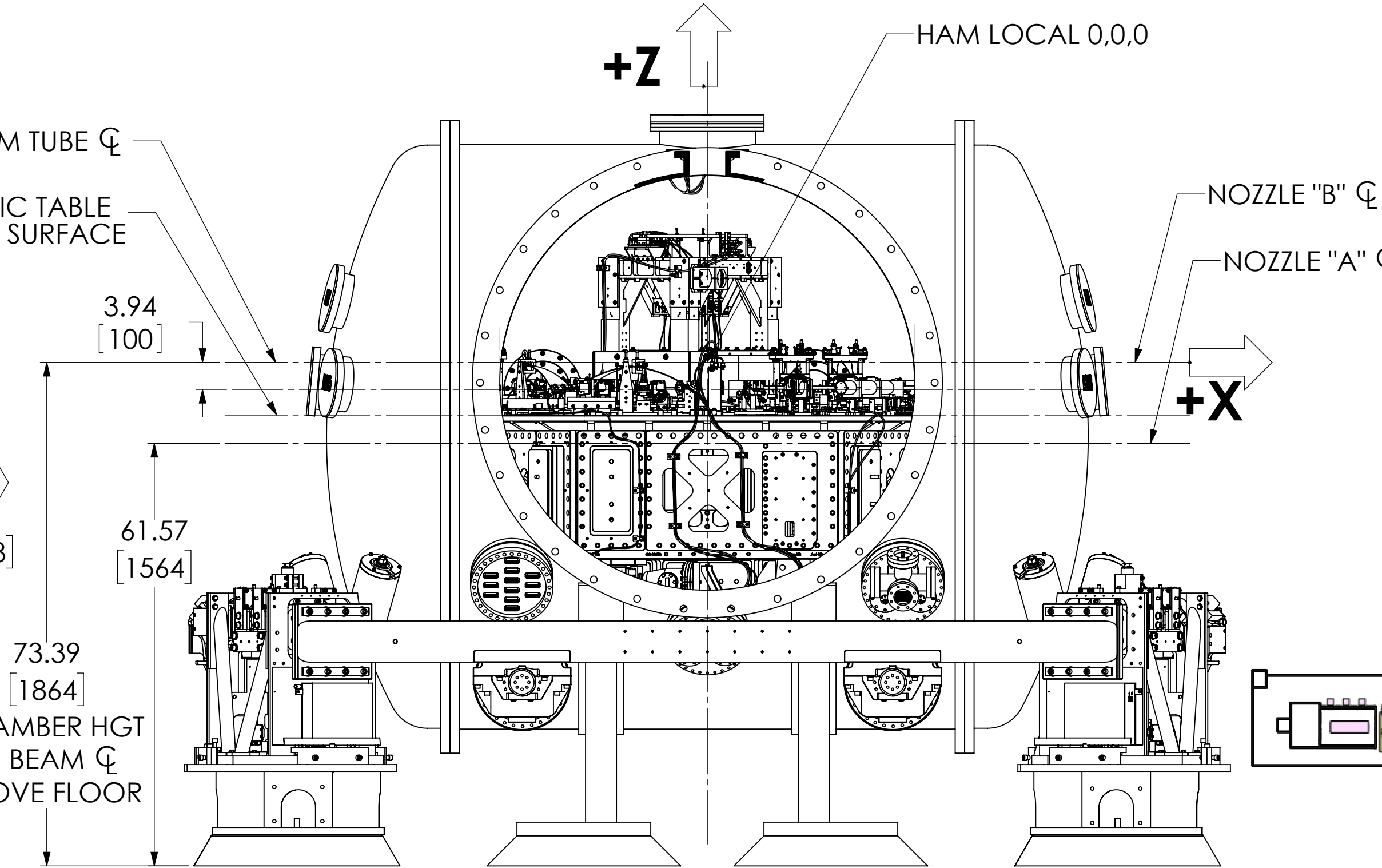
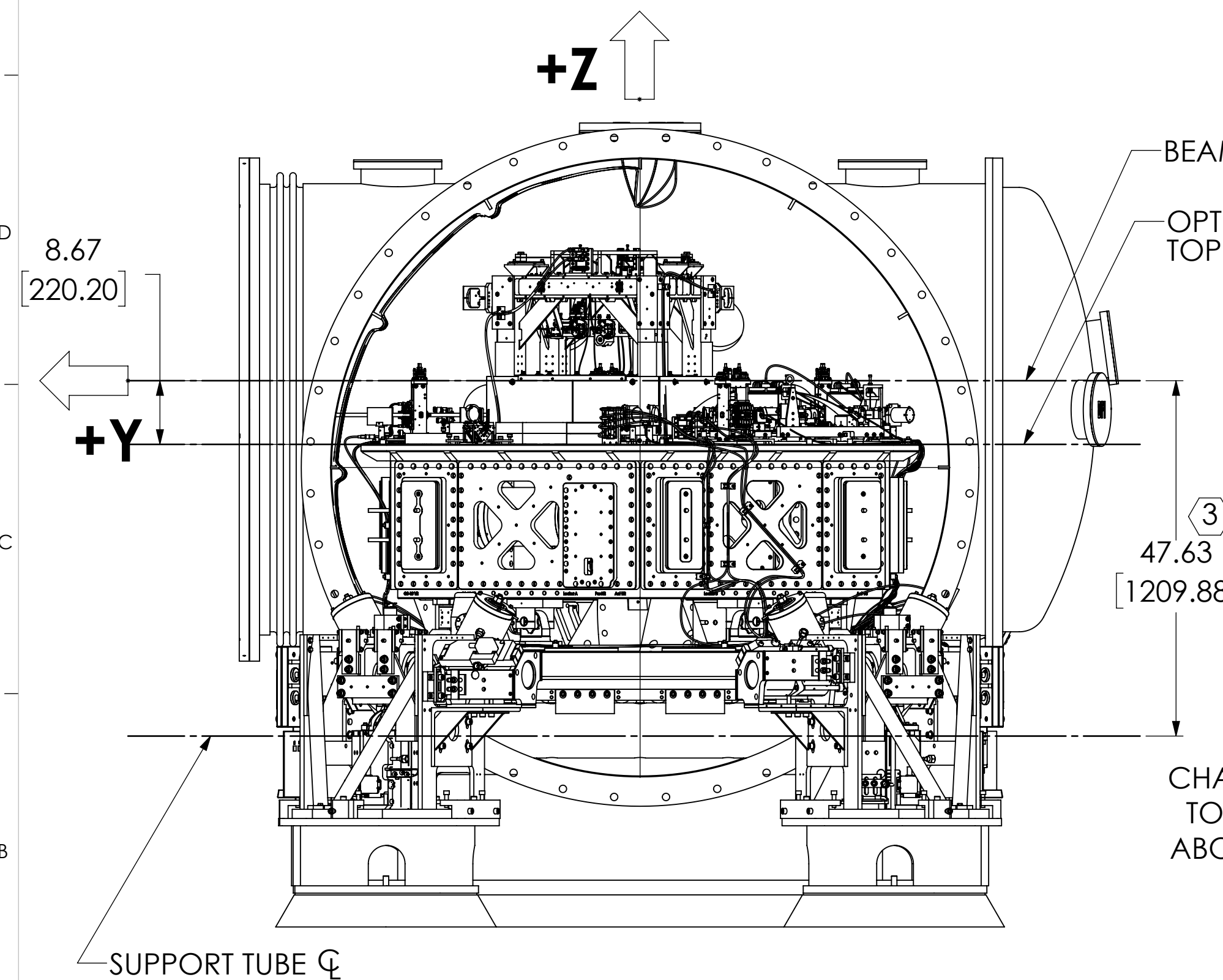
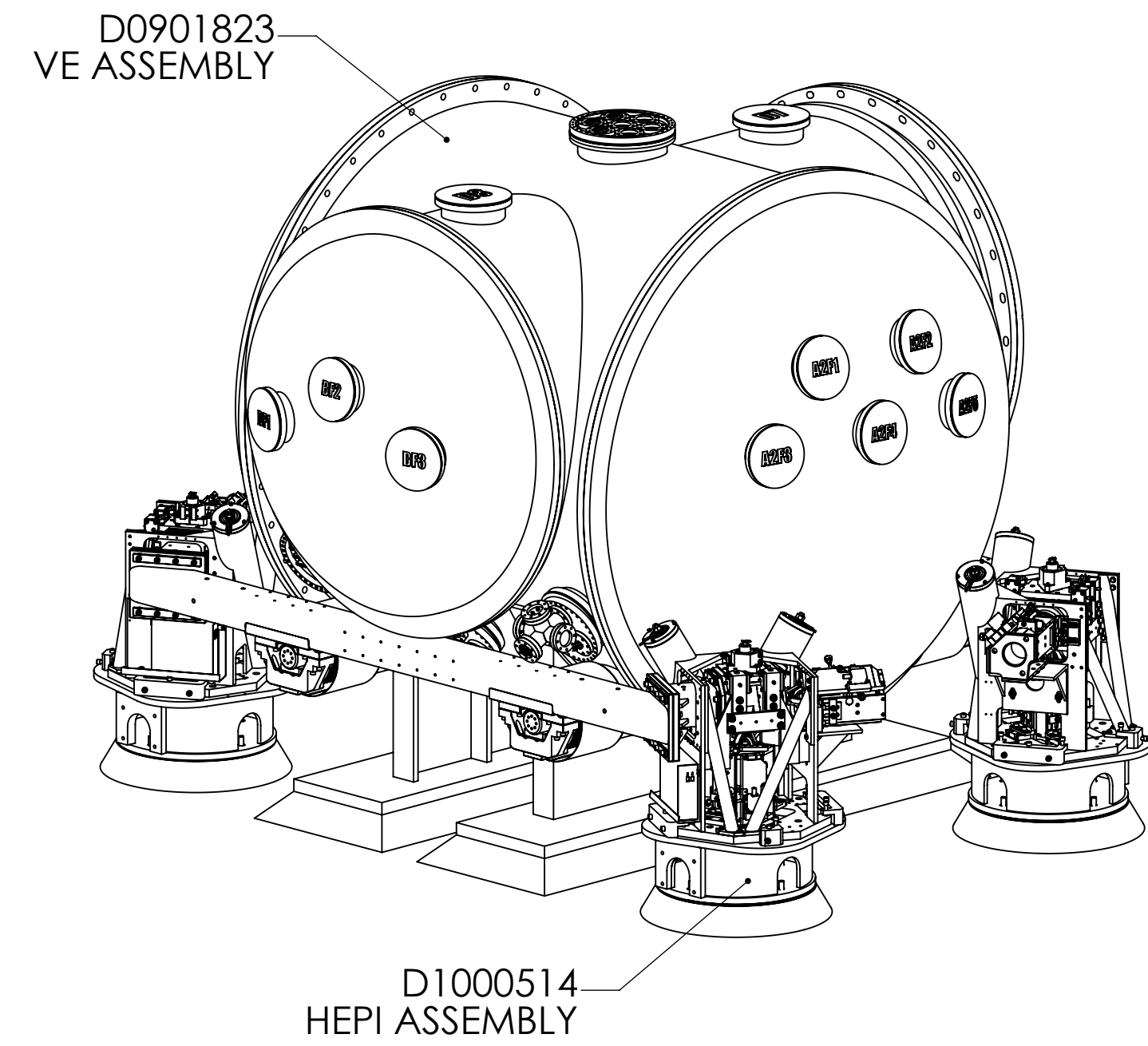
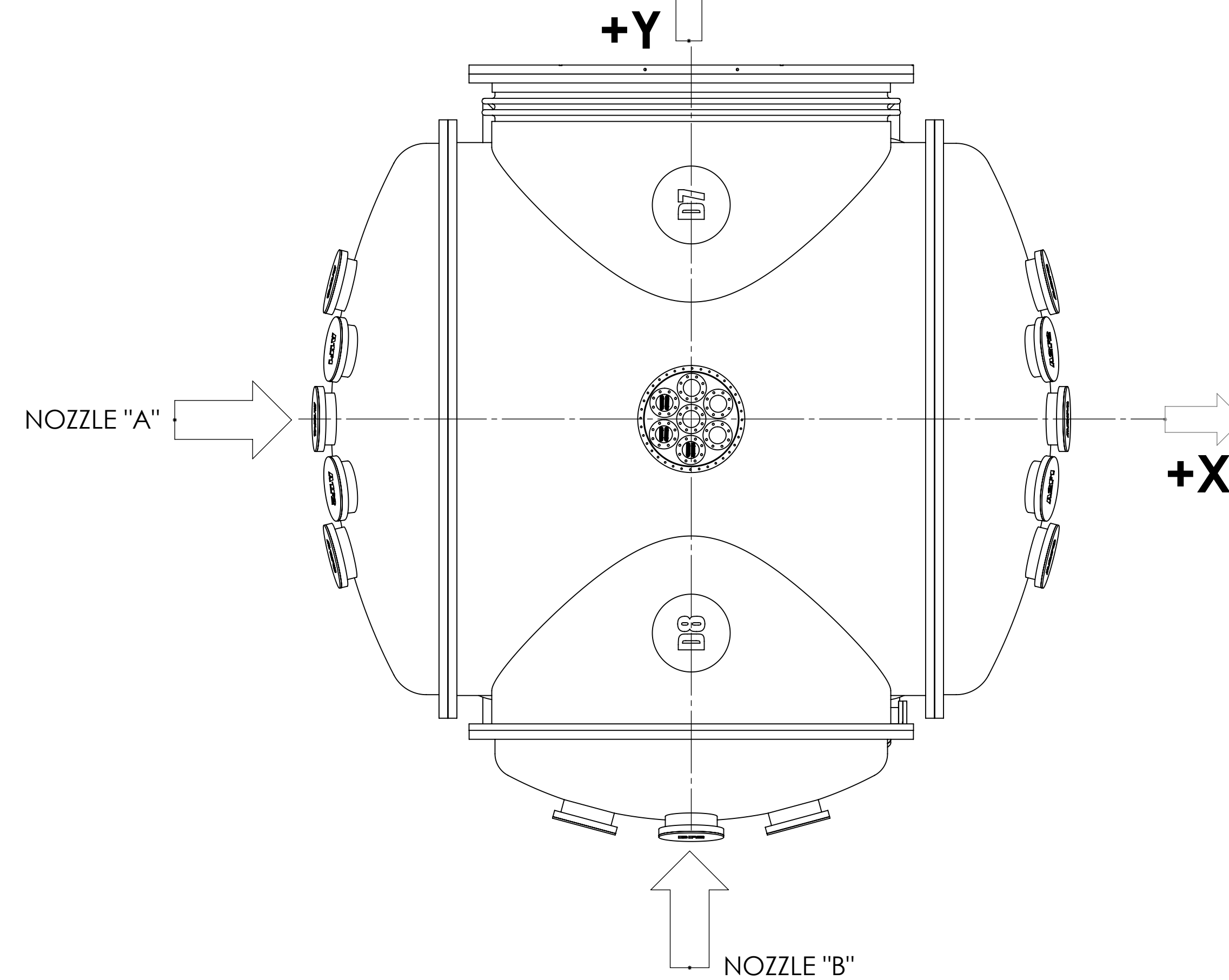

GLOBAL COORDINATES (mm)	
X	0.0
Y	-22692.0
Z	0.0

NOTES AND TOLERANCES: (UNLESS OTHERWISE SPECIFIED)		LIGO CALIFORNIA INSTITUTE OF TECHNOLOGY MASSACHUSETTS INSTITUTE OF TECHNOLOGY		PART NAME	
DIMENSIONS ARE IN INCHES		ADVANCED LIGO		AdvLIGO Systems, HAM6-H1 Top Level Chamber Assembly	
MATERIAL	--	SYSTEM	SUS	DESIGNER	ED CHAVEZ
FINISH	-- μ inch	NEXT ASSY		DRAFTER	19 OCT 2012
				CHECKER	
				APPROVAL	
				SIZE	DWG. NO.
				D	D0901822
				SCALE: 1:16	PROJECTION:
					SHEET 1 OF 4
				REV.	v11

D0901822 AdvLIGO Systems, HAM6-H1 Top Level Chamber Assembly, PART FDM REV. X-033, DRAWING FDM REV. X-015

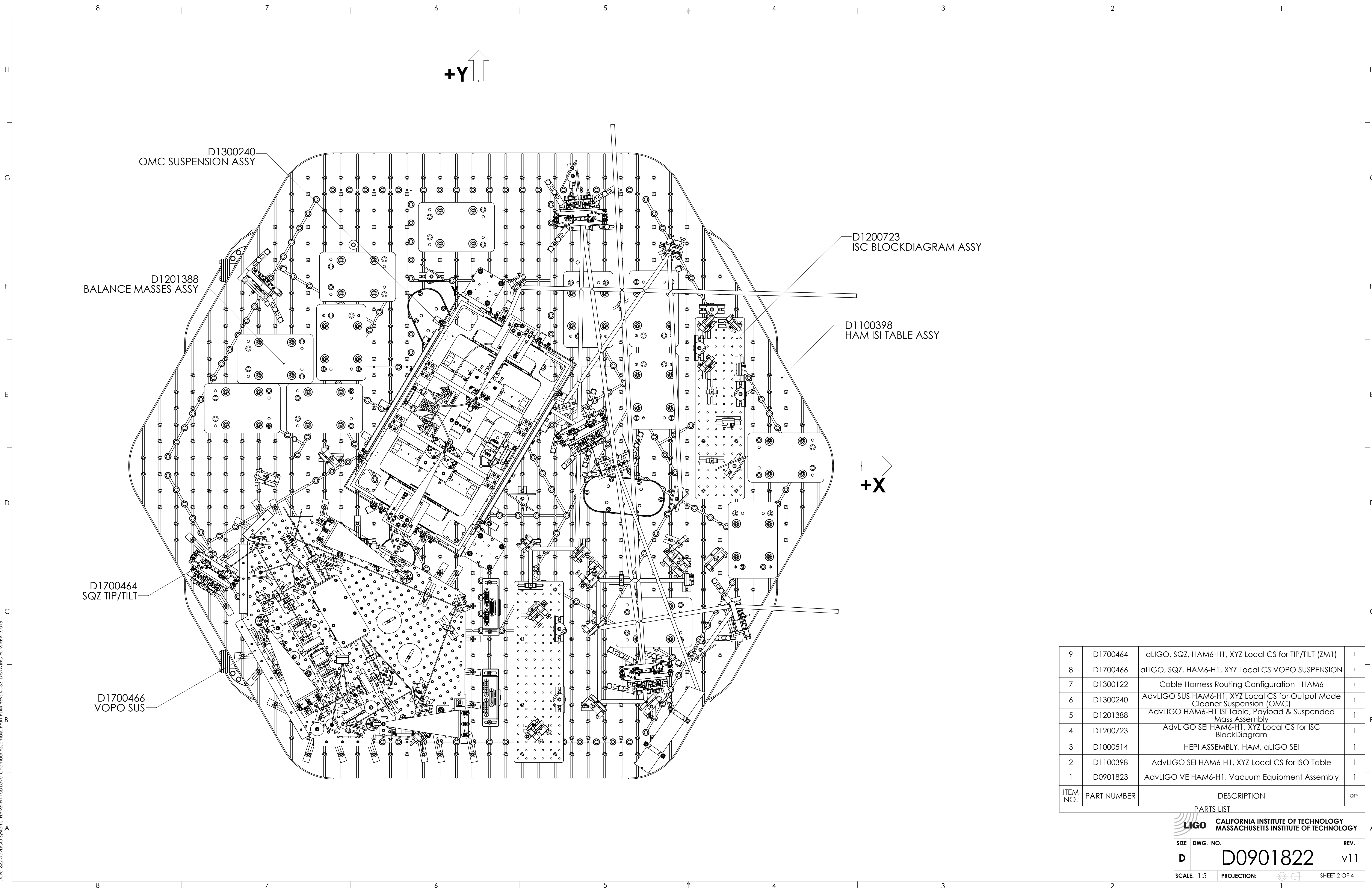

D1300240
OMC SUSPENSION ASSY

D1201388
BALANCE MASSES ASSY

D1200723
ISC BLOCKDIAGRAM ASSY

D1100398
HAM ISI TABLE ASSY

D1700464
SQZ TIP/TILT

D1700466
VOPO SUS

ITEM NO.	PART NUMBER	DESCRIPTION	QTY.
9	D1700464	aLIGO, SQZ, HAM6-H1, XYZ Local CS for TIP/TILT (ZM1)	1
8	D1700466	aLIGO, SQZ, HAM6-H1, XYZ Local CS VOPO SUSPENSION	1
7	D1300122	Cable Harness Routing Configuration - HAM6	1
6	D1300240	AdvLIGO SUS HAM6-H1, XYZ Local CS for Output Mode Cleaner Suspension (OMC)	1
5	D1201388	AdvLIGO HAM6-H1 ISI Table, Payload & Suspended Mass Assembly	1
4	D1200723	AdvLIGO SEI HAM6-H1, XYZ Local CS for ISC BlockDiagram	1
3	D1000514	HEPI ASSEMBLY, HAM, aLIGO SEI	1
2	D1100398	AdvLIGO SEI HAM6-H1, XYZ Local CS for ISO Table	1
1	D0901823	AdvLIGO VE HAM6-H1, Vacuum Equipment Assembly	1

LIGO CALIFORNIA INSTITUTE OF TECHNOLOGY
MASSACHUSETTS INSTITUTE OF TECHNOLOGY

SIZE DWG. NO. REV.
D **D0901822** v11

SCALE: 1:5 PROJECTION: SHEET 2 OF 4

DD901823 AdvLIGO Systems, HAM6-H1 Top Level Chamber Assembly, PART FDM REV. X-033, DRAWING FDM REV. X-015

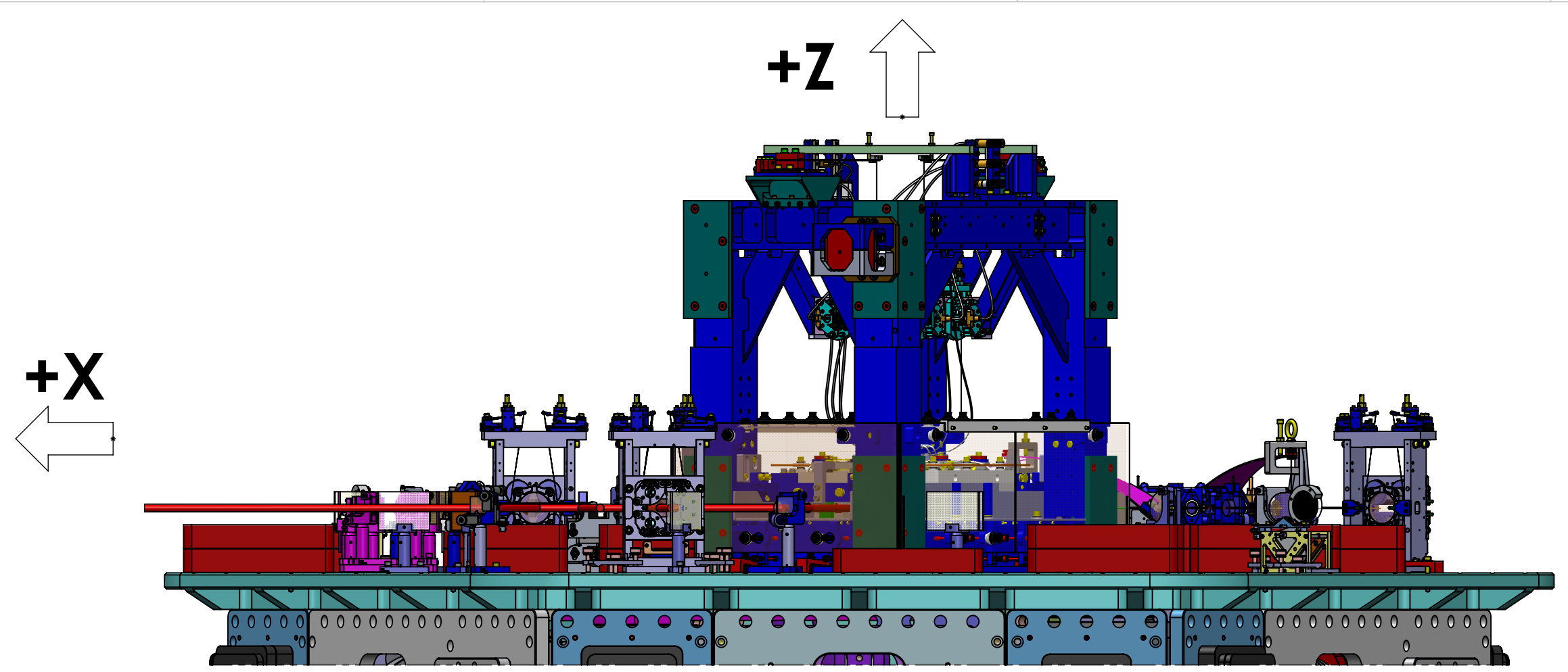

REAR VIEW
(ROTATED 180 DEGREES CCW)

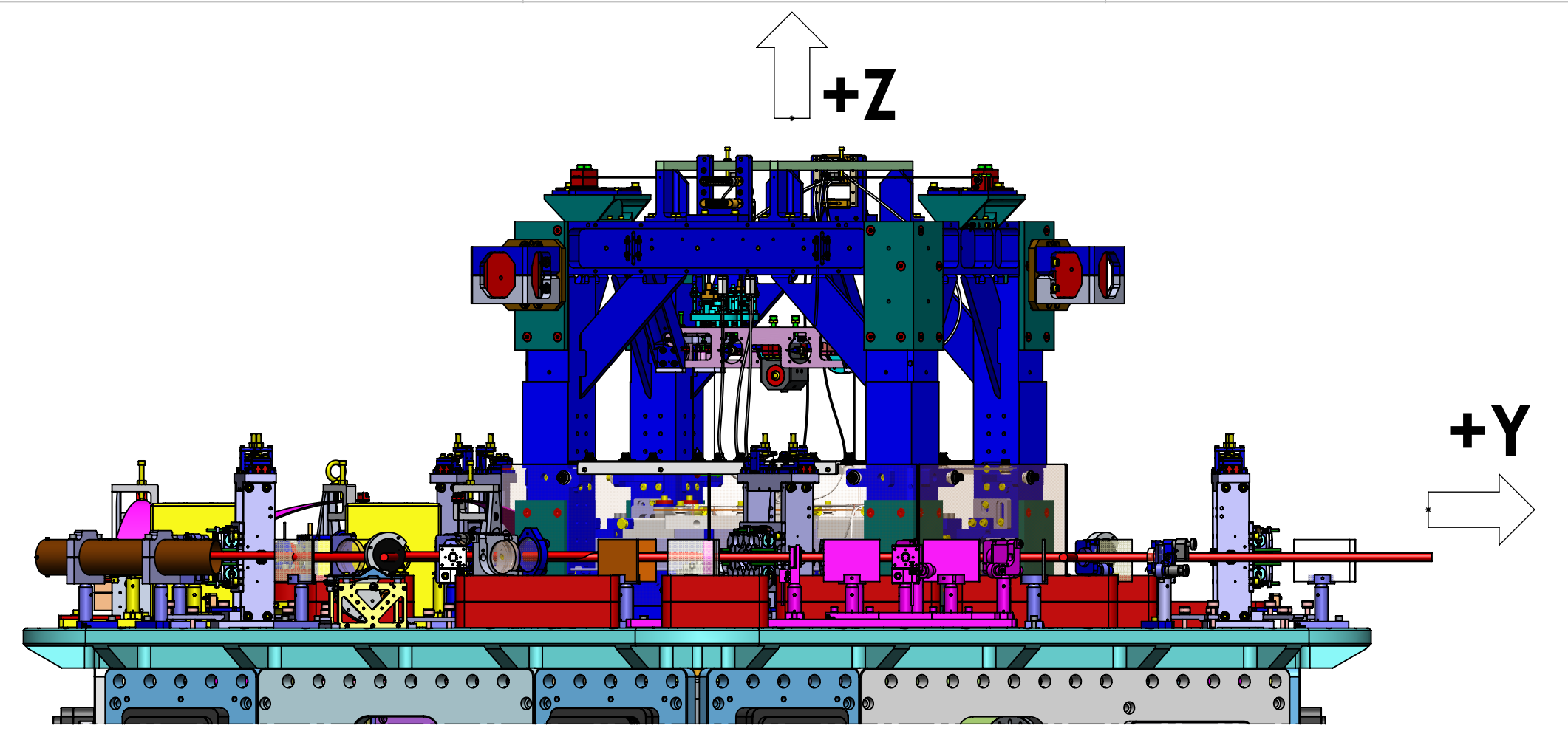

RIGHT SIDE VIEW
(ROTATED 180 DEGREES CCW)

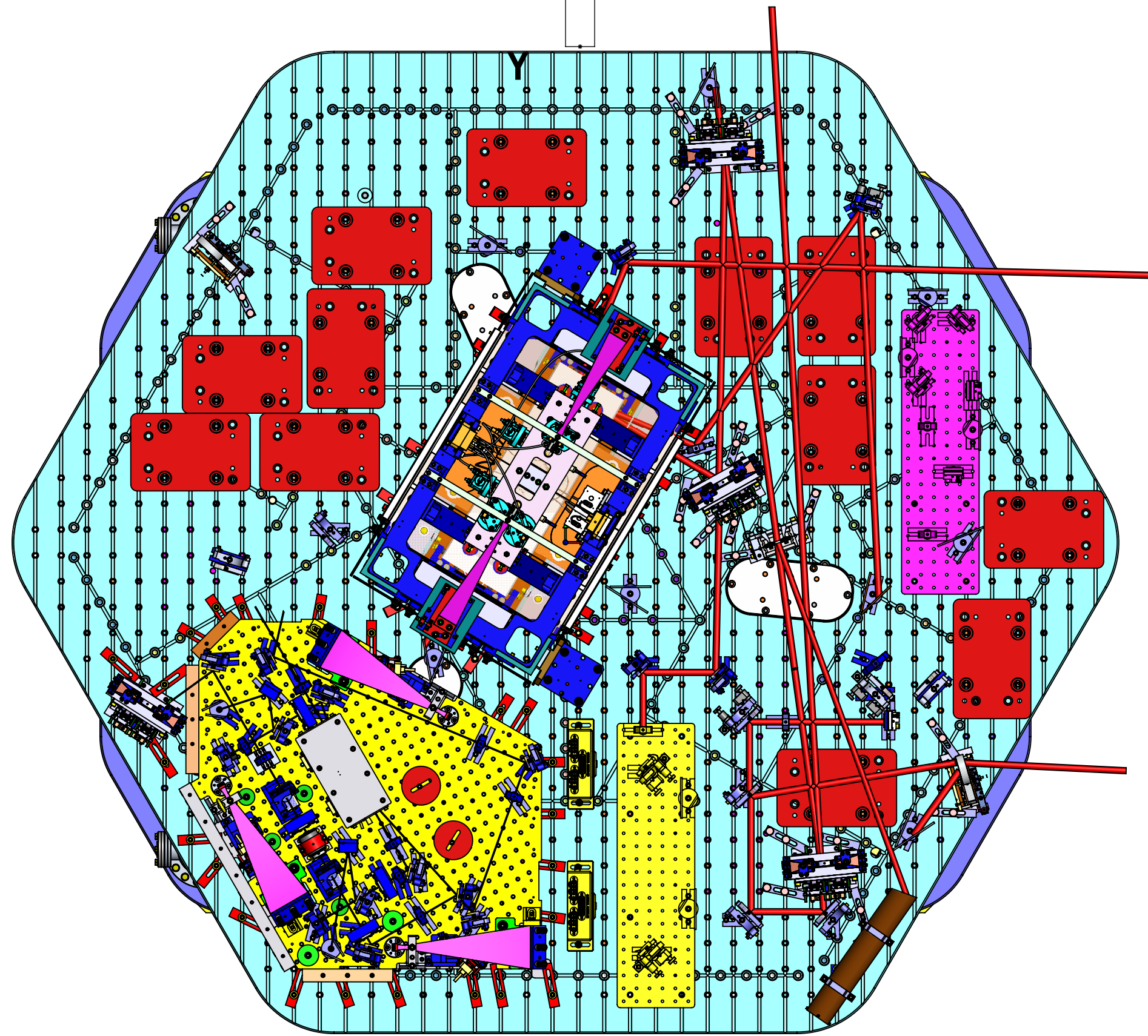

TOP VIEW

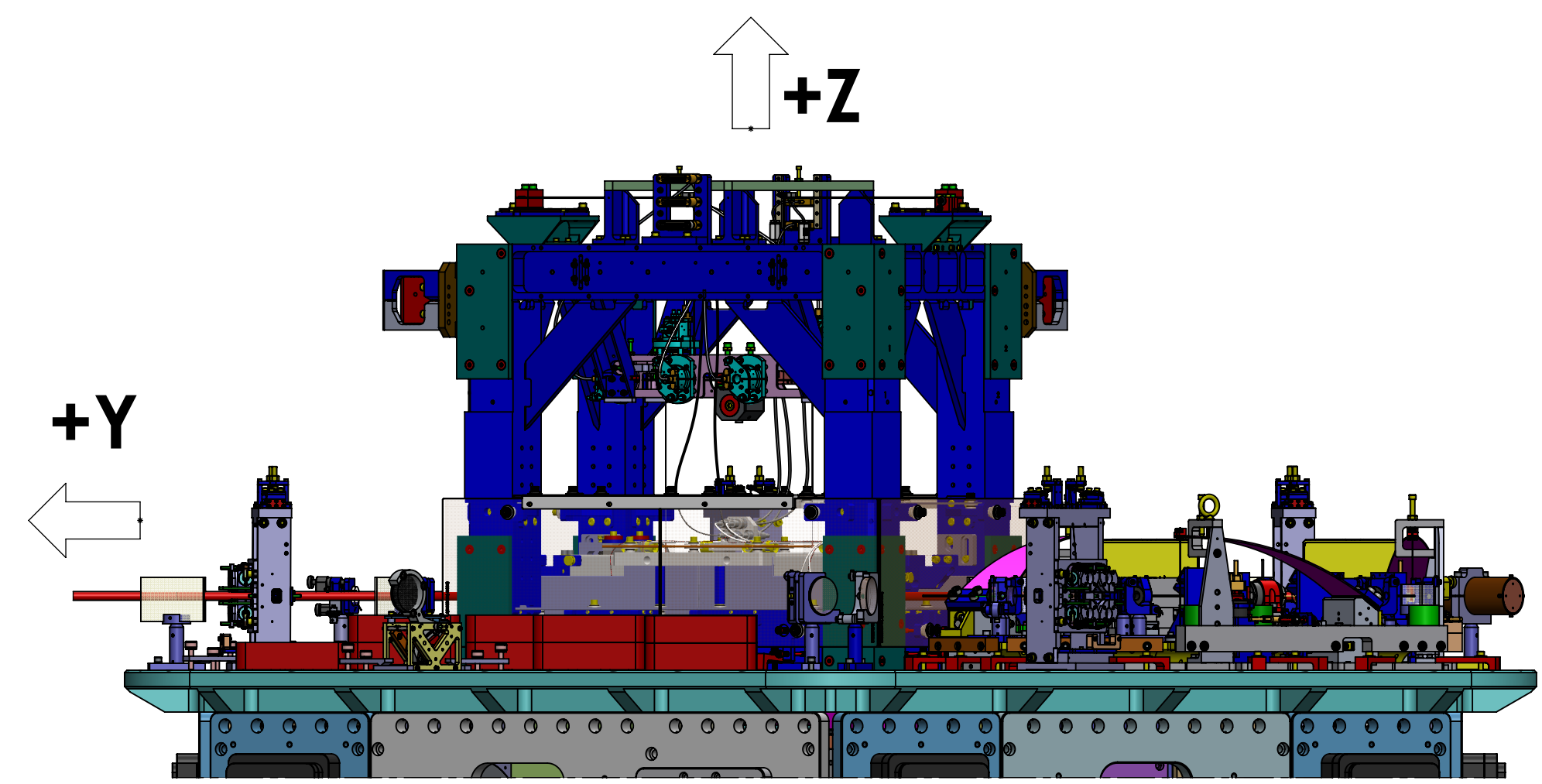

LEFT SIDE VIEW
(ROTATED 90 DEGREES CCW)

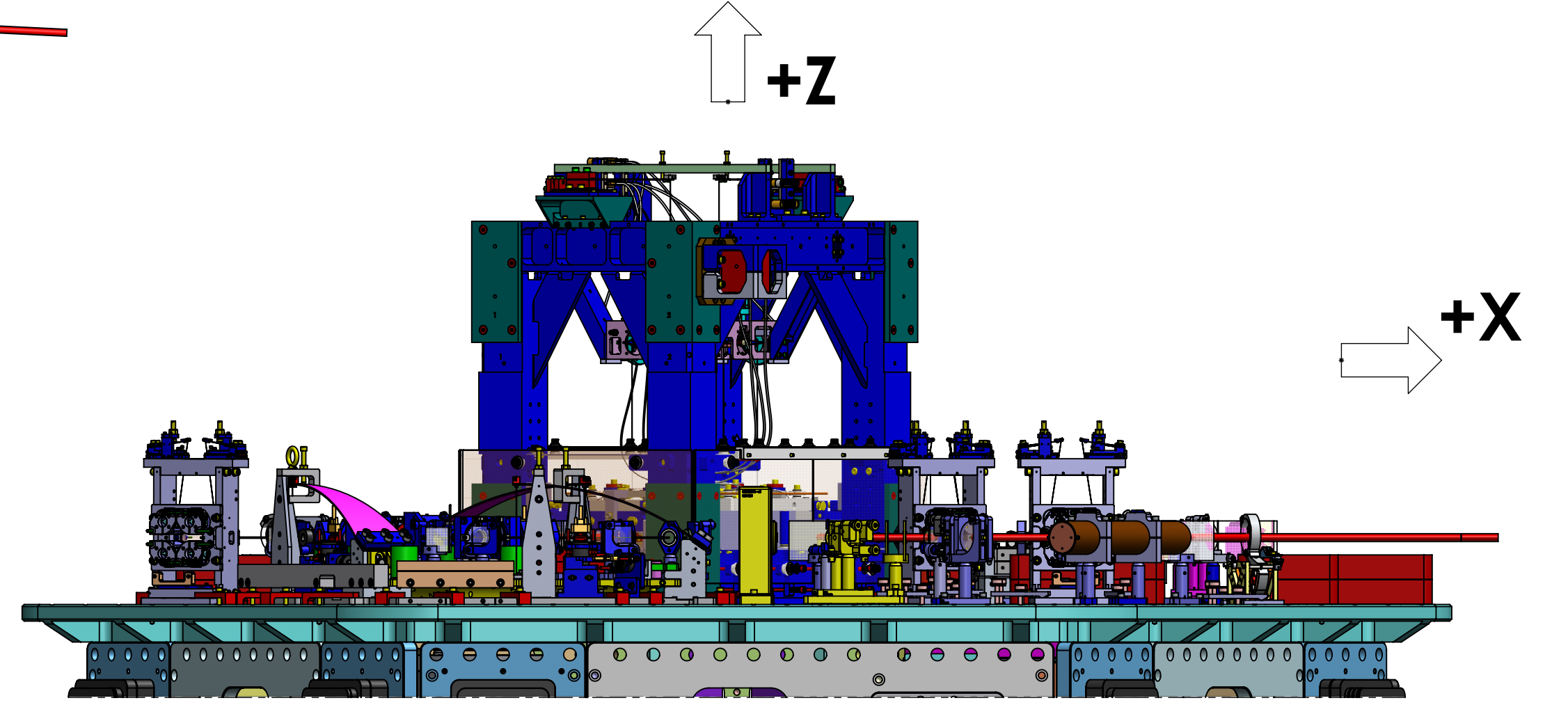

FRONT VIEW

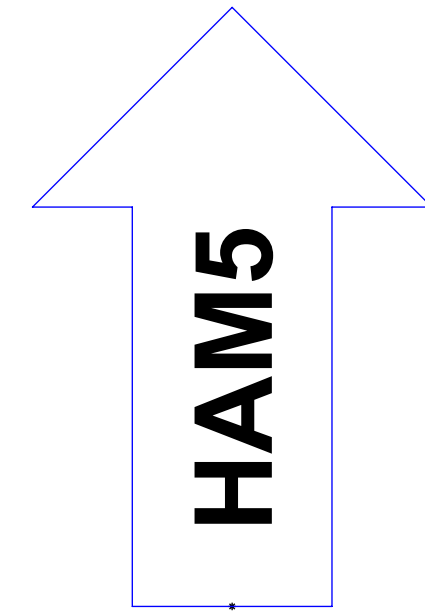
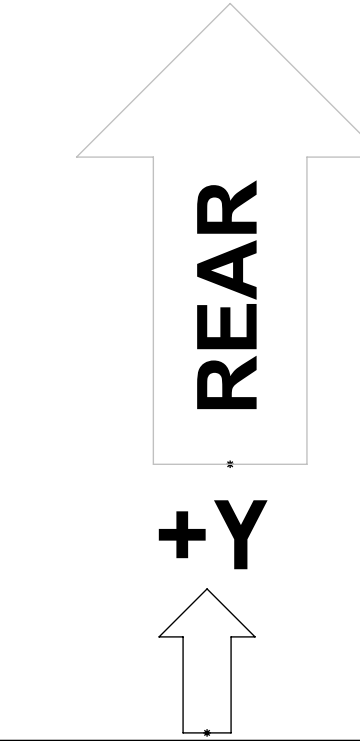
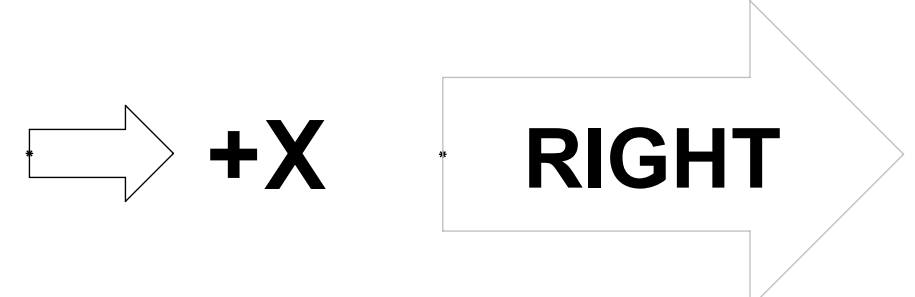
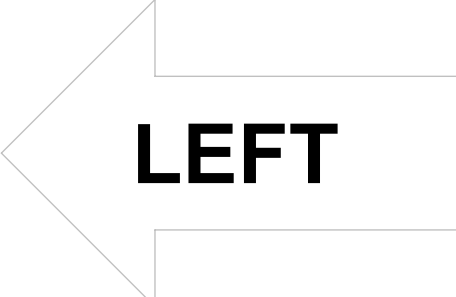
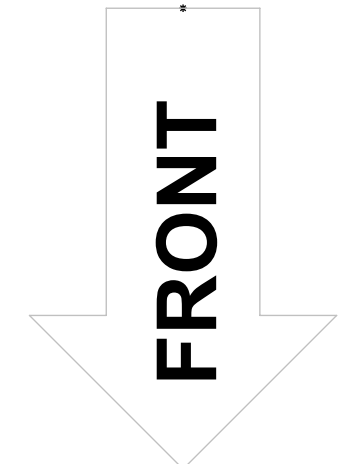

LASER BEAMS - ORTHO VIEWS

CALIFORNIA INSTITUTE OF TECHNOLOGY MASSACHUSETTS INSTITUTE OF TECHNOLOGY		REV.
SIZE DWG. NO.	D0901822	v11
SCALE: 1:8	PROJECTION:	SHEET 3 OF 4

DD901822.A01/LCO Systems: HAM5-H1 Top Level Chamber Assembly: PART FDM REV: X-033.DRAWING FDM REV: X-015

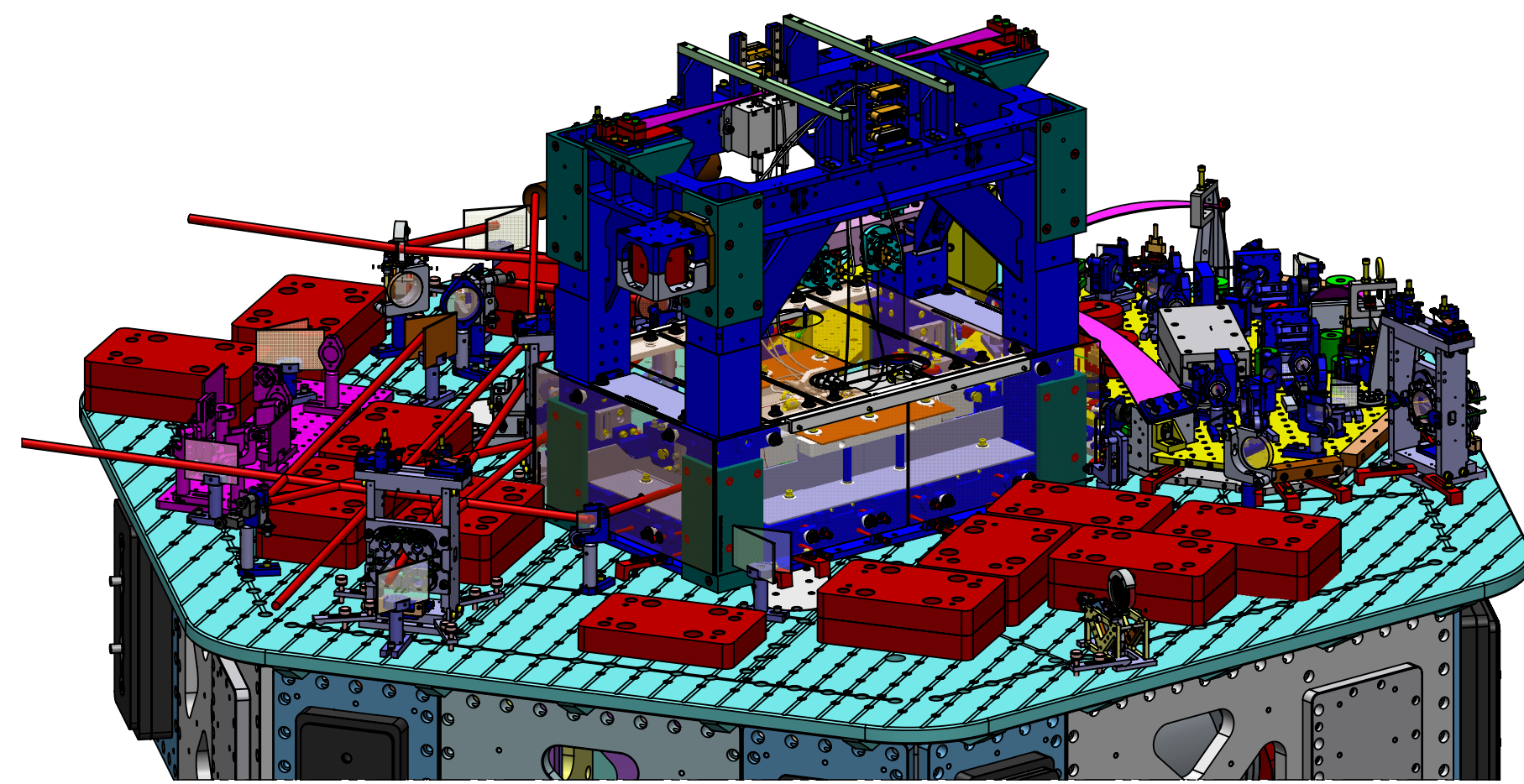

ISO VIEW, REAR LEFT

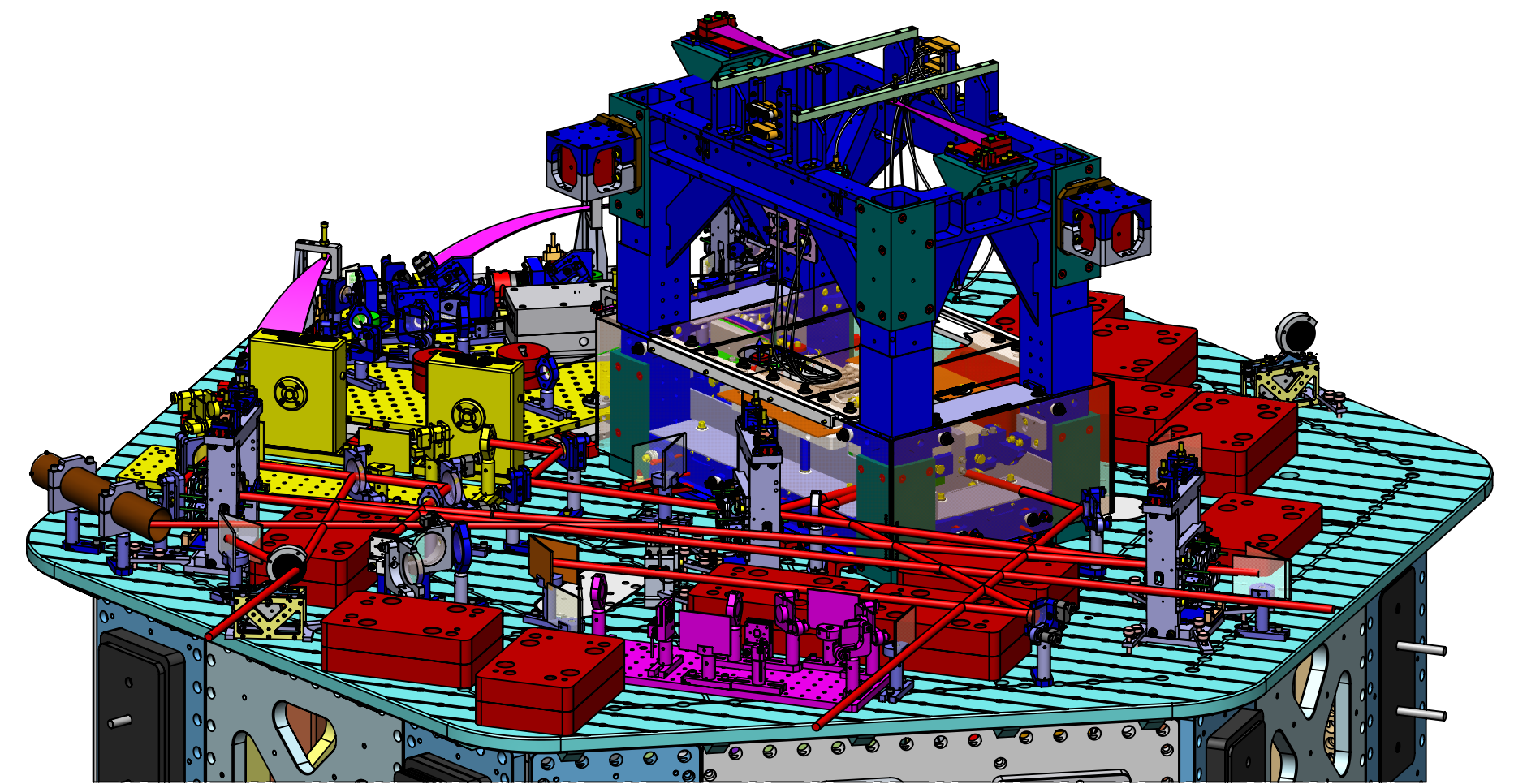

ISO VIEW, REAR RIGHT

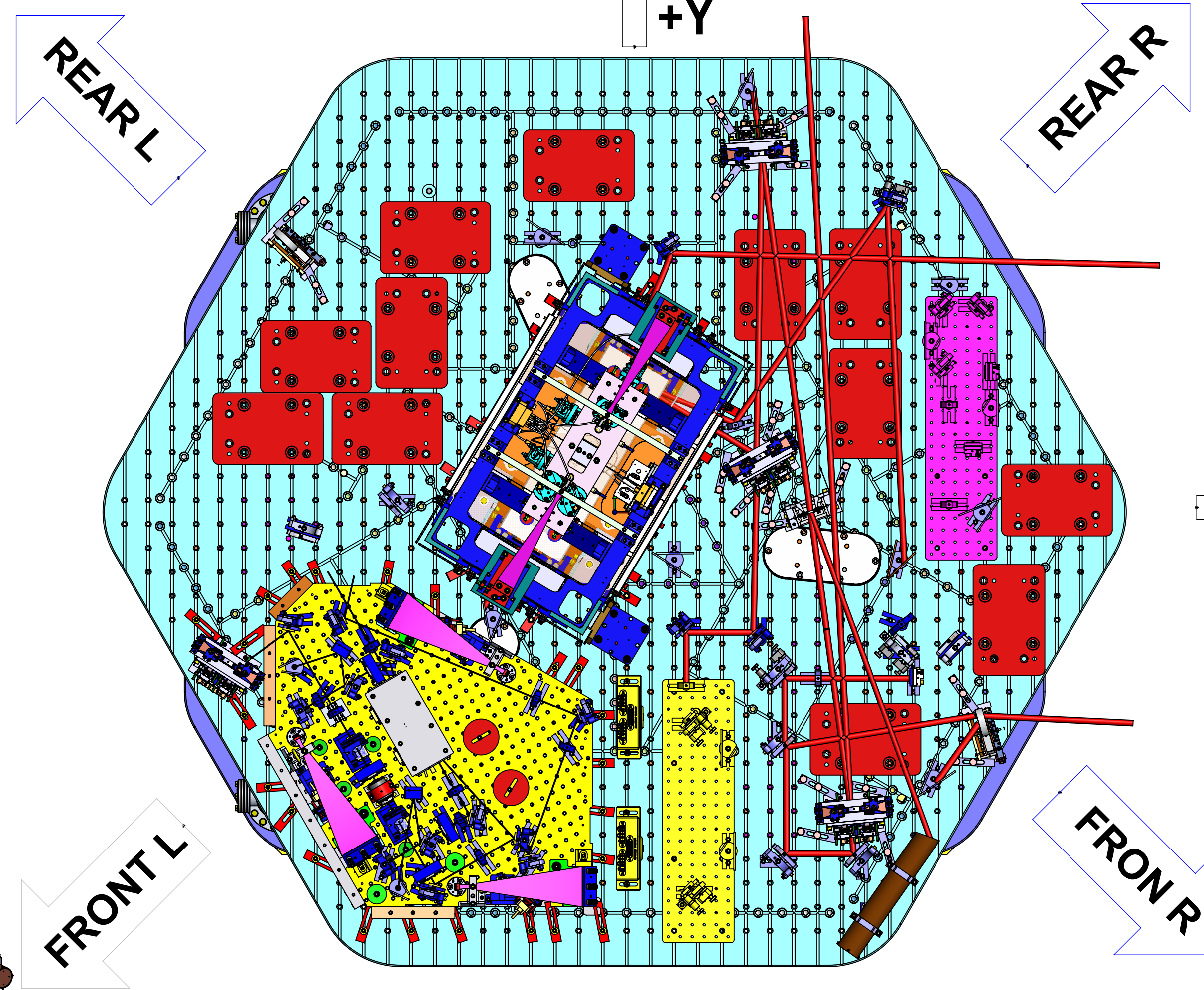

TOP VIEW

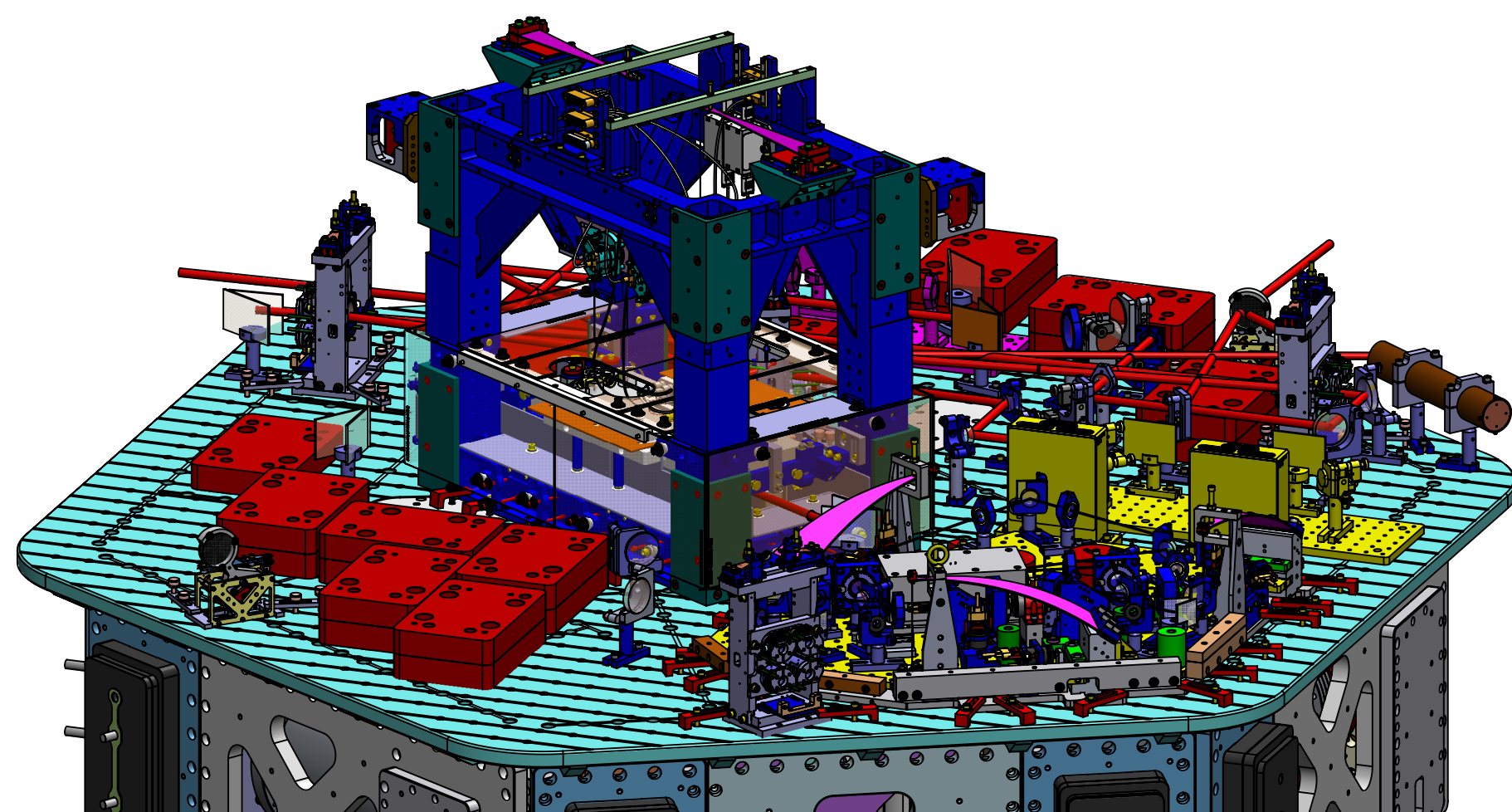

ISO VIEW, FRONT LEFT

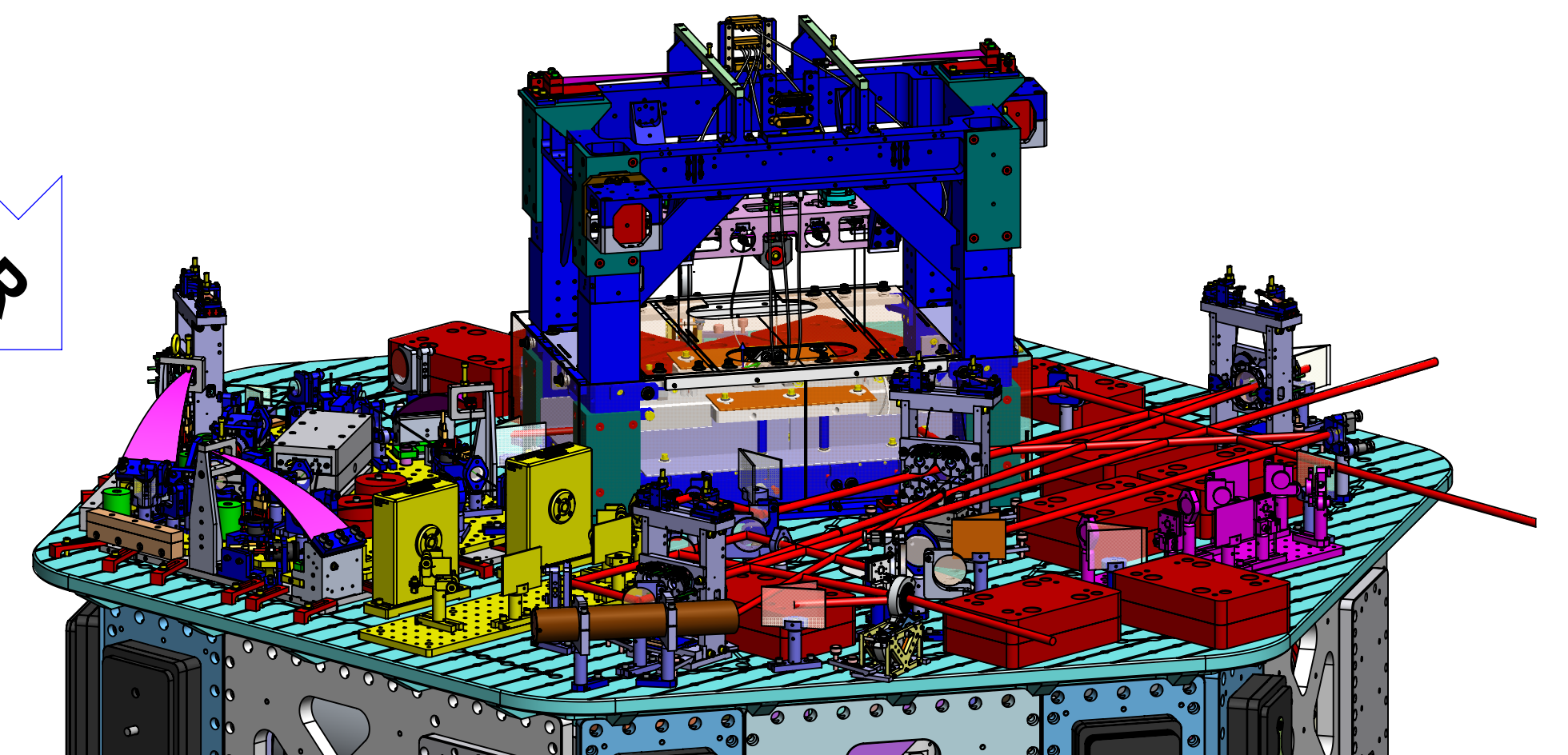

ISO VIEW, FRONT RIGHT

LASER BEAMS - ISO VIEWS

LIGO CALIFORNIA INSTITUTE OF TECHNOLOGY MASSACHUSETTS INSTITUTE OF TECHNOLOGY	
SIZE DWG. NO.	REV.
D D0901822	v11
SCALE: 1:8	PROJECTION: SHEET 4 OF 4

DD901822-Asst LIGO Systems: HAM5-H1 Top Level Chamber Assembly: PART FDM REV: X-033_L DRAWING FDM REV: X-015