

4

3

2

1

NOTES CONTINUED:

5 SCRIBE, ENGRAVE, OR MECHANICALLY STAMP (NO INKS OR DYES) DRAWING PART NUMBER AND REVISION ON NOTED SURFACE FOLLOWED ON THE NEXT LINE BY A THREE DIGIT SERIAL NUMBER. SERIAL NUMBERS START AT 001 FOR THE FIRST ARTICLE AND PROCEED CONSECUTIVELY. USE .07" HIGH CHARACTERS. EXAMPLE: DXXXXXX-VY, S/N 001. A VIBRATORY TOOL MAY BE USED.

REV.	DATE	DCN #	DRAWING TREE #
v1	02 AUG 2009	E0900225	E080191
-	-	-	-
-	-	-	-

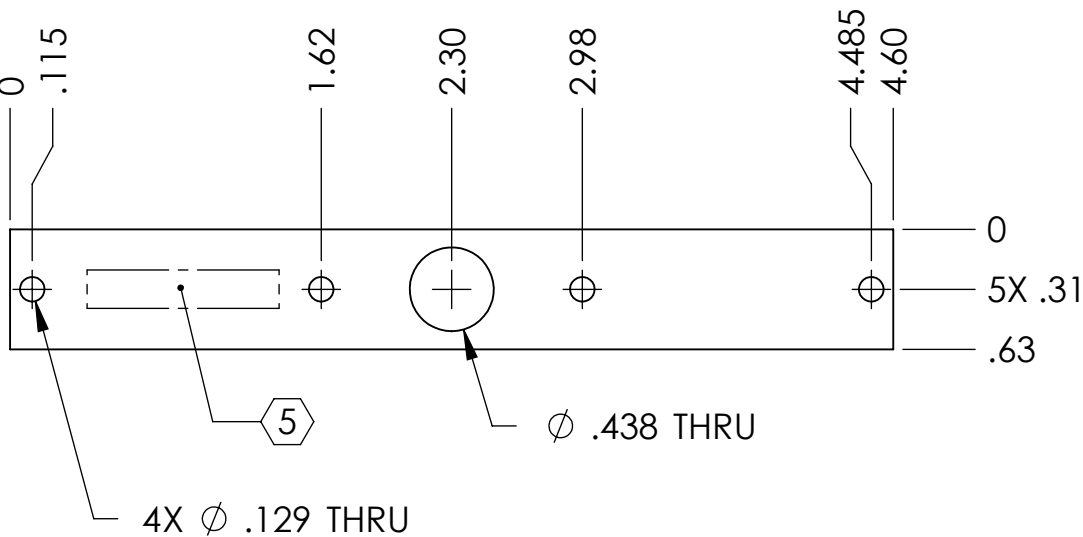
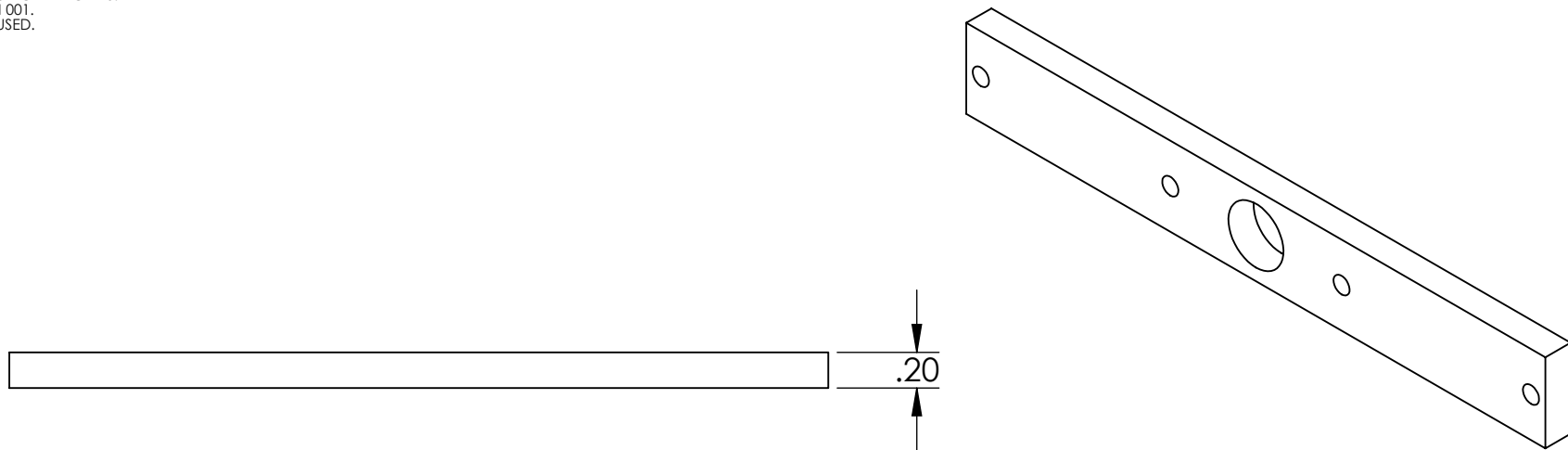

NOTES AND TOLERANCES: (UNLESS OTHERWISE SPECIFIED)

DIMENSIONS ARE IN INCHES

TOLERANCES:  
.XX ± .01  
.XXX ± .005

ANGULAR ± 0.5°

1. INTERPRET DRAWING PER ASME Y14.5-1994.
2. REMOVE ALL SHARP EDGES, R.02 MIN.
3. DO NOT SCALE FROM DRAWING.
4. ALL MACHINING FLUIDS SHALL BE WATER SOLUBLE AND FREE OF SULFUR, CHLORINE AND SILICONE, SUCH AS CINCINNATI MILACRON'S CIMTECH 410.

MATERIAL

6061-T6 Al

FINISH

32 μinch



CALIFORNIA INSTITUTE OF TECHNOLOGY  
MASSACHUSETTS INSTITUTE OF TECHNOLOGY

SYSTEM

ADVANCED LIGO

SUB-SYSTEM

SUS

NEXT ASSY

40-METER CABLE CLAMP

PART NAME

TOP PLATE

DESIGNER D. BRIDGES 02 AUG 2009

DRAFTER D. BRIDGES 02 AUG 2009

CHECKER M. MEYER 03 AUG 2009

APPROVAL

SIZE DWG. NO.

A

D0901547

REV.

v1

SCALE: 1:1

PROJECTION:



SHEET 1 OF 1

4

3

2

1