

REV.	DATE	DCN #	DRAWING TREE #
B	21/DEC/07	E060260-B	
C	22/JULY/08	E080372	

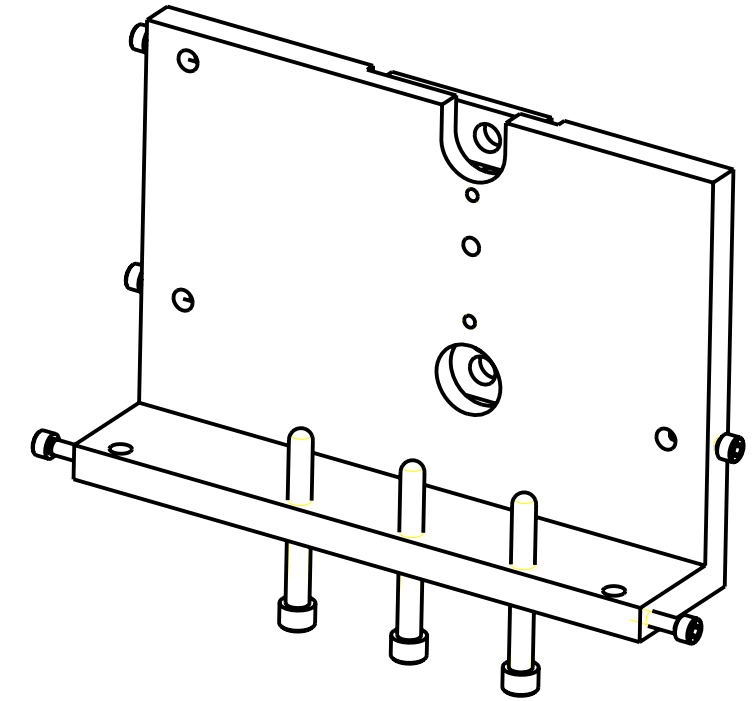
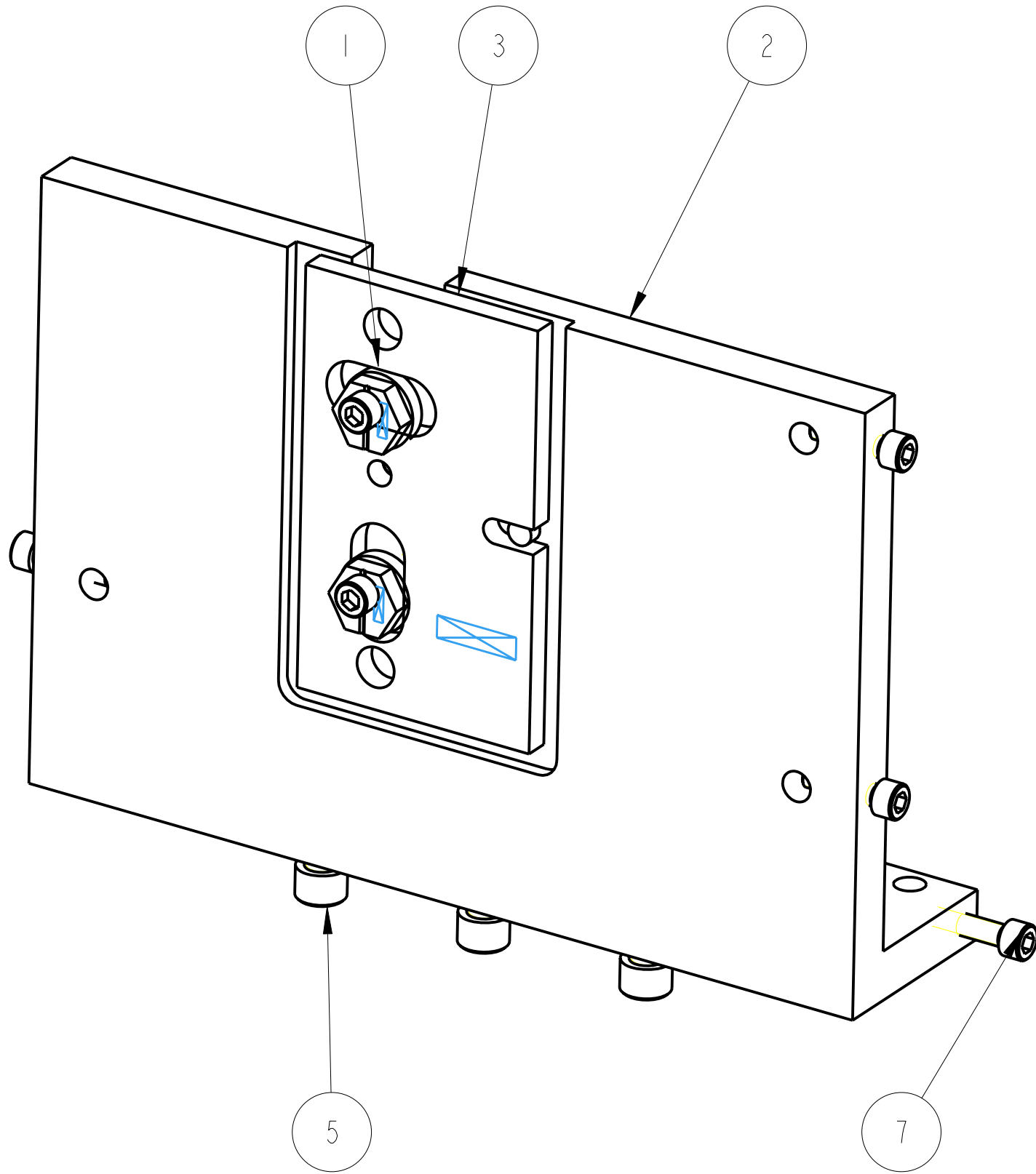

ITEM	QTY	SPARE	TOTAL	PART NUMBER	DESCRIPTION	MATERIALS
1	2			D060336	2MM CAM; OSEM ADJUSTER	PH BRONZE: -----
2	1			D070545	TEST CHAIN UIM STOP; LEFT HAND	AL ALLOY: 6061
3	1			D070548	UIM MASS STOP; BOTH CHAINS	AL ALLOY: 5083
4	3				1/4-20 x 1.5D UNC THREAD INSERT; .	
5	3				1/4" 20 UNC X 2" CAP HEAD, SPHERICAL TIP; .	ST STEEL: 304/316
6	2				8-32 x 1.5D UNC THREAD INSERT; .	
7	7				8-32 UNC X 0.625" CAP HEAD; .	ST STEEL: 304/316

PARTS LIST

NOTES: (UNLESS OTHERWISE SPECIFIED)

- REMOVE ALL SHARP EDGES, R.02 MIN.
- DO NOT SCALE FROM DRAWING.
- ALL MACHINING FLUIDS SHALL BE WATER SOLUBLE AND FREE OF SULFUR, CHLORINE AND SILICONE, SUCH AS CINCINNATI MILACRON'S CIMTECH 410 (STAINLESS STEEL)
- SCRIBE, ENGRAVE OR STAMP DRAWING PART NUMBER ON NOTED SURFACE OF PART AND A THREE DIGIT SERIAL NUMBER. SERIAL NUMBERS START AT 001 FOR THE FIRST PART AND PROCEED CONSECUTIVELY. USE .07" HIGH CHARACTERS. EXAMPLE: D020188- 001. A VIBRATORY TOOL MAY BE USED.

DIMENSIONS ARE IN mm [INCHES]
TOLERANCES:

X.XX ±N/A mm
ANGULAR ±N/A °

MATERIAL: AS DRW
AS DRW

FINISH: AS DRW
√μm [μin] Ra = AS DRW

	NAME	DATE
DRAWN	I WILMUT	05/Dec/07
CHECKED	MB	15/MAR/10
APPROVED	JOD	15/MAR/10

100 CALIFORNIA INSTITUTE OF TECHNOLOGY
MASSACHUSETTS INSTITUTE OF TECHNOLOGY
IGR, GLASGOW UNIVERSITY GEO 600 GROUP
RUTHERFORD APPLETON LABORATORIES

SYSTEM **aLIGO**
SUB-SYSTEM **SUS**
NEXT ASSY **D060454**
PART NAME **UIM TC E'QUAKE STOP ASSY #1**

SIZE **B** DRG. NO. **D070540** REV **E.**
SCALE 1:1 PROJECTION: SHEET 1 OF 1