

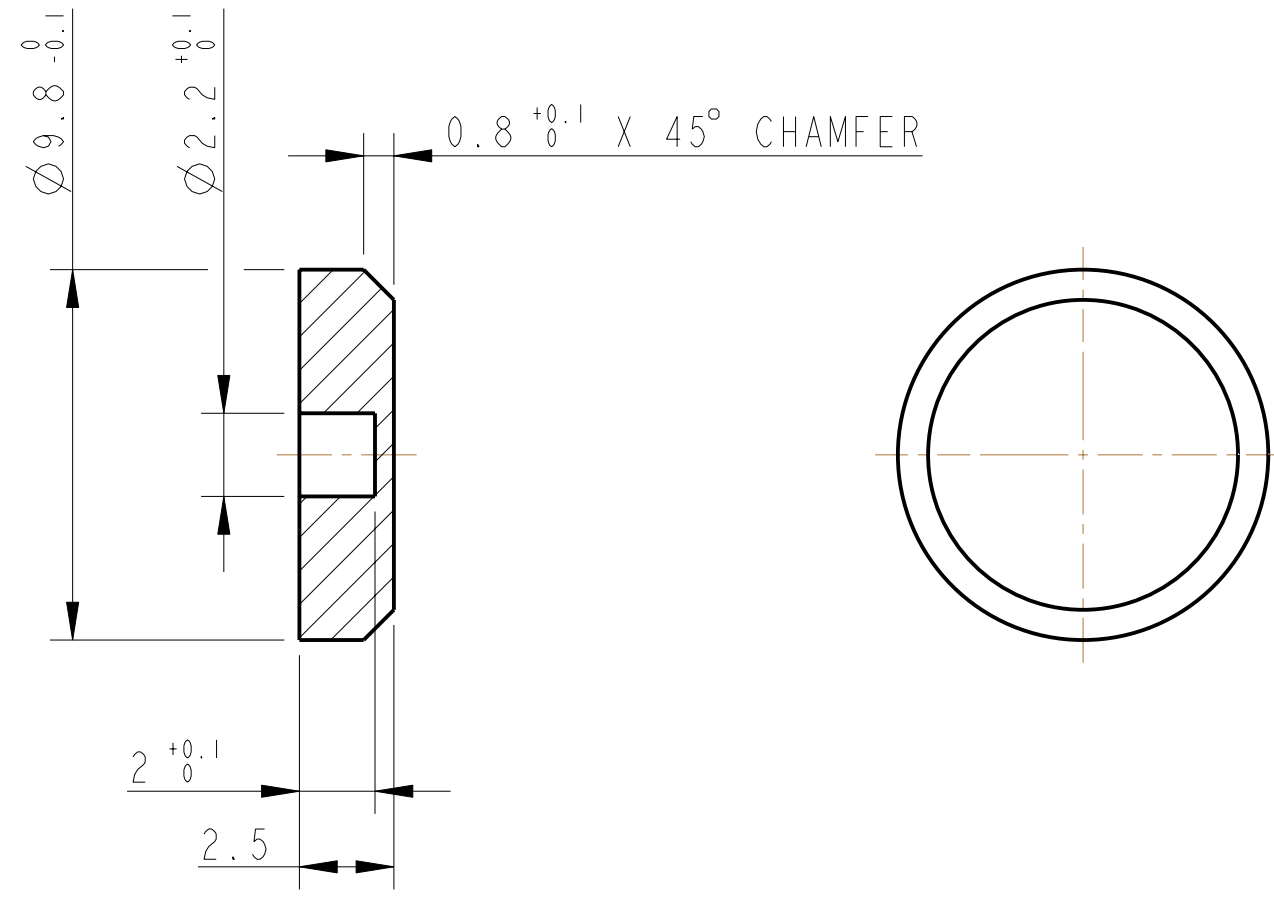

REV.	DATE	DCN #	DRAWING TREE #

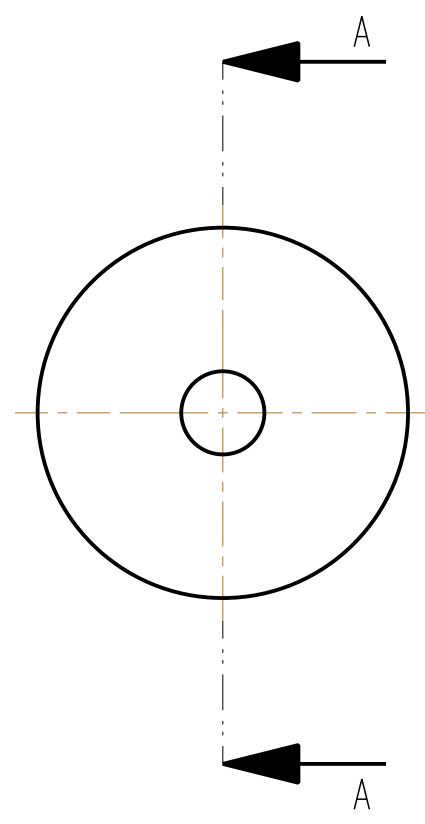

SECTION A-A

NOTES: (UNLESS OTHERWISE SPECIFIED)		 CALIFORNIA INSTITUTE OF TECHNOLOGY MASSACHUSETTS INSTITUTE OF TECHNOLOGY IGR, GLASGOW UNIVERSITY GEO 600 GROUP RUTHERFORD APPLETON LABORATORIES								
1. REMOVE ALL SHARP EDGES, R.02 MIN. 2. DO NOT SCALE FROM DRAWING. 3. ALL MACHINING FLUIDS SHALL BE WATER SOLUBLE AND FREE OF SULFUR, CHLORINE AND SILICONE, SUCH AS CINCINNATI MILACRON'S CIMTECH 410 (STAINLESS STEEL) 4. SCRIBE, ENGRAVE OR STAMP DRAWING PARTNUMBER ON NOTED SURFACE OF PART AND A THREE DIGIT SERIAL NUMBER. SERIAL NUMBERS START AT 001 FOR THE FIRST PART AND PROCEED CONSECUTIVELY. USE .07" HIGH CHARACTERS. EXAMPLE: D020188- 001. A VIBRATORY TOOL MAY BE USED.	DIMENSIONS ARE IN mm [INCHES] TOLERANCES: X.XX $\pm 0.2$ mm ANGULAR $\pm 0.25^\circ$		SYSTEM <b>aLIGO</b>							
	MATERIAL: AL/ALLOY 5083 OR SIMILAR		SUB-SYSTEM <b>SUS</b>							
	FINISH: CLEAN AND DEGREASED $\sqrt{\mu m}$ [ $\mu in$ ] $R_a = 1.6$		NEXT ASSY <b>PEN RE MASS MAGNETS</b>							
	<table border="1"> <tr> <th>NAME</th> <th>DATE</th> </tr> <tr> <td>DRAWN J O'DELL</td> <td>04/JUN/07</td> </tr> <tr> <td>CHECKED MB</td> <td>15/MAR/10</td> </tr> <tr> <td>APPROVED JOD</td> <td>15/MAR/10</td> </tr> </table>		NAME	DATE	DRAWN J O'DELL	04/JUN/07	CHECKED MB	15/MAR/10	APPROVED JOD	15/MAR/10
NAME	DATE									
DRAWN J O'DELL	04/JUN/07									
CHECKED MB	15/MAR/10									
APPROVED JOD	15/MAR/10									
SCALE 5:1 PROJECTION: 		SIZE <b>B</b> DRG. NO. <b>D070237</b>	REV <b>F.</b>							
		SHEET 1 OF 1								