

REV.	DATE	DCN #	DRAWING TREE #

1 mm x 45°
BREAK EDGE

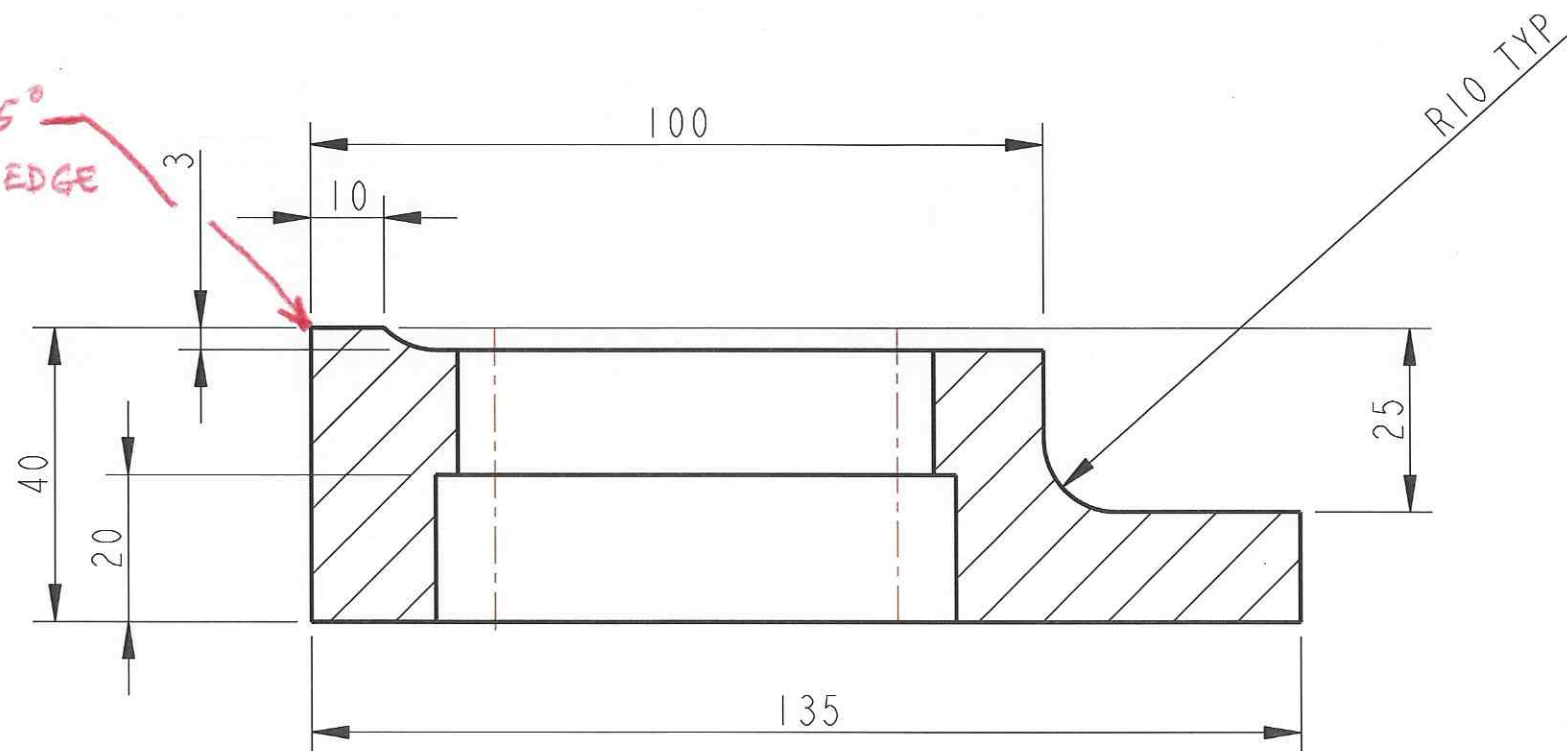

SECTION A-A

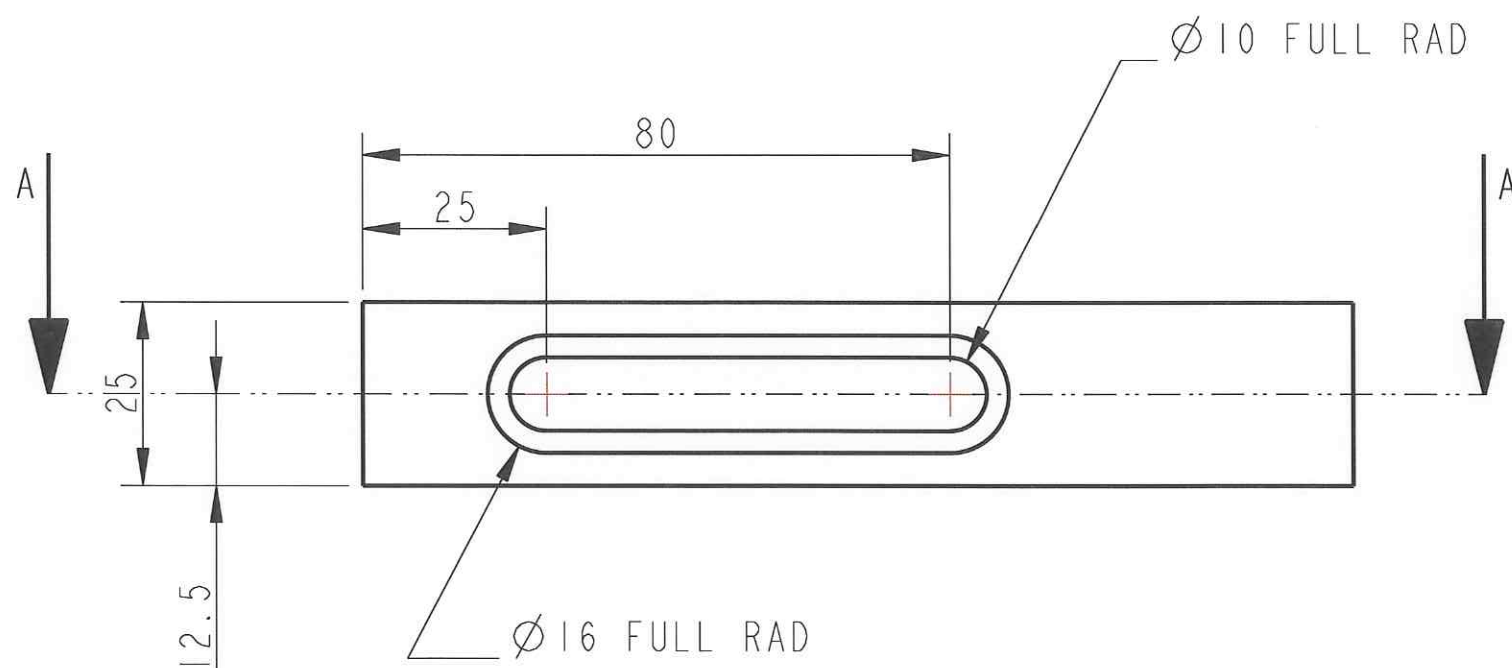

NOTES: (UNLESS OTHERWISE SPECIFIED)

1. REMOVE ALL SHARP EDGES, R.02 MIN.
2. DO NOT SCALE FROM DRAWING.
3. ALL MACHINING FLUIDS SHALL BE WATER SOLUBLE AND FREE OF SULFUR, CHLORINE AND SILICONE, SUCH AS CINCINNATI MILACRON'S CIMTECH 410 (STAINLESS STEEL)
4. SCRIBE, ENGRAVE OR STAMP DRAWING PARTNUMBER ON NOTED SURFACE OF PART AND A THREE DIGIT SERIAL NUMBER. SERIAL NUMBERS START AT 001 FOR THE FIRST PART AND PROCEED CONSECUTIVELY. USE .07" HIGH CHARACTERS. EXAMPLE: D020188-001. A VIBRATORY TOOL MAY BE USED.

DIMENSIONS ARE IN mm [INCHES]
TOLERANCES:

X.XX ±0.2 mm
ANGULAR ±0.25°

MATERIAL: ST STEEL
304 OR 316

FINISH: CLEAN AND DEGREASED
√μm [μin] Ra = 1.6

	NAME	DATE
DRAWN	I WILMUT	22/Feb/07
CHECKED	MB	15/MAR/10
APPROVED	JOD	15/MAR/10

CALIFORNIA INSTITUTE OF TECHNOLOGY
MASSACHUSETTS INSTITUTE OF TECHNOLOGY
IGR, GLASGOW UNIVERSITY GEO 600 GROUP
RUTHERFORD APPLETON LABORATORIES

SYSTEM **aLIGO**
SUB-SYSTEM **SUS**
NEXT ASSY **QUAD**
PART NAME **QUAD DOG CLAMP**

SCALE 1:1 PROJECTION: SHEET 1 OF 1

REV. **B.**

DRG. NO. **D070056**