

REV.	DATE	DCN #	DRAWING TREE #
A	30-OCT-06	E060260-00	
B	21/DEC/07	E060260-B	

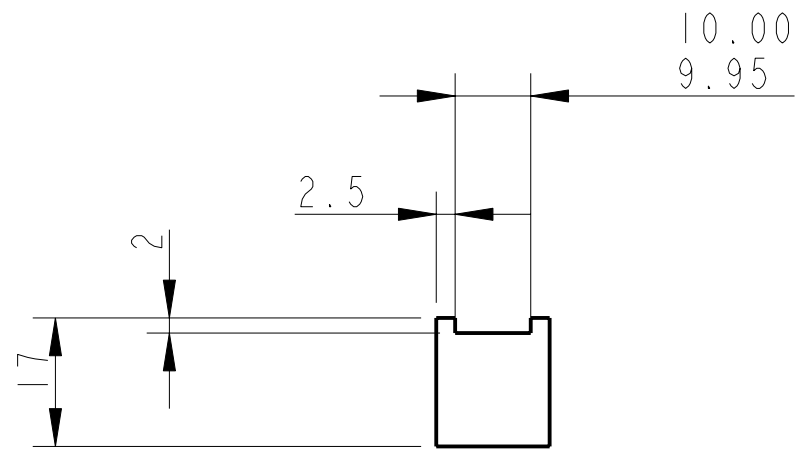

SECTION A-A

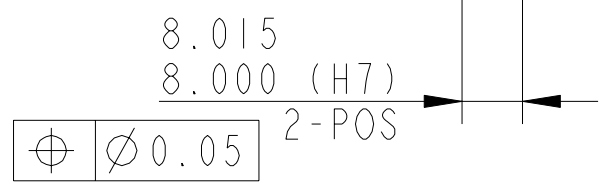
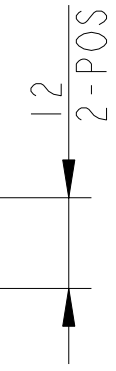
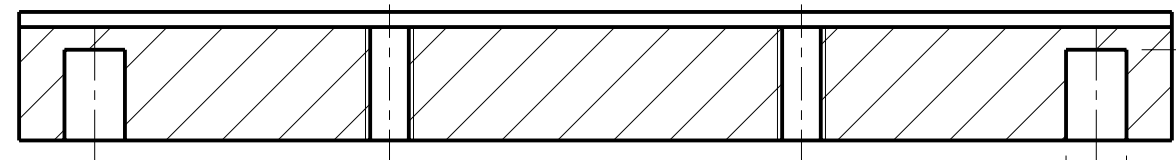

TAP 2 HOLES 1/4-20 UNC X 0.005" OVERSIZE THRO

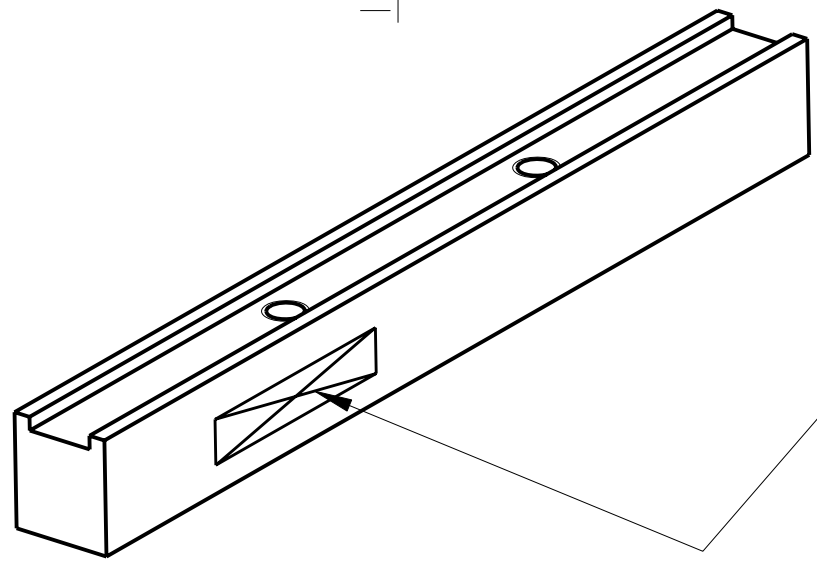
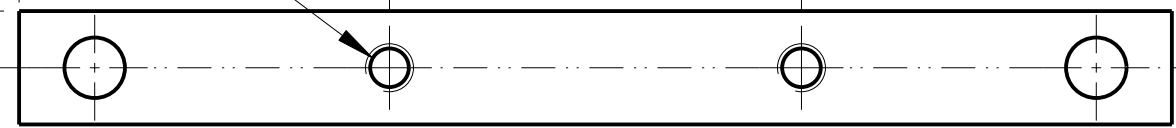
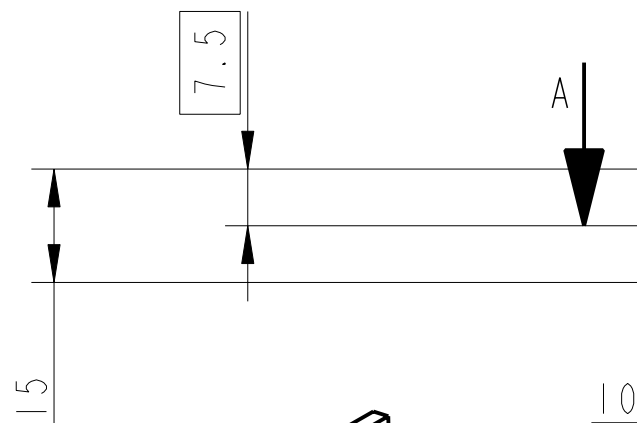
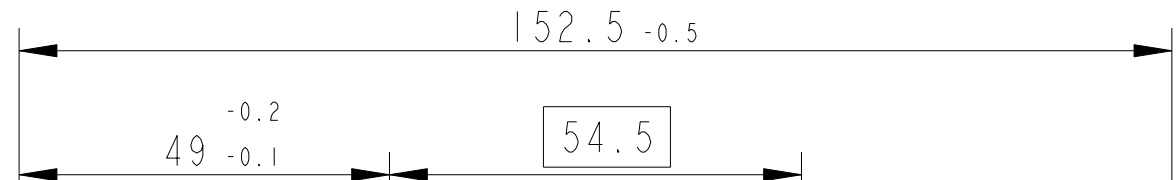
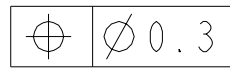

PART NO. (SEE NOTE 4) TO BE ETCHED OR STAMPED IN APPROX POSITION SHOWN.

NOTES: (UNLESS OTHERWISE SPECIFIED)

- REMOVE ALL SHARP EDGES, R.02 MIN.
- DO NOT SCALE FROM DRAWING.
- ALL MACHINING FLUIDS SHALL BE WATER SOLUBLE AND FREE OF SULFUR, CHLORINE AND SILICONE, SUCH AS CINCINNATI MILACRON'S CIMTECH 410 (STAINLESS STEEL)
- SCRIBE, ENGRAVE OR STAMP DRAWING PARTNUMBER ON NOTED SURFACE OF PART AND A THREE DIGIT SERIAL NUMBER. SERIAL NUMBERS START AT 001 FOR THE FIRST PART AND PROCEED CONSECUTIVELY. USE .07" HIGH CHARACTERS. EXAMPLE: D020188- 001. A VIBRATORY TOOL MAY BE USED.

DIMENSIONS ARE IN mm [INCHES]	
TOLERANCES:	
X.XX ±0.2 mm	
ANGULAR ±0.25 °	
MATERIAL:	AL. ALLOY 5083 H4 OR 6061
FINISH:	CLEAN
√μm [μin]	Ra = 1.6
DRAWN	NJS/FEL 1/AUG/06
CHECKED	J'OD --/--/--
APPROVED	IW --/--/--

CALIFORNIA INSTITUTE OF TECHNOLOGY MASSACHUSETTS INSTITUTE OF TECHNOLOGY IGR, GLASGOW UNIVERSITY GEO 600 GROUP RUTHERFORD APPLETON LABORATORIES	
SYSTEM	ADVANCED LIGO
SUB-SYSTEM	SUS
NEXT ASSY	QUAD N-PTYPE LOWER STRUCTURE
PART NAME	ADJUSTABLE PAD JAW ADJUSTABLE PAD ASSY (LONG)
SIZE	B
DRG. NO.	D060447
SCALE	1:1
PROJECTION	
SHEET	1 OF 1