

REV.	DATE	DCN #	DRAWING TREE #
A	15/OCT/06	E060240	

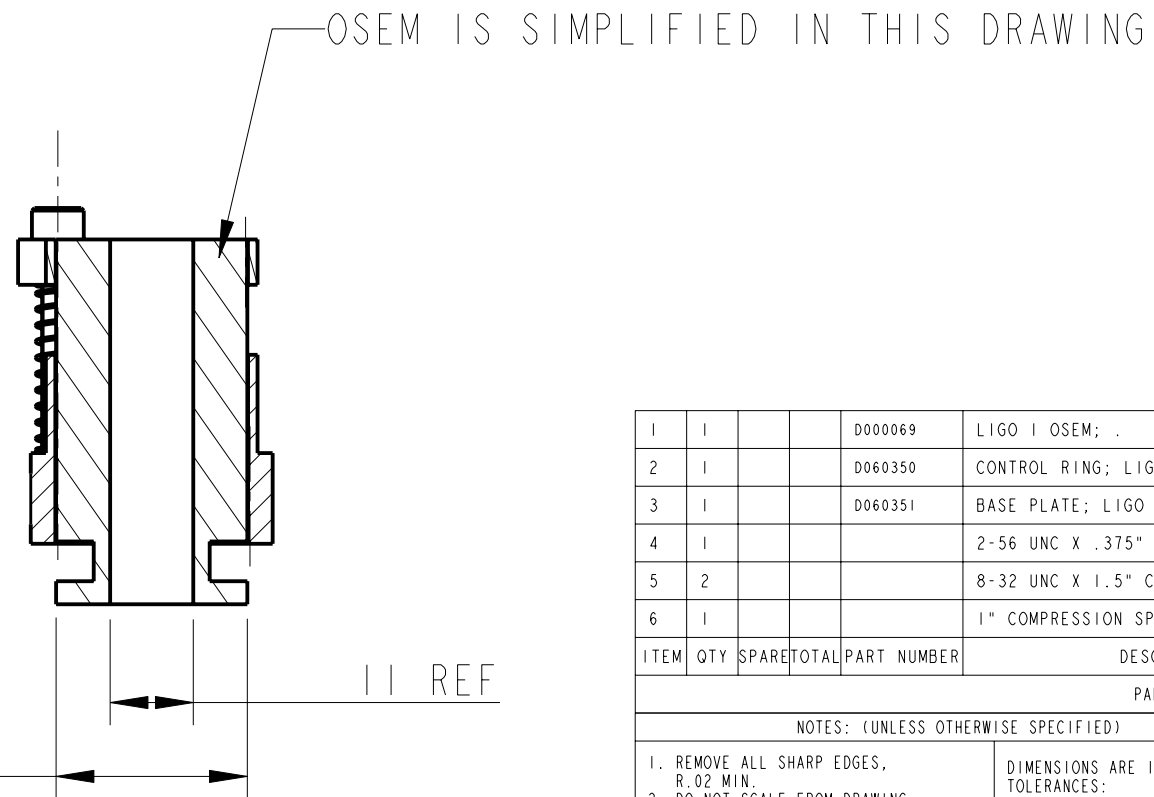
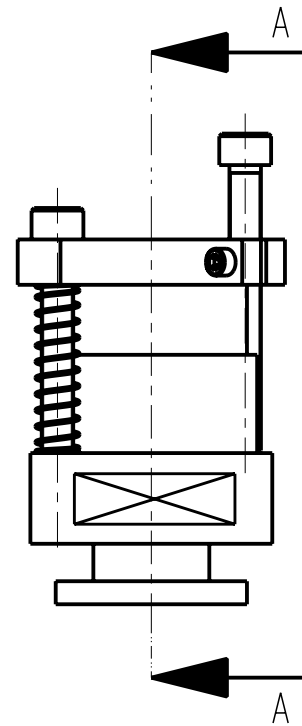
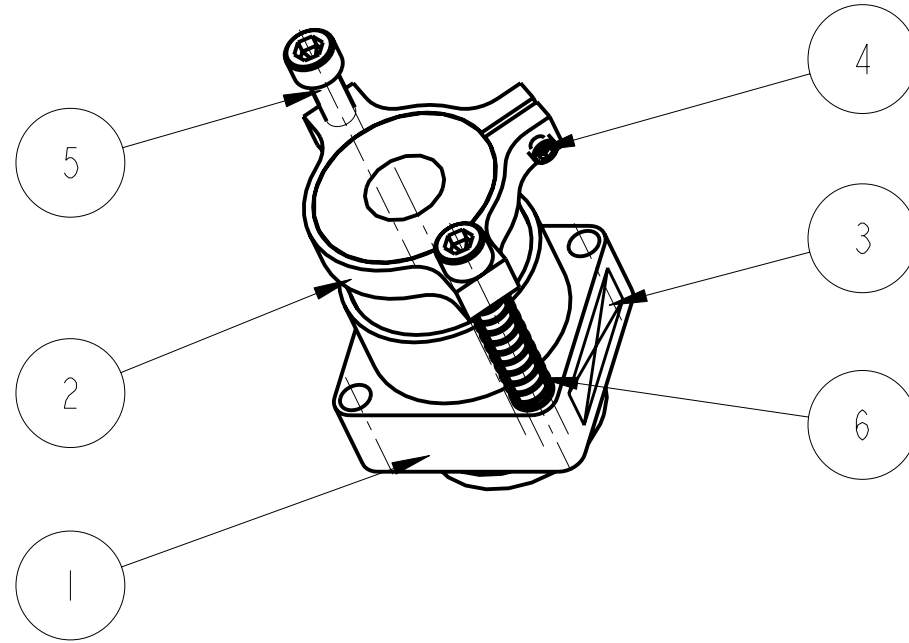
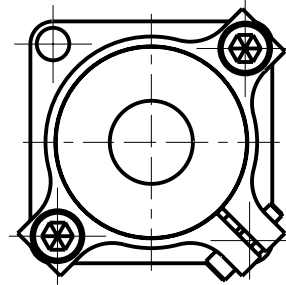

ITEM	QTY	SPARE	TOTAL	PART NUMBER	DESCRIPTION	MATERIALS
1	1			D000069	LIGO 1 OSEM; .	-----; -----
2	1			D060350	CONTROL RING; LIGO 1 OSEM MOUNT	AL ALLOY: 5083
3	1			D060351	BASE PLATE; LIGO 1 OSEM MOUNT	AL ALLOY: 5083
4	1				2-56 UNC X .375" CAP HEAD; .	
5	2				8-32 UNC X 1.5" CAP HEAD; .	ST STEEL: 300 SERIES
6	1				1" COMPRESSION SPRING; 1" FREE LENGTH	

PARTS LIST

NOTES: (UNLESS OTHERWISE SPECIFIED)

- REMOVE ALL SHARP EDGES, R.02 MIN.
- DO NOT SCALE FROM DRAWING.
- ALL MACHINING FLUIDS SHALL BE WATER SOLUBLE AND FREE OF SULFUR, CHLORINE AND SILICONE, SUCH AS CINCINNATI MILACRON'S CIMTECH 410 (STAINLESS STEEL)
- SCRIBE, ENGRAVE OR STAMP DRAWING PART NUMBER ON NOTED SURFACE OF PART AND A THREE DIGIT SERIAL NUMBER. SERIAL NUMBERS START AT 001 FOR THE FIRST PART AND PROCEED CONSECUTIVELY. USE .07" HIGH CHARACTERS. EXAMPLE: D020188- 001. A VIBRATORY TOOL MAY BE USED.

DIMENSIONS ARE IN INCHES (mm)
TOLERANCES:
XX ±0.2 mm
ANGULAR ± 0.5 °

MATERIAL: AS DRW

FINISH:
√μm [μin] Ra = -----

NAME	DATE
DRAWN J O'DELL	20/SEP/06
CHECKED IW	28/SEP/06
APPROVED IW	28/SEP/06

CALIFORNIA INSTITUTE OF TECHNOLOGY
MASSACHUSETTS INSTITUTE OF TECHNOLOGY
IGR, GLASGOW UNIVERSITY GEO 600 GROUP
RUTHERFORD APPLETON LABORATORIES

SYSTEM **ADVANCED LIGO**

SUB-SYSTEM **SUS**

NEXT ASSY **N-PTYPE PENULTIMATE MASS**

PART NAME **LIGO 1 OSEM MOUNT**
(FOR PENRE MASS)

SIZE **B** DRG. NO. **D060349** REV **D.**

SCALE 1:1 PROJECTION: SHEET 1 OF 1

SECTION A-A