

4

3

2

1

REV.	DATE	DCN #	DRAWING TREE #
v1	02 AUG 2009	E0900225	E080191
-	-	-	-
-	-	-	-

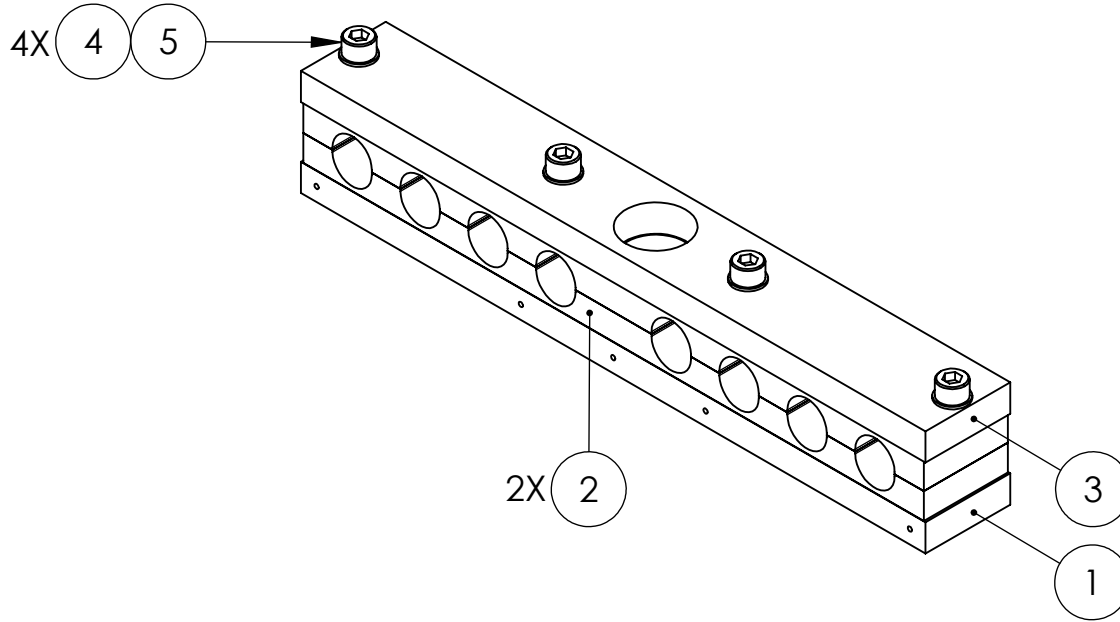

5	-	SCREW, SOCKET HEAD CAP, #4-40 UNC-2A X 0.75 LONG	300 SSTL	4	1	5
4	-	WASHER, FLAT, #4 (NAS 620-C4L OR EQUIVALENT)	300 SSTL	4	1	5
3	D0901547	TOP PLATE	6061-T6 Al	1	0	1
2	D0901544	CABLE CLAMP LINER	FLUROELASTOMER	2	0	2
1	D0901545	BASE PLATE	6061-T6 Al	1	0	1
ITEM NO.	PART NUMBER	DESCRIPTION	MATERIAL	REQ	SPARE	TOTAL

PARTS LIST

NOTES AND TOLERANCES: (UNLESS OTHERWISE SPECIFIED)



CALIFORNIA INSTITUTE OF TECHNOLOGY
MASSACHUSETTS INSTITUTE OF TECHNOLOGY

SYSTEM ADVANCED LIGO SUB-SYSTEM SUS

NEXT ASSY MULTIPLE ASSYS

PART NAME

40-METER CABLE CLAMP

DESIGNER	D. BRIDGES	02 AUG 2009	SIZE	DWG. NO.	REV.
DRAFTER	D. BRIDGES	02 AUG 2009	A	D010120	v1
CHECKER	M. MEYER	03 AUG 2009			
APPROVAL			SCALE: 1:1	PROJECTION:	SHEET 1 OF 1

4

3

2

1