

4

3

2

1

NOTES CONTINUED:

5 SCRIBE, ENGRAVE, OR MECHANICALLY STAMP (NO INKS OR DYES) DRAWING PART NUMBER AND REVISION ON NOTED SURFACE FOLLOWED ON THE NEXT LINE BY A THREE DIGIT SERIAL NUMBER. SERIAL NUMBERS START AT 001 FOR THE FIRST ARTICLE AND PROCEED CONSECUTIVELY. USE .07" HIGH CHARACTERS. EXAMPLE: DXXXXXX-VY, S/N 001. A VIBRATORY TOOL MAY BE USED.

REV.	DATE	DCN #	DRAWING TREE #
v1	31 JUL 2009	E0900172	E0900242
v2	15 OCT 2009	E0900346	-
-	-	-	-

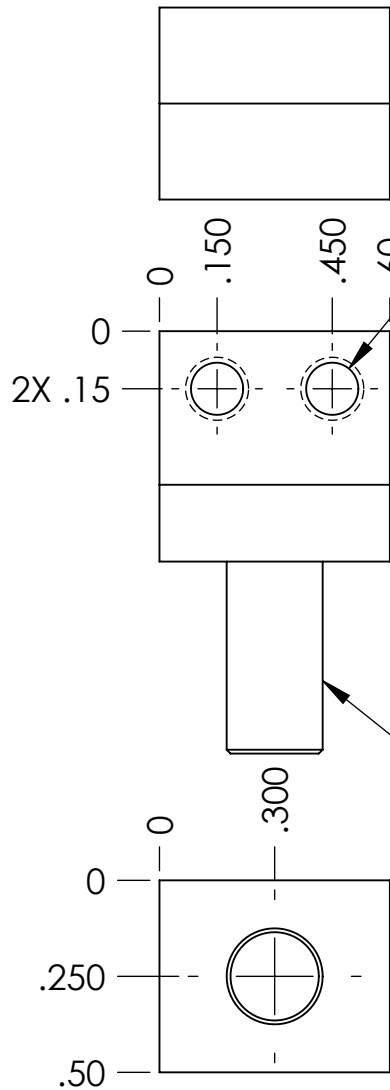

2X #8-32 UNC THRU ALL
+.005 OVERSIZE TAP

1/4-28 UNC THREAD

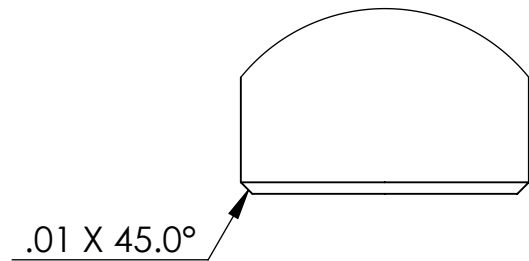
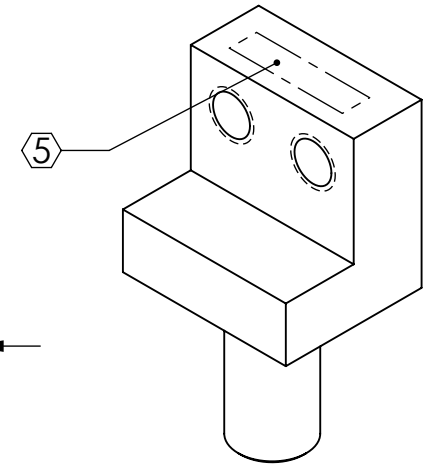
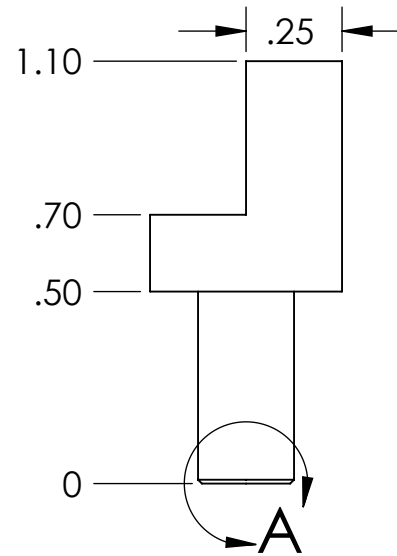

DETAIL A
SCALE 6:1

NOTES AND TOLERANCES: (UNLESS OTHERWISE SPECIFIED)

DIMENSIONS ARE IN INCHES

TOLERANCES:
.XX ± .01
.XXX ± .005

ANGULAR ± 0.5°

1. INTERPRET DRAWING PER ASME Y14.5-1994.
2. REMOVE ALL SHARP EDGES, R.02 MIN.
3. DO NOT SCALE FROM DRAWING.
4. ALL MACHINING FLUIDS SHALL BE WATER SOLUBLE AND FREE OF SULFUR, CHLORINE AND SILICONE, SUCH AS CINCINNATI MILACRON'S CIMTECH 410.

MATERIAL 304, 316 OR 302 SSSL	FINISH 63 μinch
---	---------------------------

LIGO CALIFORNIA INSTITUTE OF TECHNOLOGY
MASSACHUSETTS INSTITUTE OF TECHNOLOGY

SYSTEM ADVANCED LIGO	SUB-SYSTEM SUS
NEXT ASSY D0901298	

PART NAME WIRE CLAMP BOLT			DESIGNER R. GIGLIO 23 JUN 2009		SIZE A	DWG. NO. D0901296	REV. v2
DRAFTER W. RASCH 31 JUL 2009			CHECKER M. MEYER 31 JUL 2009		APPROVAL	SCALE: 2:1	PROJECTION:
SHEET 1 OF 1							