

NOTES CONTINUED:
 5. VENDOR REFERENCES ARE PROVIDED AS EXAMPLES OF PARTS MEETING ALL REQUIRED SPECIFICATIONS. EQUIVALENTS ARE ALWAYS ACCEPTABLE UNLESS OTHERWISE SPECIFIED.
 6. ELECTRONIC COMPONENTS IN MODELS AND BOMS ARE FOR LAYOUT AND ASSEMBLY PURPOSES ONLY AND NOT TO BE USED FOR PURCHASING.
 7. ASSEMBLY PROCEDURE: E0900357 AND E1000096.

REV.	DATE	DCN #	DRAWING TREE #
v1	22 Feb. 2010	E1000049	E1000025
v2	24 Aug 2010	E1000353	E1000025

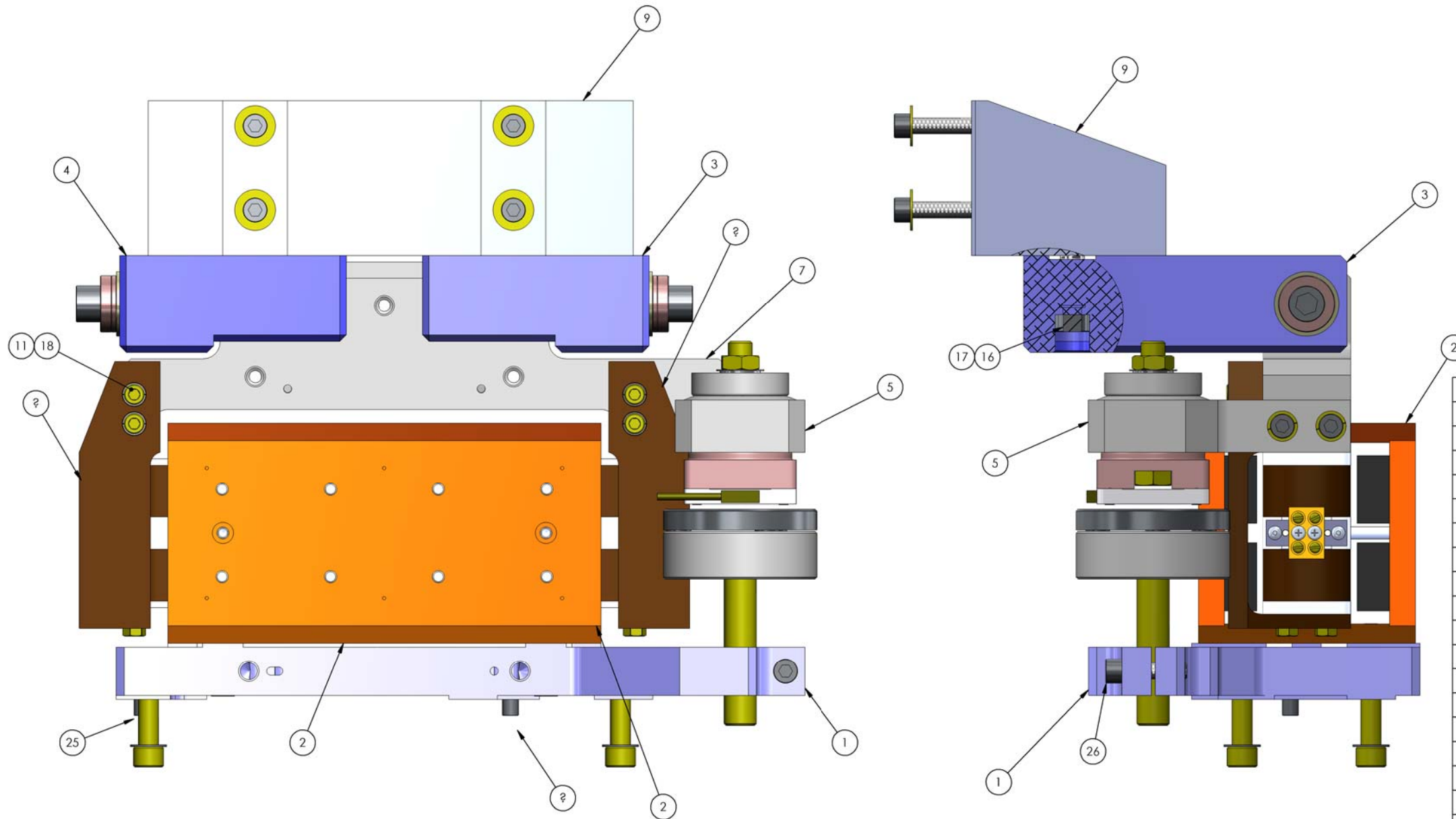

ITEM NO.	PART NUMBER	DESCRIPTION	MATERIAL	Running Config/QTY.
27	D1002282	STEP PIN, LARGE ACTUATOR, aLIGO BSC ISI	18-8 SS	2
26	HOLOKROME_78062	SHCS, 1/4"-20x1.0"	18-8 SS	1
25	McMASTER_90145A539	Dowel Pin 1/4" (.2501) x 5/8" L 18.8 SST	18-8 Stainless	2
24	McMASTER_90145A470	Dowel Pin	18-8 SS	2
23	McMASTER_91944A450	Spherical Washer .406 id x .88 od x .25 thk	18-8 SSSL	4
22	McMASTER_92141A051	Flat Washer, 3/8"	18-8 SS	4
21	McMASTER_92196A636	SHCS, 3/8"-16x3.0"	18-8 SS	2
20	McMASTER_92196A584	Screw, SHCS, 5/16-18 x 1 1/8 lg.	18-8 SSSL	4
19	UC_COMPONENTS_WFV-31	Washer Vented, .328 ID X .562 OD X .032 THK #5/16	18-8 SSSL	4
18	McMASTER_92196A271	Screw 10-32 x .62 lg.	18-8 SSSL	4
17	UC_COMPONENTS_WFV-38	Washer Vented, .39 ID X .63 OD X .032 THK #3/8"	18-8 SS	4
16	HOLOKROME_78104	SHCS, 3/8"-16x1.75"	18-8 SS	4
15	HOLOKROME_78060	SHCS, 1/4"-20x.875"	18-8 SS	4
14	McMASTER_98019A355	WASHER .28 ID X .63 OD X .065 THK	300 SSSL	8
13	HOLOKROME_78066	SHCS	18-8 SS	4
12	McMASTER_92196A291	Screw SHCS, 10-32 x 1.375 lg.	18-8 SSSL	4
11	UC_COMPONENTS_WFV-10	Washer Vented, 0.195 ID, 0.354 OD, 0.032 THK #10	18-8 SS	8
10	UC_COMPONENTS_H-1006	Hex Head Machine Screw, 10-32 x 3/8 lg vented	18-8 SSSL	4
9	D0901183	LARGE VERT. ACTUATOR POST BRIDGE, STAGE 0-1, aLIGO BSC ISI	6061-T6 Al	1
8	D1000175	THERMAL BAR, LEFT, LARGE ACTUATOR, aLIGO BSC ISI	COPPER	1
7	D0902426	Large Vert. Actuator Coll Bracket, Stage 0-1, aLIGO BSC ISI	6061-T6 Al	1
6	D1000176	THERMAL BAR, RIGHT, LARGE ACTUATOR, aLIGO BSC ISI	COPPER	1
5	D1000477	SENSOR ASSEMBLY VERTICAL, aLIGO BSC ISI	N/A	1
4	D0902422	LARGE VERT. ACTUATOR CONNECTOR RIGHT, STAGE 0-1, aLIGO BSC ISI	6061-T6 Al	1
3	D0902428	LARGE VERT. ACTUATOR CONNECTOR LEFT, STAGE 0-1, aLIGO BSC ISI	6061-T6 Al	1
2	D0902749	Large Actuator, aLIGO SEI HAM-ISI & BSC-ISI	N/A	1
1	D0902310	ACTUATOR MAGNET BRACKET, STAGE 0-1, aLIGO BSC ISI	6061-T6 Al	1

NOTES AND TOLERANCES: (UNLESS OTHERWISE SPECIFIED)	
1. INTERPRET DRAWING PER ASME Y14.5-1994.	
2. REMOVE ALL SHARP EDGES, R.02 MIN.	
3. DO NOT SCALE FROM DRAWING.	
4. ALL MACHINING FLUIDS MUST BE FULLY SYNTHETIC, FULLY WATER SOLUBLE AND FREE OF SULFUR, SILICONE, AND CHLORINE.	
DIMENSIONS ARE IN INCHES	
TOLERANCES: .XX ± N/A .XXX ± N/A	
ANGULAR ± N/A *	
MATERIAL	N/A
FINISH	- μinch

CALIFORNIA INSTITUTE OF TECHNOLOGY MASSACHUSETTS INSTITUTE OF TECHNOLOGY		PART NAME LARGE VERTICAL ACTUATOR ASSY, STAGE 0-1, aLIGO BSC ISI	
SYSTEM	ADVANCED LIGO	SUB-SYSTEM	SEI
NEXT ASSY	D1000289	DESIGNER	S.BARNUM 22 Feb. 2010
		DRAFTER	M.HILLARD 22 Feb. 2010
		CHECKER	F.MATICHARD 22 Feb. 2010
		APPROVAL	K.MASON 22 Feb. 2010
SIZE	D	DWG. NO.	D0901103
REV.	v2	SCALE:	1:1
		PROJECTION:	
		SHEET	1 OF 2

D0901103 Large Vertical Actuator Assy, Stage 0-1, aLIGO BSC ISI, PART PDM REV: K-048, DRAWING PDM REV: K-005

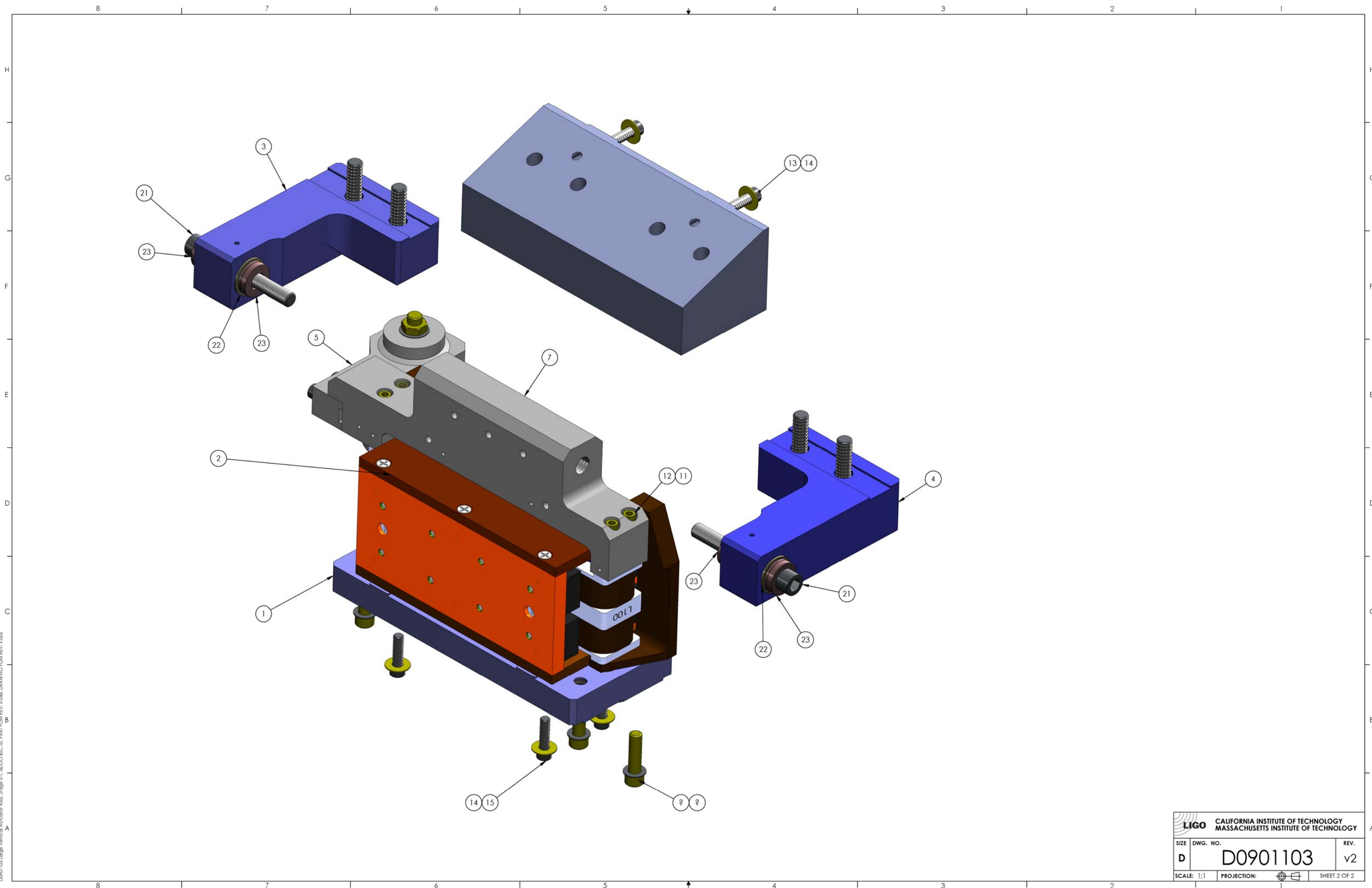

 CALIFORNIA INSTITUTE OF TECHNOLOGY MASSACHUSETTS INSTITUTE OF TECHNOLOGY		
SIZE	DWG. NO.	REV.
D	D0901103	v2
SCALE: 1:1	PROJECTION:	SHEET 2 OF 2

D0901103 Large Vertical Actuator Assy, Stage 0-1, dLGO BCB ISL PART PDM REV: X-048, DRAWING PDM REV: X-005