

NOTES CONTINUED:
 ⑤ SCRIBE, ENGRAVE, OR MECHANICALLY STAMP (NO INKS OR DYES) DRAWING PART NUMBER AND REVISION ON NOTED SURFACE FOLLOWED ON THE NEXT LINE BY A THREE DIGIT SERIAL NUMBER. SERIAL NUMBERS START AT 001 FOR THE FIRST ARTICLE AND PROCEED CONSECUTIVELY. USE .07" HIGH CHARACTERS. EXAMPLE: DXXXXXX-VY, S/N 001. A VIBRATORY TOOL MAY BE USED.

REV.	DATE	DCN #	DRAWING TREE #
-	-	-	-
-	-	-	-
-	-	-	-

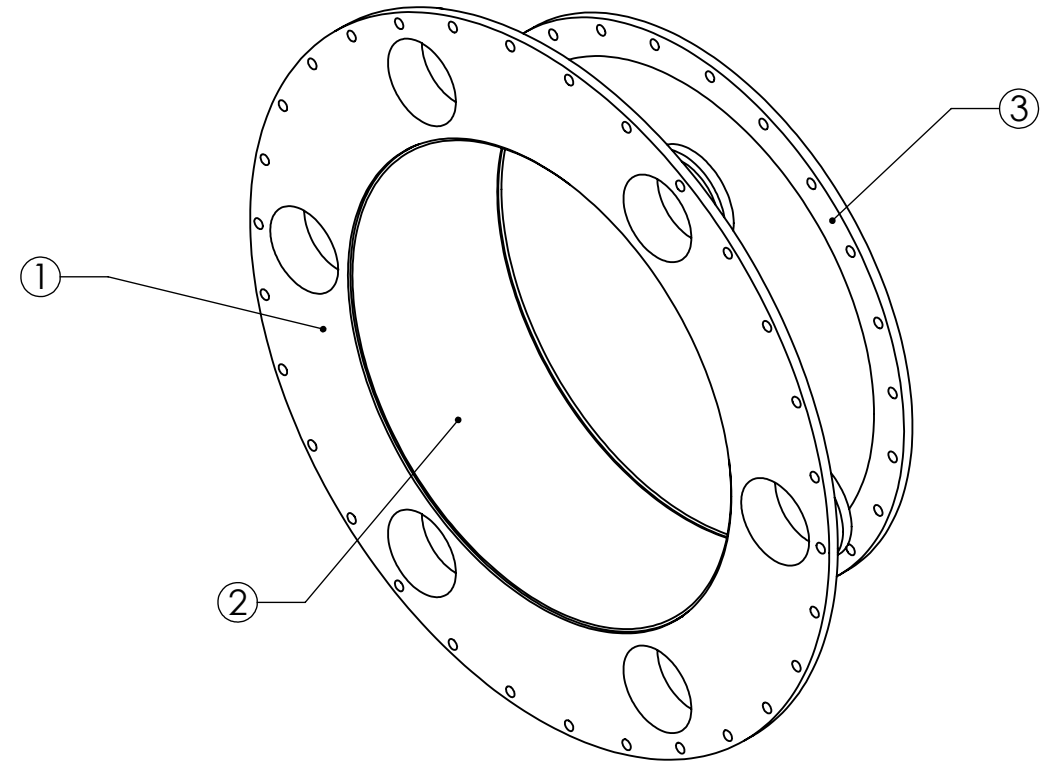
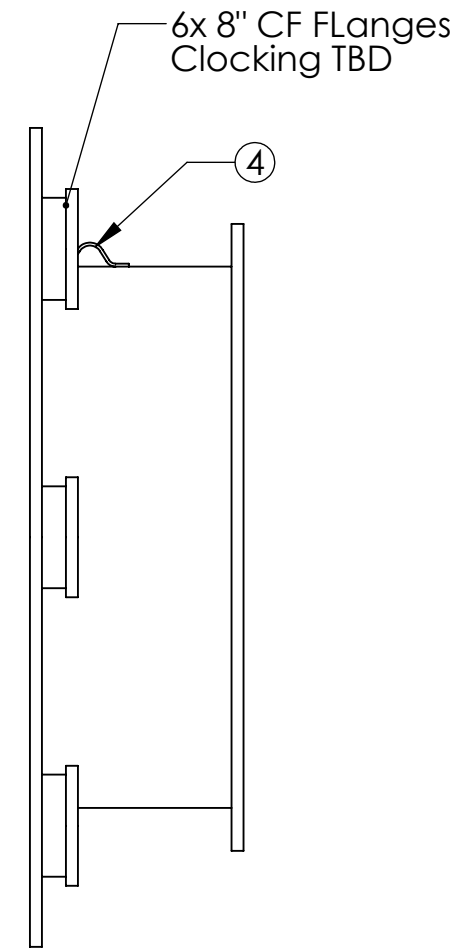
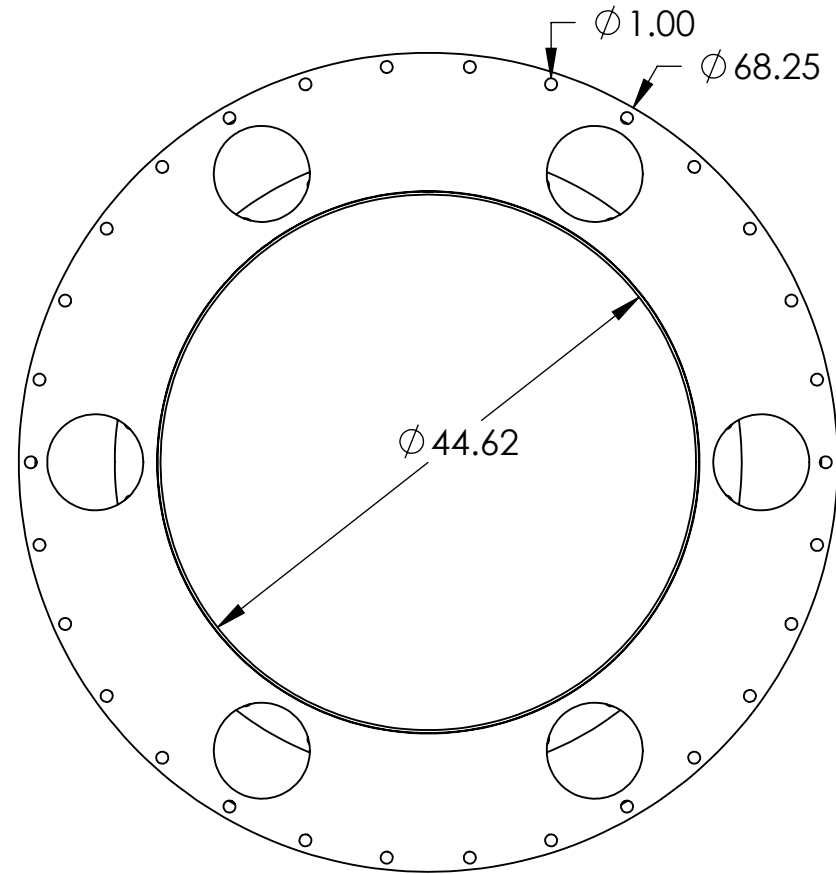
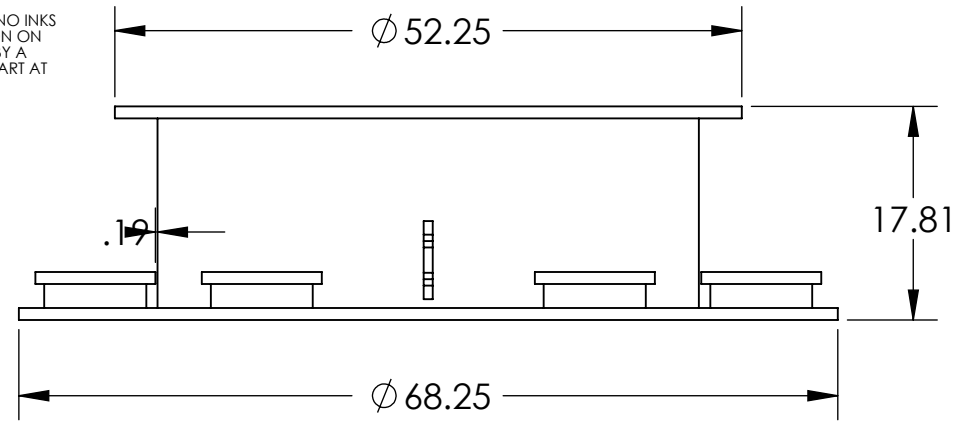

Item #	Part #	Description	Material	Req	Spare	Total
1	D0900961	Flange, Flat Faced, 45.19ID x 68.25OD D961129-01, PSI 049-4-58	AISI 304	1		1
2	D0900962	Cylindrical Shell fo Adapter A-16, 44.625ID, LGO VE	AISI 304	1		1
3	D0900963	Flat Faced Flange, 44.625ID, LIGO VE D961124-01, PSI V049-4-042	AISI 304	1		1
4	D0900964	Lifting Lug, D970446-00, PSI V049-4-159	AISI 304	1		1

NOTES AND TOLERANCES: (UNLESS OTHERWISE SPECIFIED)
 1. REMOVE ALL SHARP EDGES, R.02 MIN.
 2. DO NOT SCALE FROM DRAWING.
 3. DESIGN AND FABRICATE THIS COMPONENT PER LIGO SPECIFICATION E0900411-V1

DIMENSIONS ARE IN
 TOLERANCES:
 .XX ±
 .XXX ±
 ANGULAR ± °

MATERIAL N/A FINISH N/A μinch

LIGO CALIFORNIA INSTITUTE OF TECHNOLOGY MASSACHUSETTS INSTITUTE OF TECHNOLOGY

SYSTEM ADVANCED LIGO SUB-SYSTEM FMP

PART NAME Adapter A-16, 44 1/4" I.D. x 60 1/2" I.D., LIGO VE

DESIGNER Dennis Coyne 12 May 2009 SIZE DWG. NO. B D0900946 REV.

CHECKER APPROVAL

SCALE: 1:16 PROJECTION: SHEET 1 OF 1