

D080001_HAM_Trim_Mass-Large, PART PDM REV: X-002, DRAWING PDM REV: X-000

NOTES CONTINUED:
⑤ SCRIBE, ENGRAVE, OR MECHANICALLY STAMP (NO INKS OR DYES) DRAWING PART NUMBER AND REVISION ON NOTED SURFACE FOLLOWED ON THE NEXT LINE BY A THREE DIGIT SERIAL NUMBER. SERIAL NUMBERS START AT 001 FOR THE FIRST ARTICLE AND PROCEED CONSECUTIVELY. USE .07" HIGH CHARACTERS. EXAMPLE: DXXXXXX-VY, S/N 001. A VIBRATORY TOOL MAY BE USED.

POST-MANUFACTURING NOTES:
P1. CLEAN TO LIGO STANDARDS, CLASS A (PER E0900047 AND E960022).

REV.	DATE	DCN #	DRAWING TREE #
V2	01 May 2009	-	-
-	-	-	-
-	-	-	-

.030 X 45°
AROUND TOP FACE

40X Ø .266 THRU
✓ Ø .30 X 82°, NEAR SIDE

⊕	φ .008 (M)	A	B	C
---	------------	---	---	---

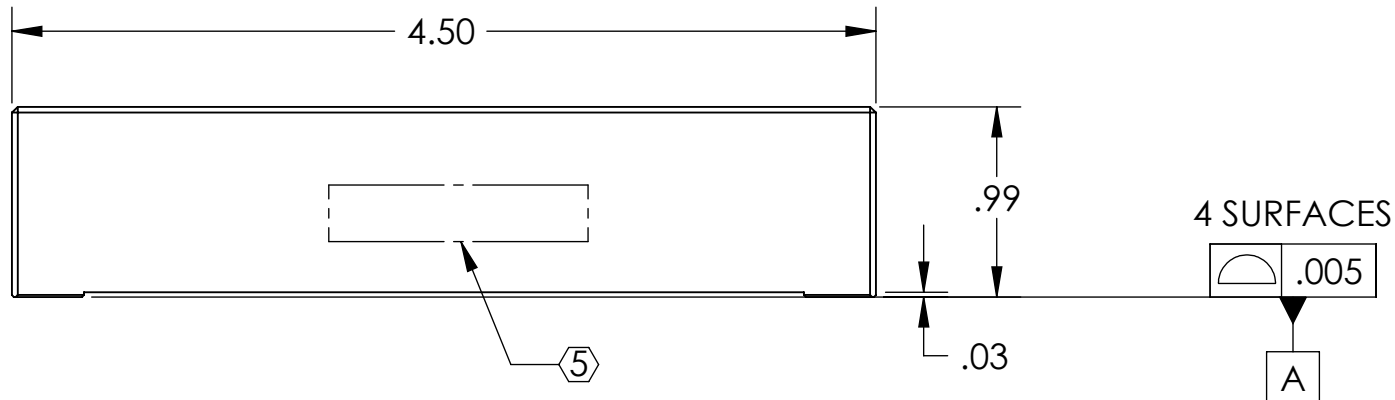
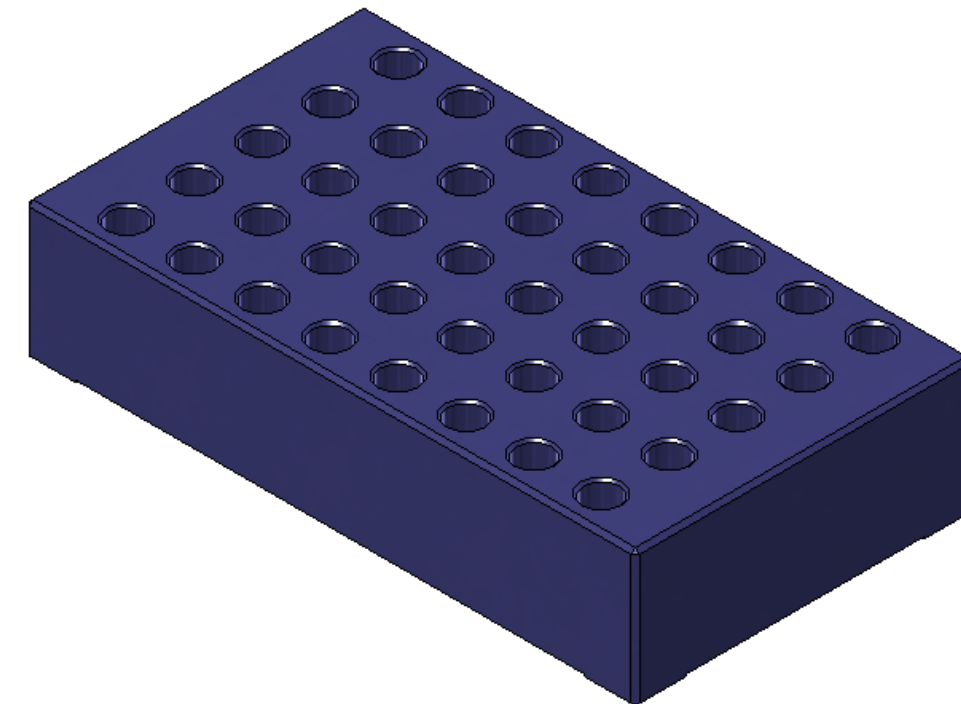
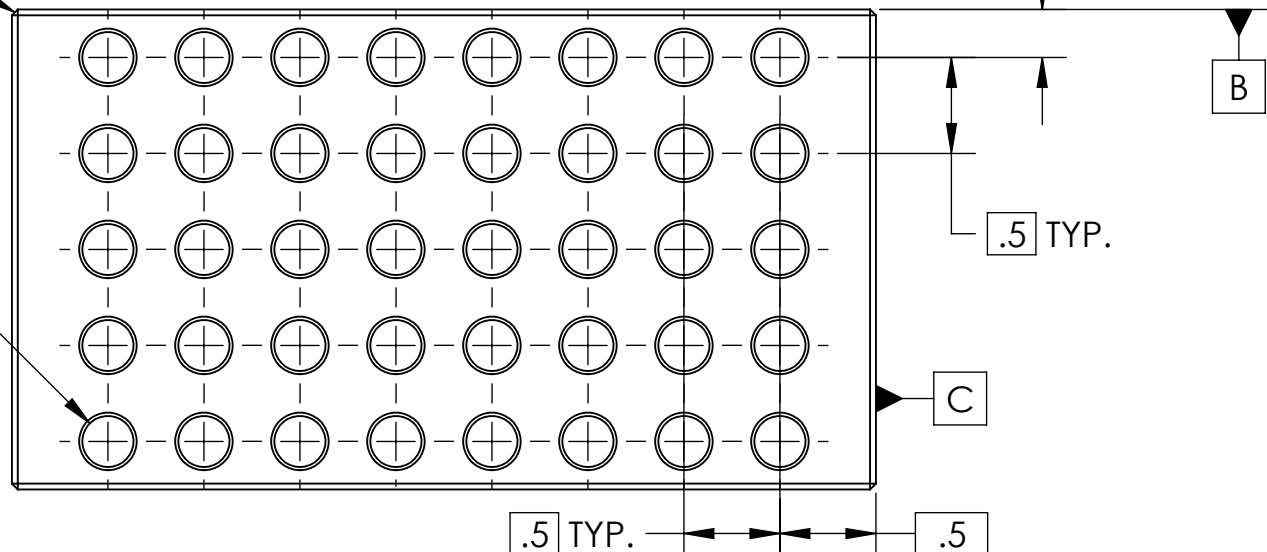

4X .030 X 45°

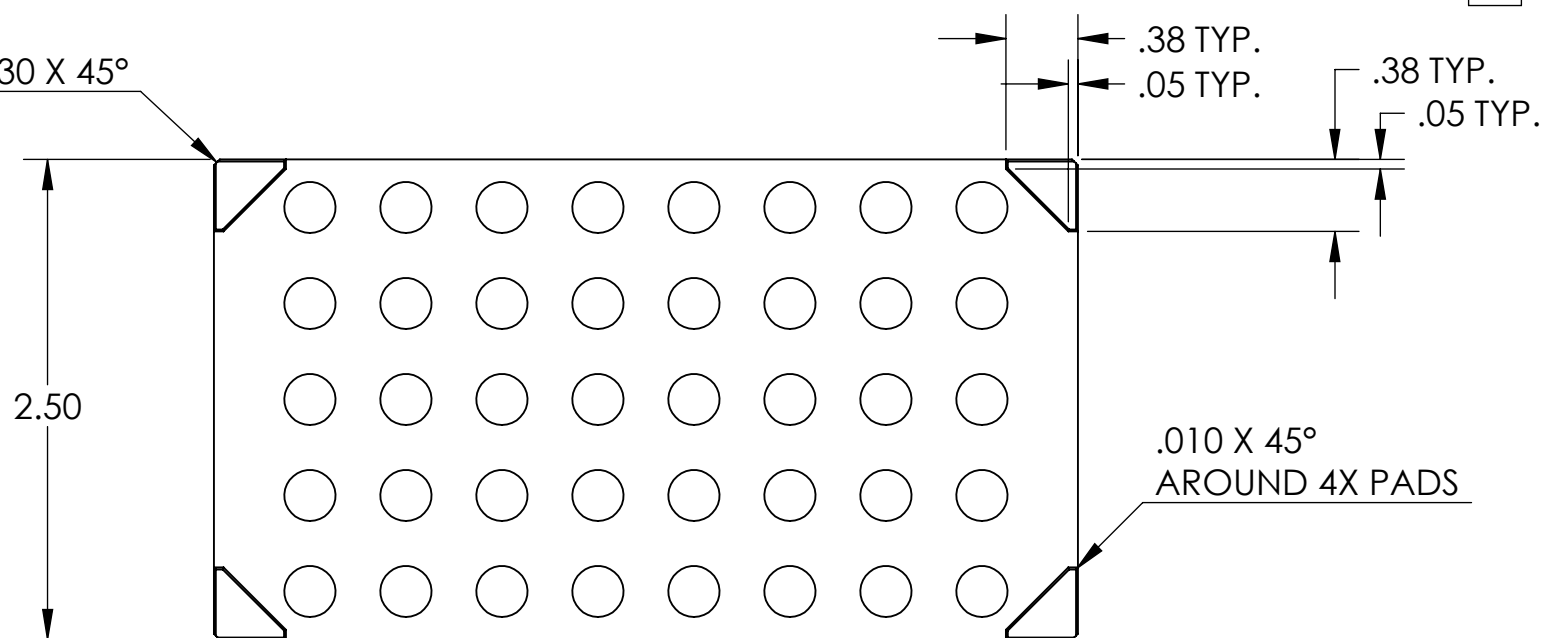

Measured 1.106kg=
2.44lbs

Mass = 1.14 lbs

NOTES AND TOLERANCES: (UNLESS OTHERWISE SPECIFIED)

DIMENSIONS ARE IN INCHES	
TOLERANCES: .XX ± .015 .XXX ± .005	
ANGULAR ± 0.5°	
1. INTERPRET DRAWING PER ASME Y14.5-1994. 2. REMOVE ALL SHARP EDGES, R.02 MIN. 3. DO NOT SCALE FROM DRAWING. 4. ALL MACHINING FLUIDS SHALL BE WATER SOLUBLE AND FREE OF SULFUR, CHLORINE AND SILICONE, SUCH AS CINCINNATI MILACRON'S CIMTECH 410.	
MATERIAL	304 SS
FINISH	63 μinch

 CALIFORNIA INSTITUTE OF TECHNOLOGY MASSACHUSETTS INSTITUTE OF TECHNOLOGY	PART NAME		
	HAM Trim Mass, Large		
	DESIGNER	D. Clark	
	DRAFTER	A. Stein	
SYSTEM	ADVANCED LIGO	SUB-SYSTEM	SEI
NEXT ASSY	D0900124	DESIGNER	D. Clark
		DRAFTER	A. Stein
		CHECKER	
		APPROVAL	A. Stein

SIZE	DWG. NO.	REV.
B	D080001	v2
SCALE:	1:1	PROJECTION:
SHEET 1 OF 1		