

REV.	DATE	DCN #	DRAWING TREE #
v1	24 JUN 2009	E0900176	E080191
v2	05 AUG 2009	E0900232	E080191
v3	02 DEC 2009	E0900446	E080191
v4	18 MAY 2010	E1000166	E080191

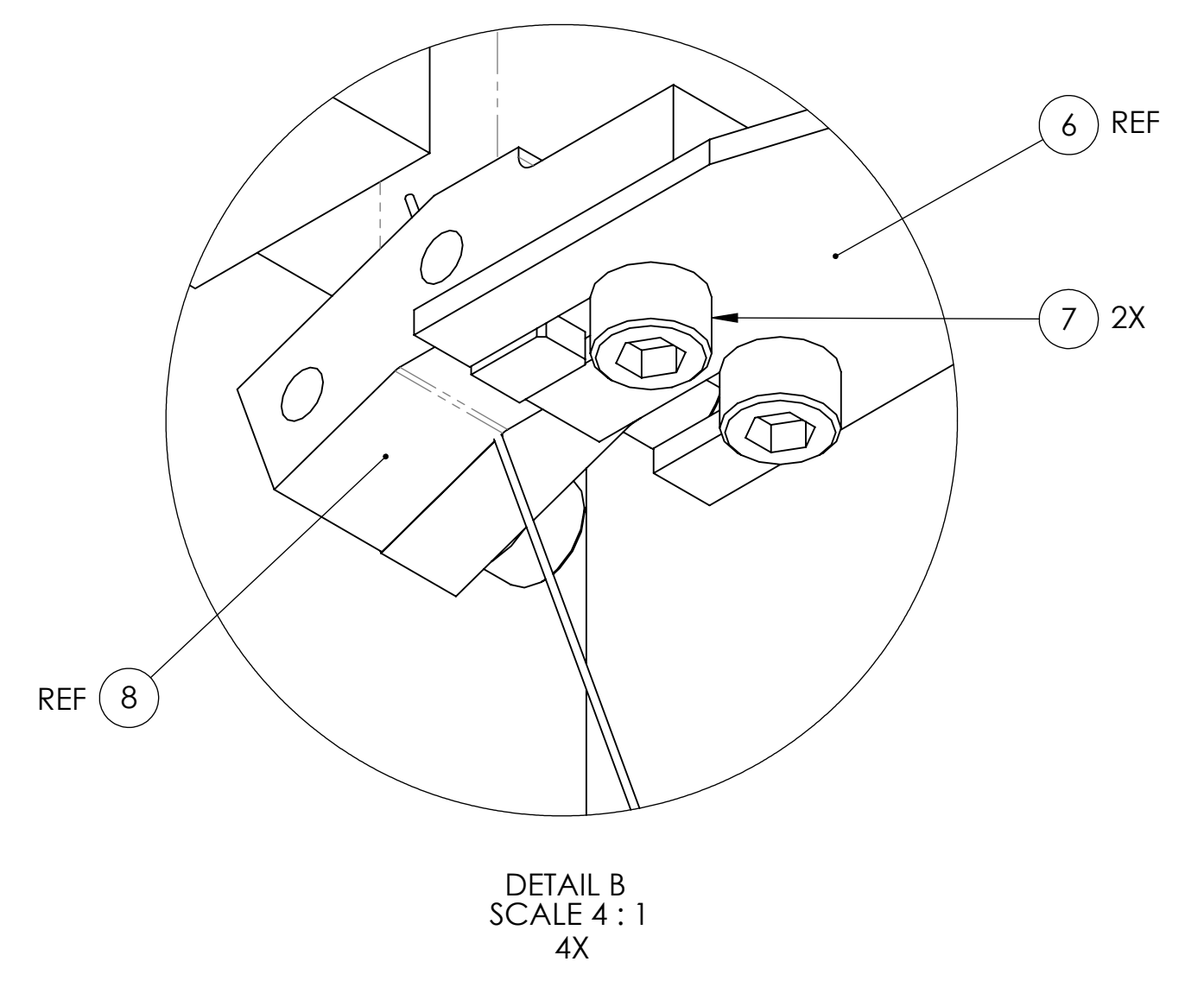
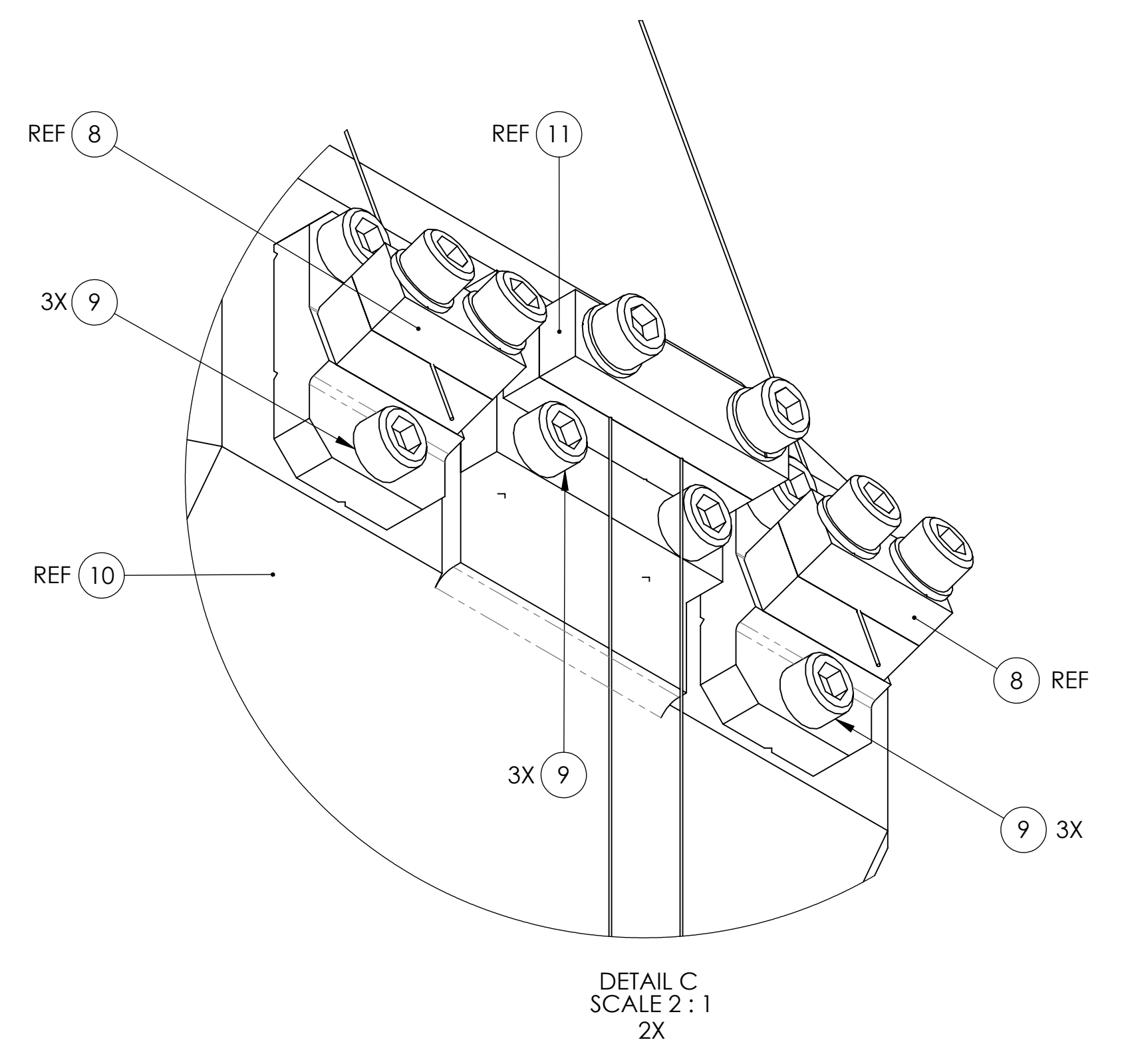
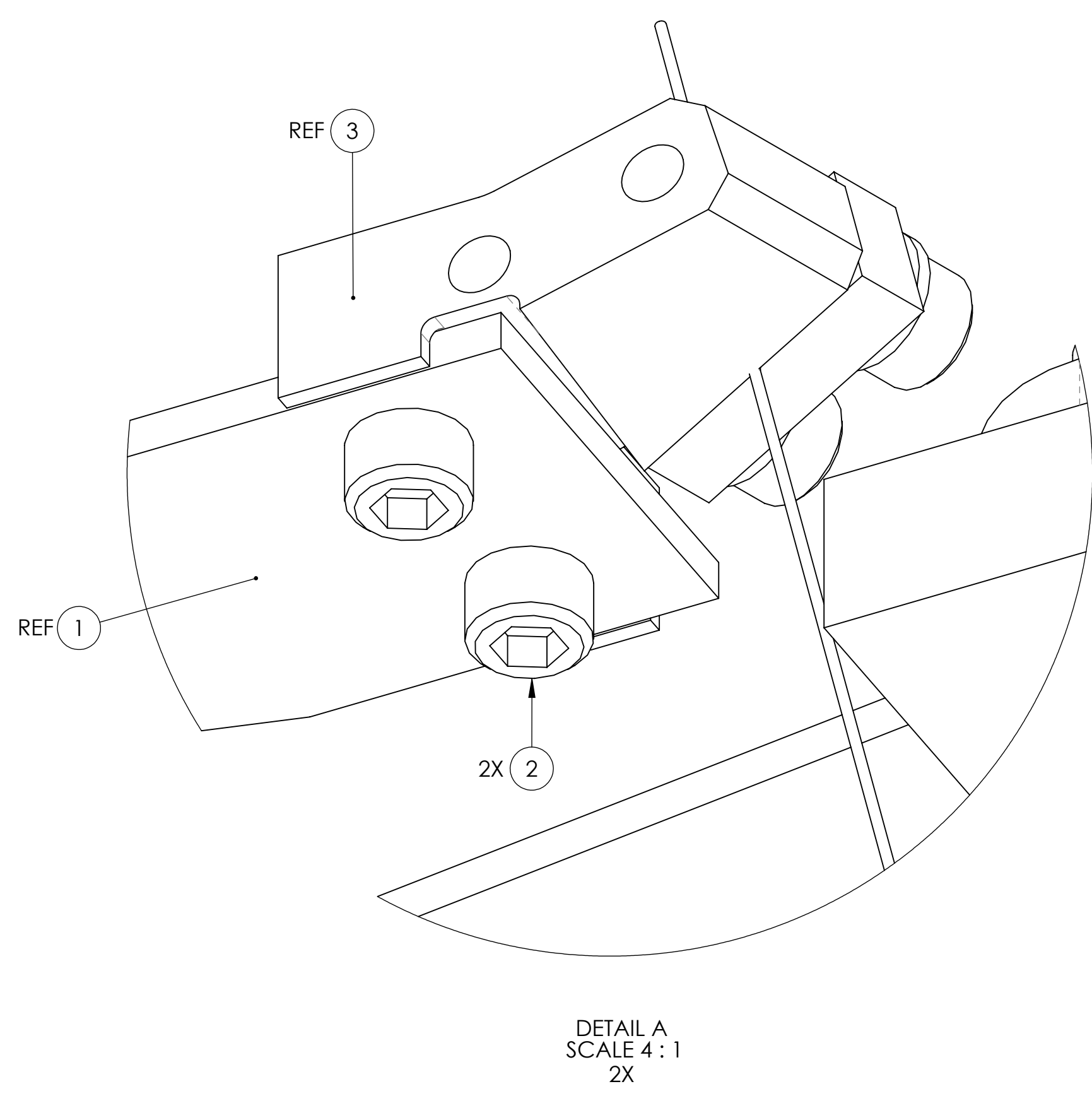
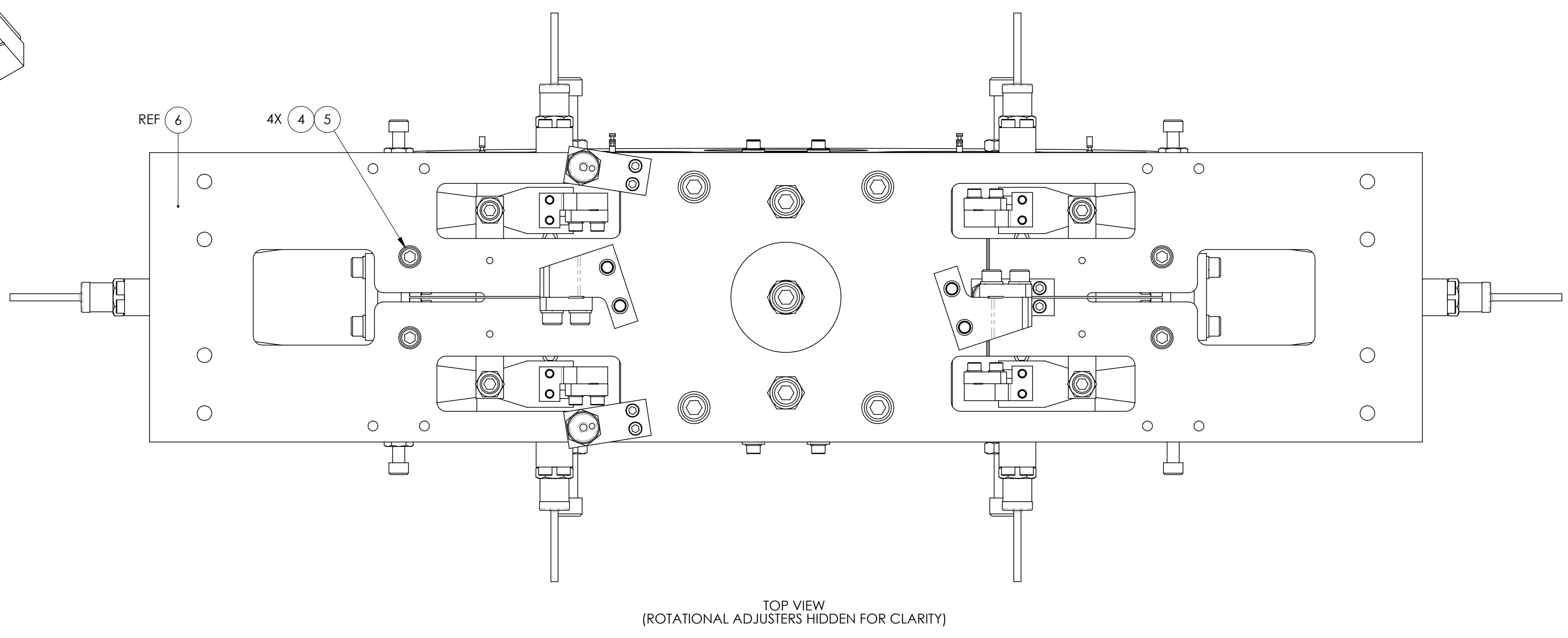
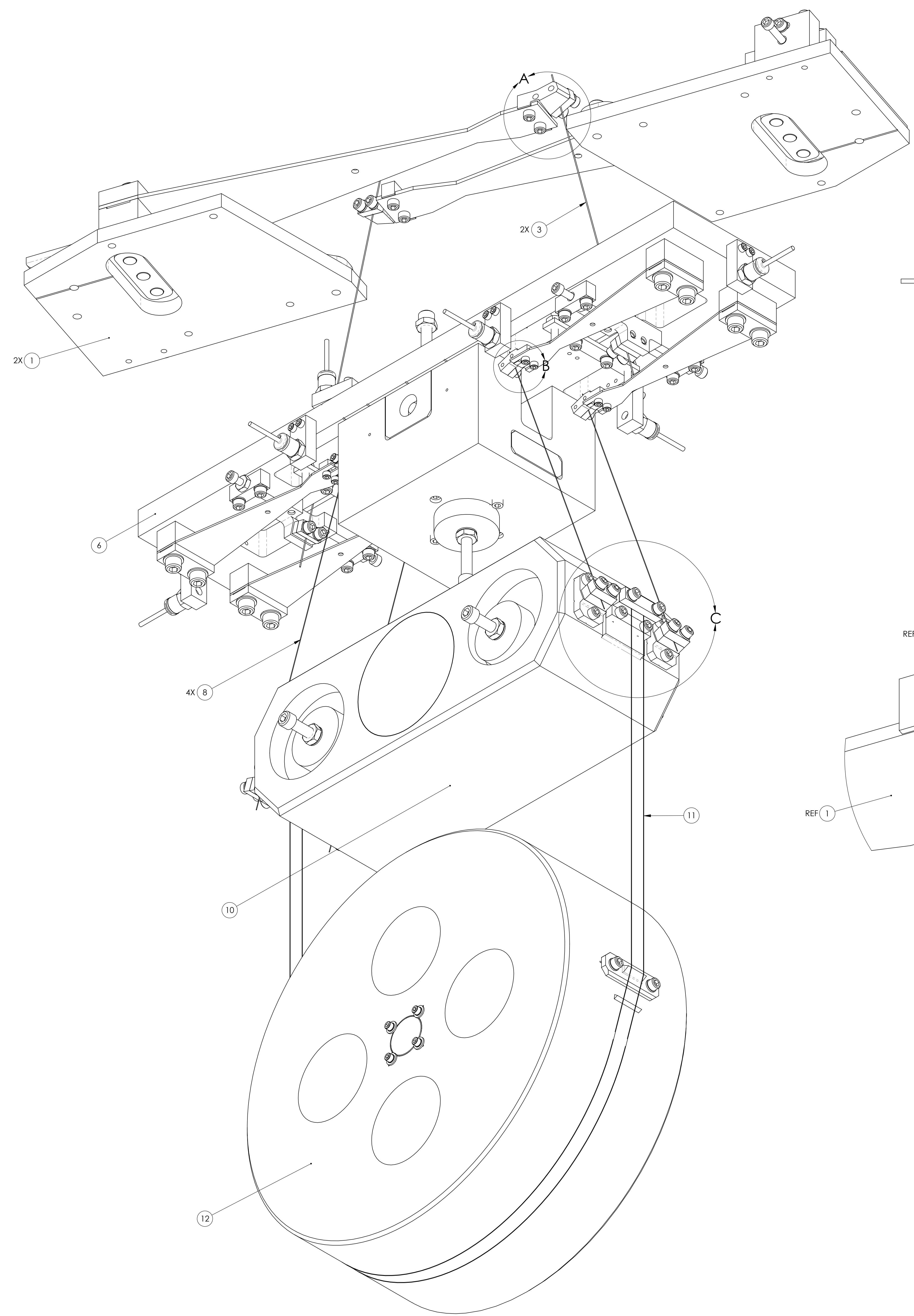

ITEM NO.	PART NUMBER	DESCRIPTION	MATERIAL	REQ	SPARE	TOTAL
12	D070337	BOTTOM MASS ASSY	N/A	1	0	1
11	D070436	LOWER LOOP WIRE ASSY	N/A	1	0	1
10	D070334	INTERMEDIATE MASS ASSY	N/A	1	0	1
9	-	SCREW, SOCKET HEAD CAP, #8-32 UNC-2A X 0.625 LONG	Ag-PLATED 300 SSSTL	18	4	22
8	D070393	INTERMEDIATE WIRE ASSY	N/A	4	0	4
7	-	SCREW, SOCKET HEAD CAP, #4-40 UNC-2A X 0.25 LONG	Ag-PLATED 300 SSSTL	8	2	10
6	D070335	UPPER MASS ASSY	N/A	1	0	1
5	-	SCREW, SOCKET HEAD CAP, #8-32 UNC-2A X 1.125 LONG	300 SSSTL	4	1	5
4	-	WASHER, FLAT, VENTED, #8 (U/C COMPONENTS P/N WFV-08 OR EQUIVALENT)	300 SSSTL	4	1	5
3	D070340	UPPER WIRE ASSY	N/A	2	0	2
2	-	SCREW, SOCKET HEAD CAP, #8-32 UNC-2A X 0.5 LONG	Ag-PLATED 300 SSSTL	4	1	5
1	D070326	ROTATIONAL ADJUSTER	N/A	2	0	2

PARTS LIST

NOTES AND TOLERANCES: (UNLESS OTHERWISE SPECIFIED) 1. PARTS TO BE ASSEMBLED ACCORDING TO E080208 HLTS ASSEMBLY SPECIFICATION.		CALIFORNIA INSTITUTE OF TECHNOLOGY MASSACHUSETTS INSTITUTE OF TECHNOLOGY		PART NAME HLTS SUSPENSION ASSY	
MATERIAL N/A		FINISH N/A μin		SYSTEM ADVANCED LIGO	
NEXT ASSY HLTS OVERALL ASSY		SUB-SYSTEM SUS		DESIGNER D. BRIDGES	
SCALE 1:1		PROJECTION 		SIZE DWG. NO. E D070332	
APPROVAL		CHECKER M. MEYER		REV. v4	

D070332_Rev04.dwg: JACO_SJL:ATE: Suspension: PART FORM REV: V3.00: 18 MAY 2010 15:00:00