

REV.	DATE	DCN #	DRAWING TREE #
v1	24 JUN 2009	E0900176	E080191
-	-	-	-
-	-	-	-

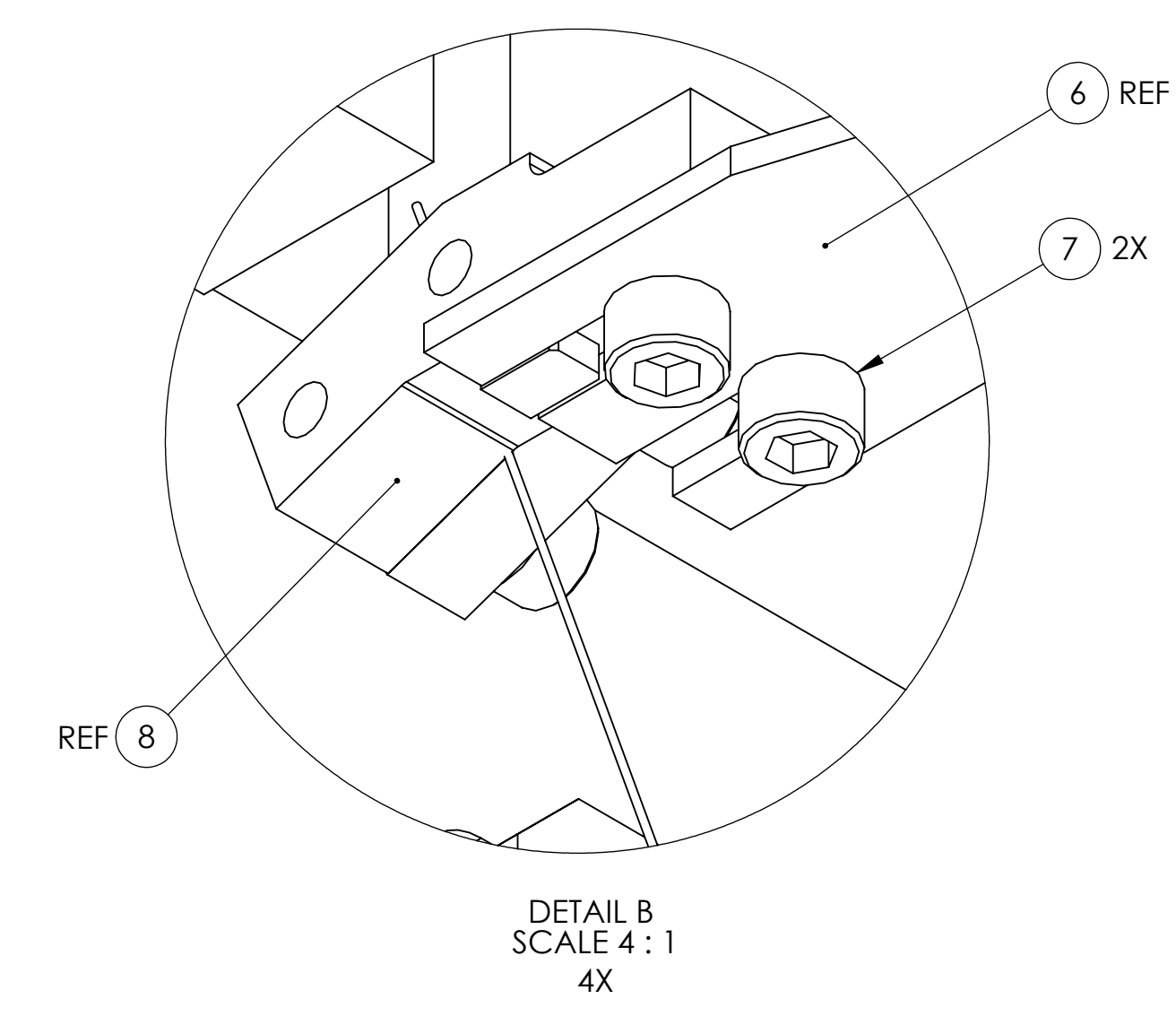
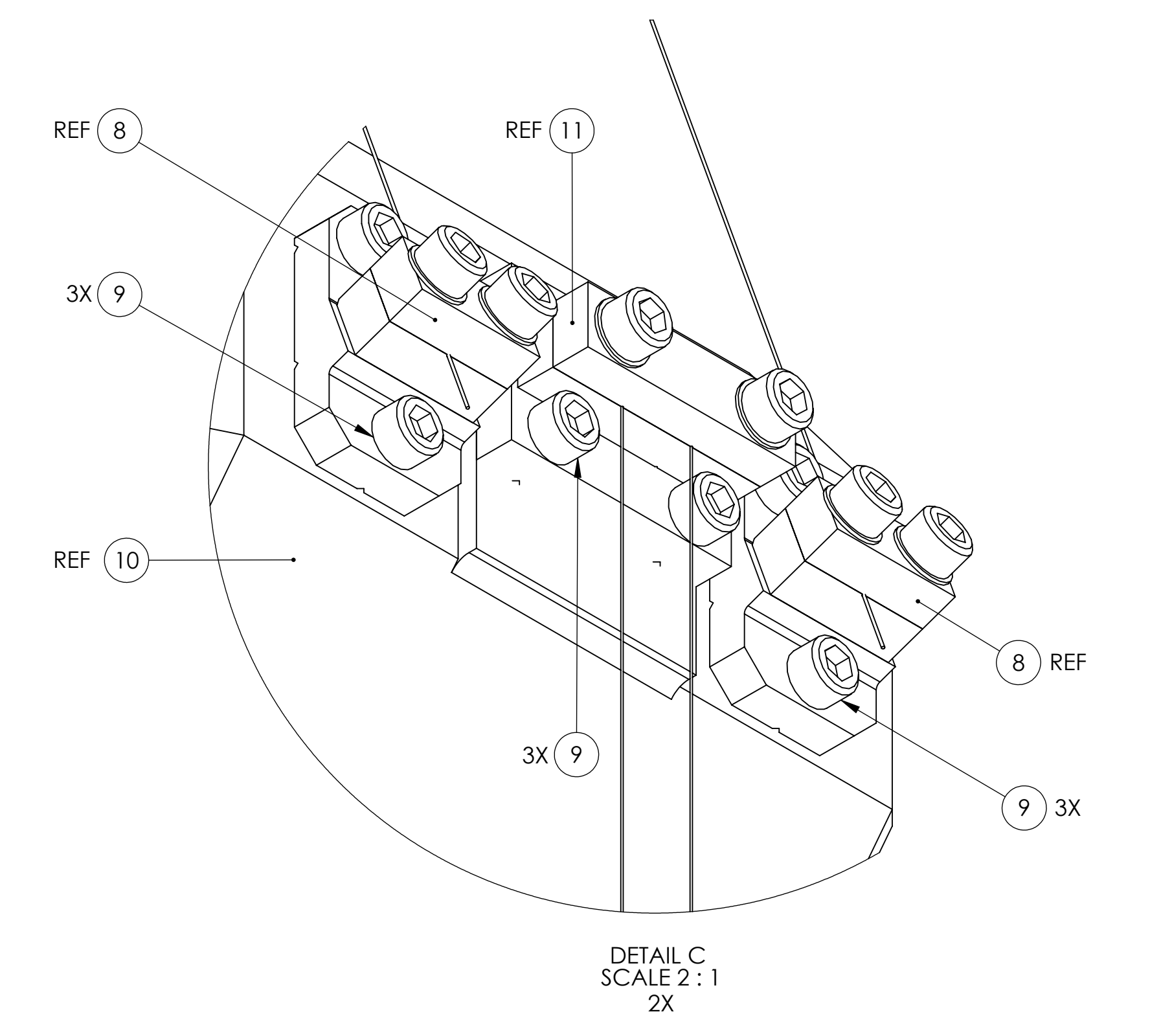
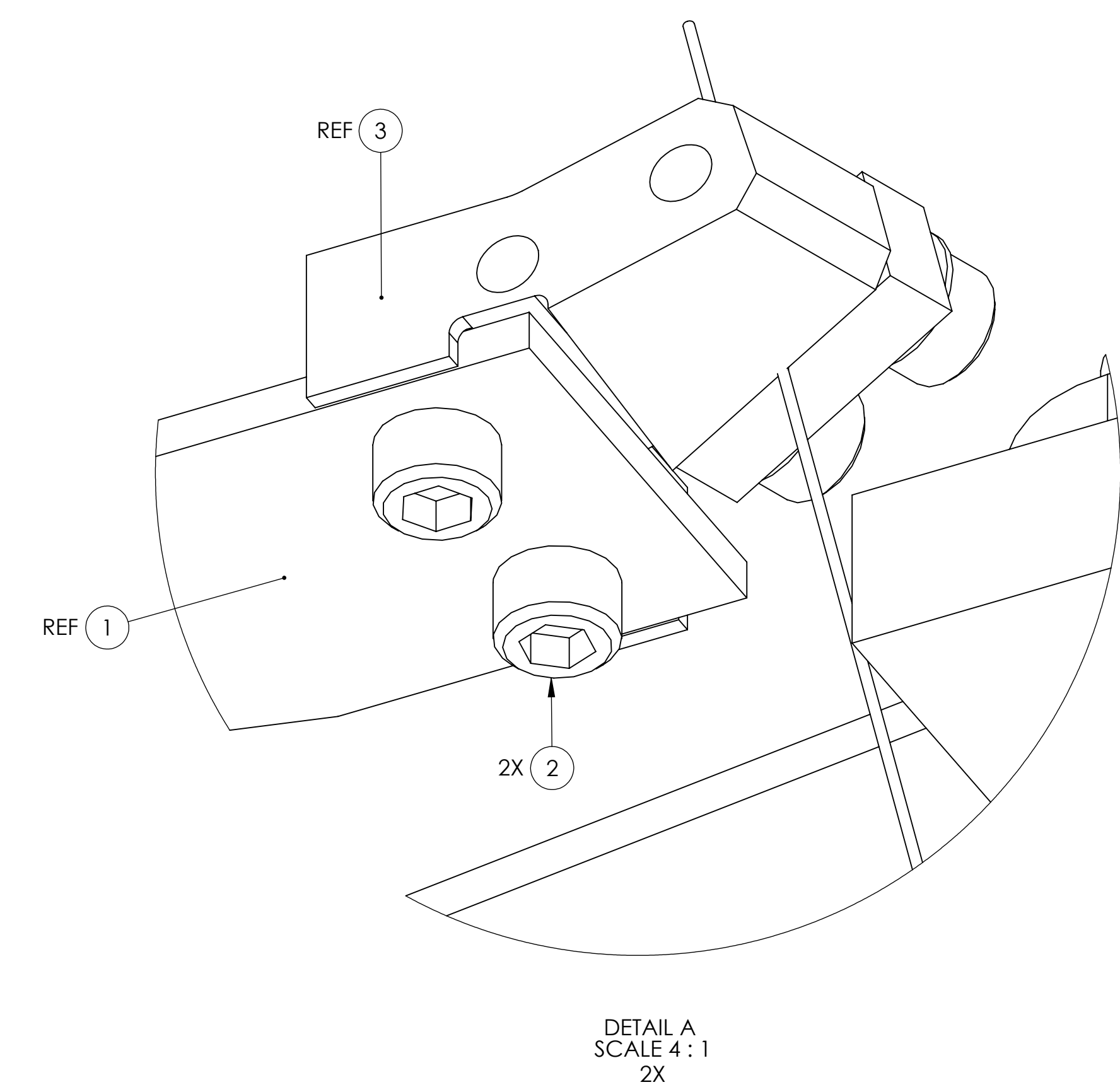
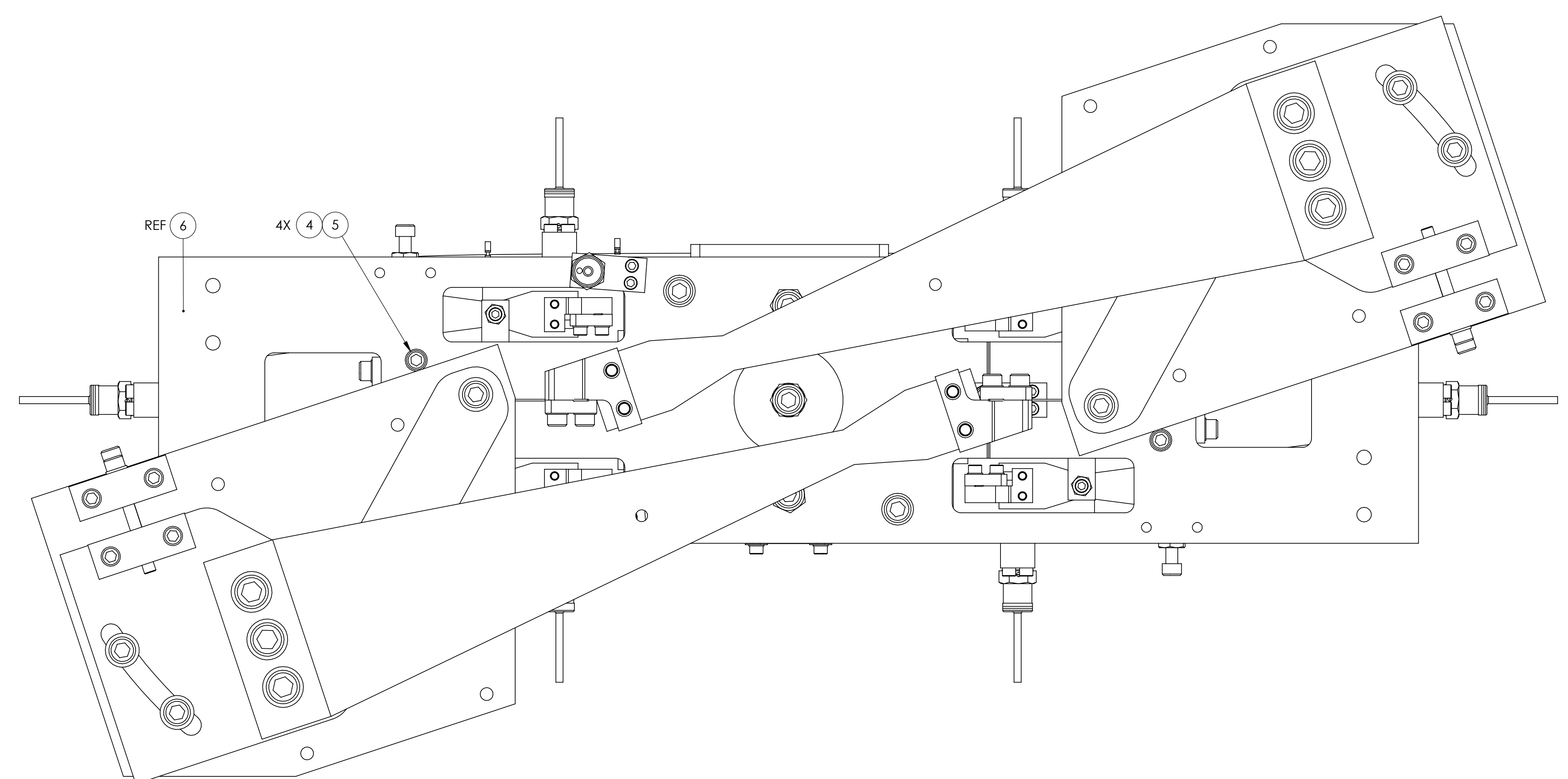
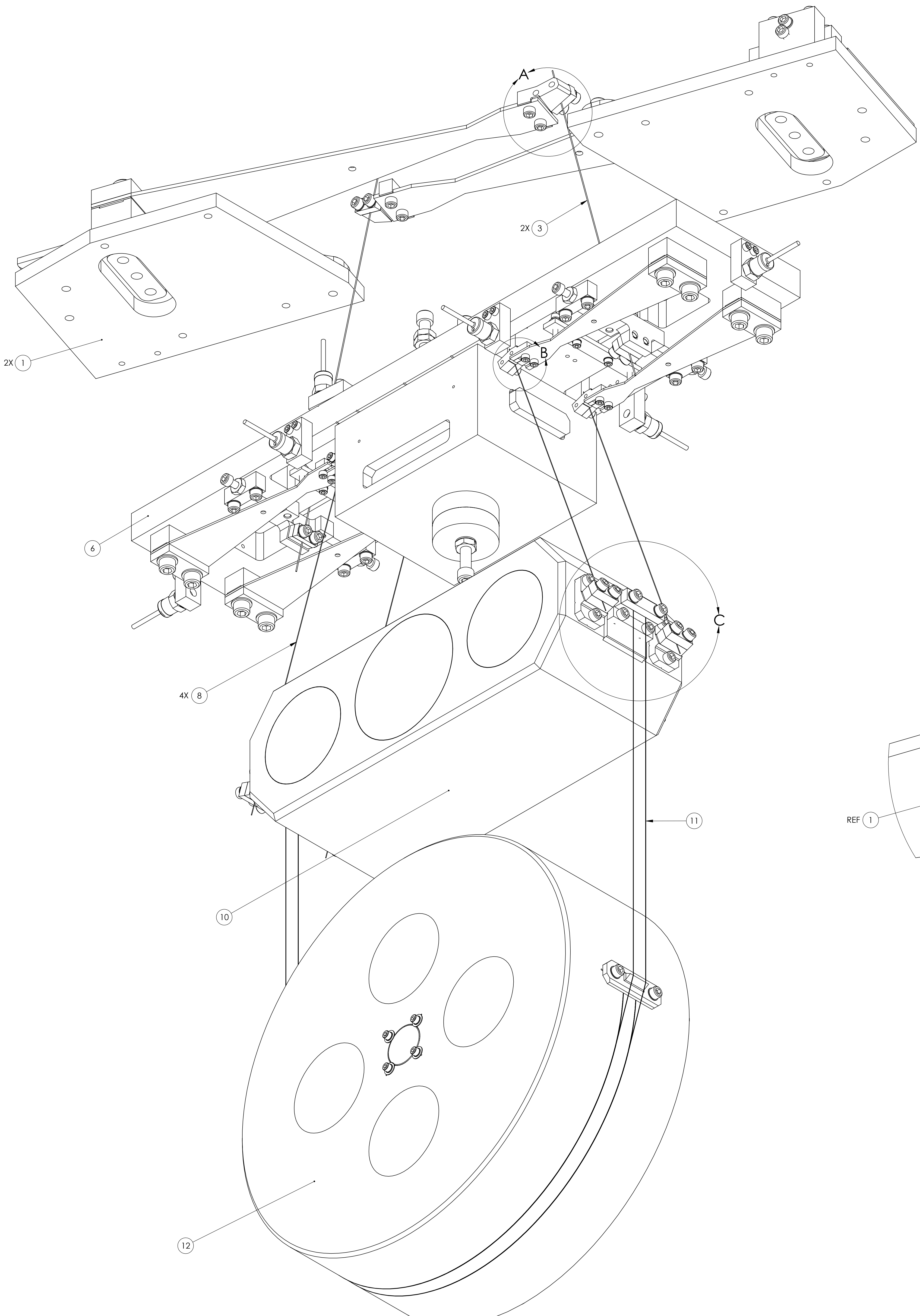

ITEM NO.	PART NUMBER	DESCRIPTION	MATERIAL	REQ	SPARE	TOTAL
12	D070337	TEST MASS ASSY	N/A	1	0	1
11	D070436	LOWER LOOP WIRE ASSY	N/A	1	0	1
10	D070334	INTERMEDIATE MASS ASSY	N/A	1	0	1
9	-	SCREW, SOCKET HEAD CAP, #8-32 UNC-2A X 0.625 LONG	Ag-PLATED 300 SSSL	18	4	22
8	D070393	INTERMEDIATE WIRE ASSY	N/A	4	0	4
7	-	SCREW, SOCKET HEAD CAP, #4-40 UNC-2A X 0.25 LONG	Ag-PLATED 300 SSSL	8	2	10
6	D070335	UPPER MASS ASSY	N/A	1	0	1
5	-	SCREW, SOCKET HEAD CAP, #8-32 UNC-2A X 1.125 LONG	300 SSSL	4	1	5
4	-	WASHER, FLAT, #8 (NAS 620-CBL OR EQUIVALENT)	300 SSSL	4	1	5
3	D070340	UPPER WIRE ASSY	N/A	2	0	2
2	-	SCREW, SOCKET HEAD CAP, #8-32 UNC-2A X 0.5 LONG	Ag-PLATED 300 SSSL	4	1	5
1	D070326	ROTATIONAL ADJUSTER	N/A	2	0	2
PARTS LIST						

NOTES AND TOLERANCES, (UNLESS OTHERWISE SPECIFIED) 1. PARTS TO BE ASSEMBLED ACCORDING TO E080208 HLTS ASSEMBLY SPECIFICATION.		CALIFORNIA INSTITUTE OF TECHNOLOGY MASSACHUSETTS INSTITUTE OF TECHNOLOGY		PART NAME HLTS SUSPENSION ASSY	
MATERIAL	N/A	FINISH	N/A μinch	SYSTEM ADVANCED LIGO	SUB-SYSTEM SUS
NEXT ASSY HLTS OVERALL ASSY				DESIGNER D. BRIDGES	DATE 24 JUL 2009
				DRAFTER D. BRIDGES	DATE 27 JUL 2009
				CHECKER J. ROWIE	DATE 28 JUL 2009
				APPROVAL	SCALE: 1:1
				DWG. NO. D070332	REV. v1
				SHEET 1 OF 1	