

NOTES CONTINUED:

- 5. SCRIBE, ENGRAVE, OR MECHANICALLY STAMP (NO DYES OR INKS) A UNIQUE THREE DIGIT SERIAL NUMBER & REVISION NUMBER ON EACH PART. SERIAL NUMBERS & REVISION NUMBER START AT 001 FOR THE FIRST ARTICLE AND PROCEED CONSECUTIVELY. BAG AND TAG PARTS WITH THEIR DRAWING PART NUMBER, REVISION, VARIANT OR "TYPE" (IF APPLICABLE), AND QUANTITY. IF PARTS ARE TOO SMALL TO SCRIBE, BAGGING AND TAGGING ALONE IS SUFFICIENT.  
EXAMPLE (PART): 001-v1  
EXAMPLE (TAG): DXXXXXX-VY, TYPE-XX, QTY: TBD
- 6. MACHINE ALL SURFACES TO REMOVE OXIDES AND MILL FINISH. USE OF ABRASIVE REMOVAL TECHNIQUES IS NOT ALLOWED.
- 7. ALL PARTS SHALL BE MANUFACTURED IN ACCORDANCE WITH LIGO SPECIFICATION E0900364.
- 8. DO NOT REMOVE SHARP EDGES WHERE INDICATED.

REV.	DATE	DCN #	DRAWING TREE #
v1	26 MAY 2009	E0900160	E080191
v2	28 JUN 2010	E1000236	E080191
v3	01 JAN 2011	E1100001	E080191

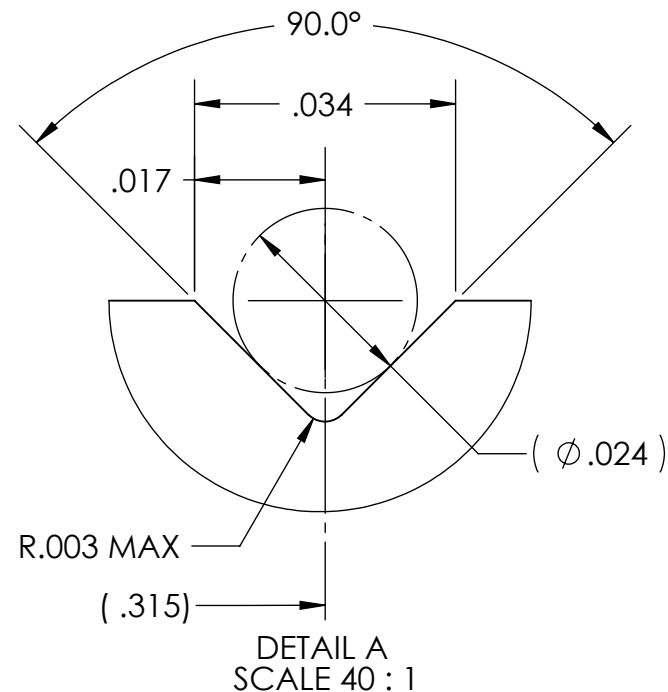
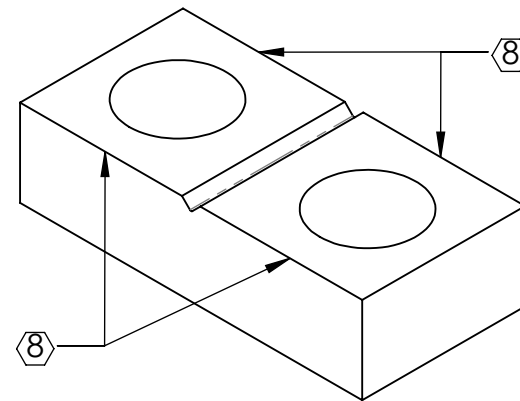
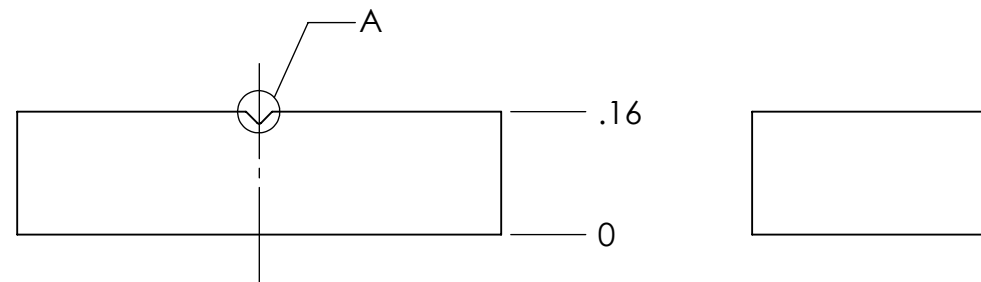
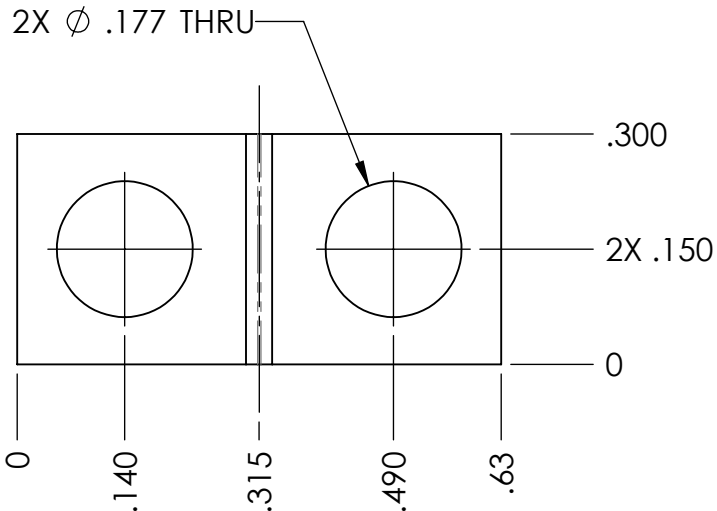

NOTES AND TOLERANCES: (UNLESS OTHERWISE SPECIFIED)

DIMENSIONS ARE IN INCHES  
 TOLERANCES:  
 .XX ± .01  
 .XXX ± .005  
 ANGULAR ± 0.5°

1. INTERPRET DRAWING PER ASME Y14.5-1994.  
 2. REMOVE ALL SHARP EDGES, R.02 MIN.  
 3. DO NOT SCALE FROM DRAWING.  
 4. ALL MACHINING FLUIDS MUST BE FULLY SYNTHETIC, FULLY WATER SOLUBLE AND FREE OF SULFUR, SILICONE, AND CHLORINE.

**MATERIAL**  
304, 316 OR 302 SSSL

**FINISH**  
63 μinch

**LIGO** CALIFORNIA INSTITUTE OF TECHNOLOGY  
 MASSACHUSETTS INSTITUTE OF TECHNOLOGY

SYSTEM: **ADVANCED LIGO**      SUB-SYSTEM: **SUS**

NEXT ASSY: **UPPER WIRE ASSEMBLY**

**PART NAME**  
LOWER CLAMP, UPPER WIRE, OUTSIDE

DESIGNER	B. KIRSNER	05 MAR 2008	SIZE	DWG. NO.	REV.
DRAFTER	D. BRIDGES	05 JAN 2011	A	<b>D020624</b>	v3
CHECKER	J. ROMIE	05 JAN 2011	SCALE: 4:1	PROJECTION:	SHEET 1 OF 1
APPROVAL					