

REV.	DATE	DCN #	DRAWING TREE #
A	01 AUG 2008	E080418-00	E080191-01-D

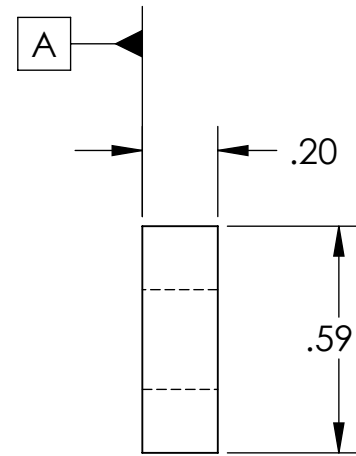
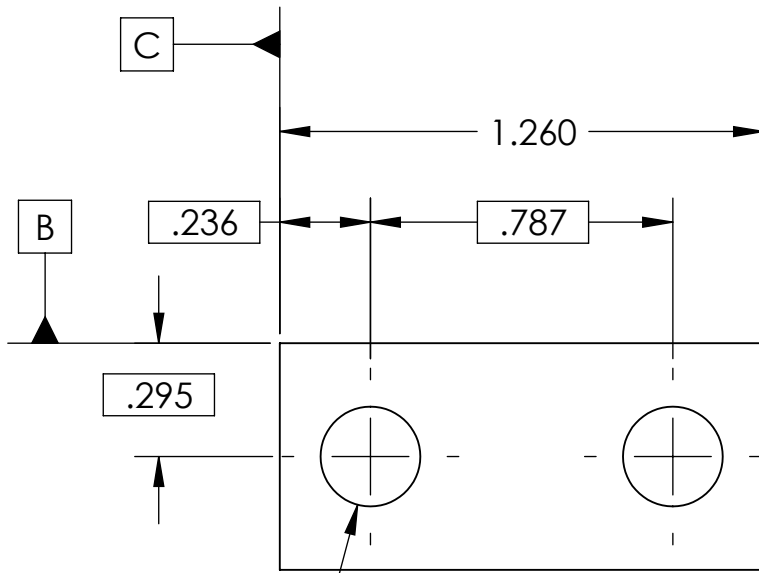
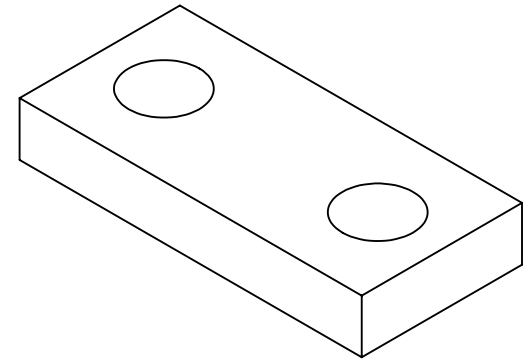

2X ϕ .260 THRU

ϕ	ϕ	.010	A	B	C
--------	--------	------	---	---	---

NOTES: (UNLESS OTHERWISE SPECIFIED)

- DO NOT SCALE FROM DRAWING.
- REMOVE ALL SHARP EDGES, R.02 MAX.
- ALL MACHINING FLUIDS SHALL BE WATER SOLUBLE AND FREE OF SULFUR, CHLORINE AND SILICONE.
- BAG ALL ITEMS INDIVIDUALLY AND TAG EACH BAG WITH DRAWING NUMBER, REVISION AND QUANTITY REQUIRED.
EXAMPLE: D020623-00 QTY: tbd
- L AND LN VARIANTS OF 304, 316 AND 302 TYPE STAINLESS STEEL ARE ALSO ACCEPTABLE.
- 303 TYPE STAINLESS STEEL IS NOT ACCEPTABLE.

DIMENSIONS ARE IN INCHES

TOLERANCES:
 .XX \pm 0.01
 .XXX \pm 0.005

ANGULAR \pm 0.5 °

MATERIAL
304, 316 OR 302 SSSL

FINISH
32 μ inch

	NAME	DATE
DRAWN	B. KIRSNER	2 MAY 2008
CHECKED	M. MEYER	08 MAY 2008
APPROVED		



SYSTEM **ADVANCED LIGO**

SUB-SYSTEM **SUS**

NEXT ASSY **UPPER MASS ASSEMBLY**

PART NAME
BLADE CLAMP, LOWER BLADE, OUTSIDE

SCALE: 1:1 PROJECTION: SHEET 1 OF 1

SIZE DWG. NO. **D020623** REV. **A**