

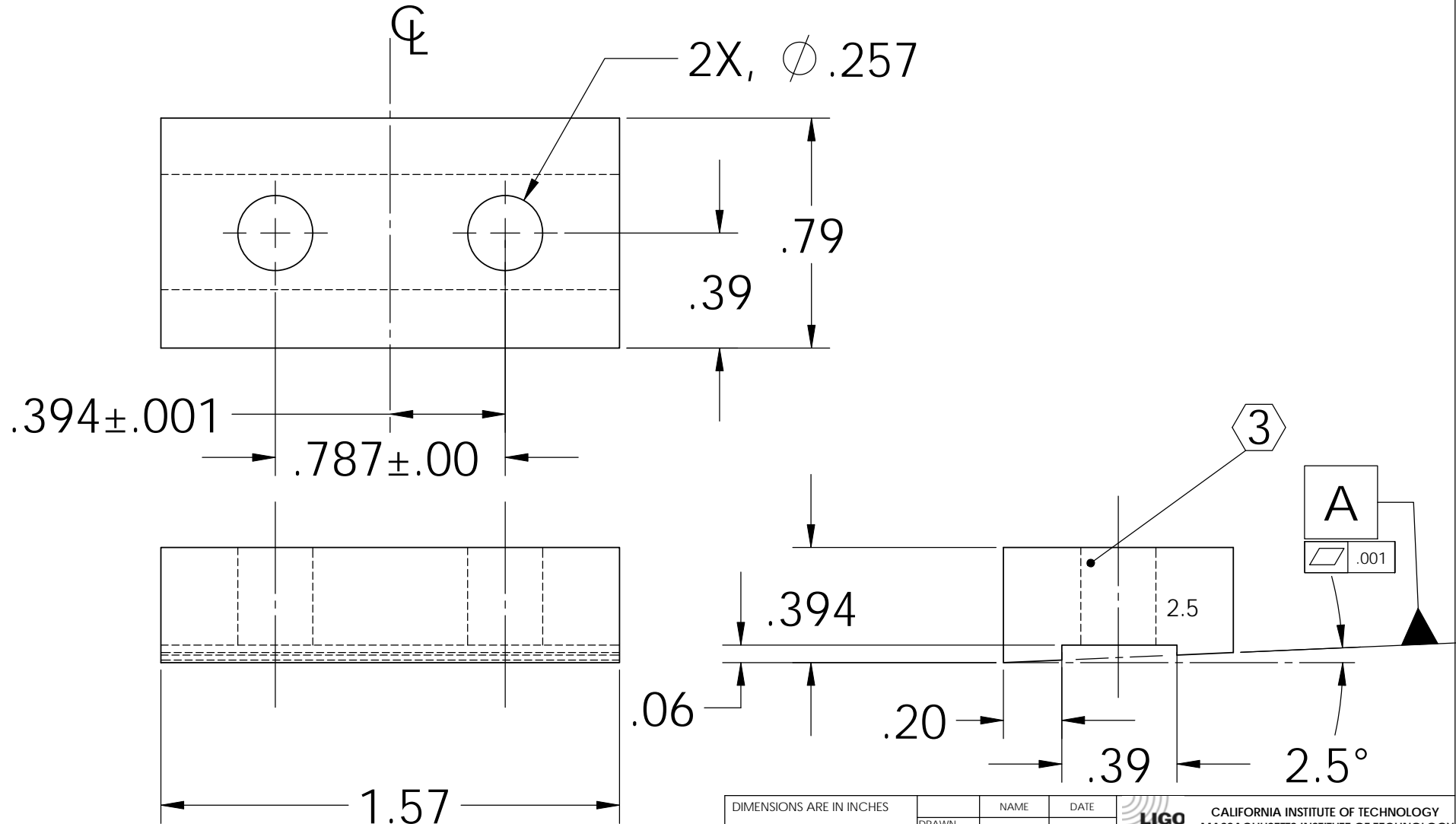

NOTES: (UNLESS OTHERWISE SPECIFIED)

1. DIMENSIONS IN INCHES
2. ALL MACHINING FLUIDS SHALL BE WATER SOLUBLE AND FREE OF SULFUR, CHLORINE AND SILICONE, SUCH AS CINCINNATI MILACRON'S CIMTECH 410 (STAINLESS STEEL)
- ③ USING A VIBRATORY TOOL MARK PART AS INDICATED

| REV. | DATE | DCN # | DRAWING TREE # |
|------|---------------|-------------|----------------|
| A | 24 JUNE 2004 | E040303-00 | |
| v1 | 21 APRIL 2009 | E0900107-v1 | |



| | | | | |
|--|----------------------|------------|----------|---|
| DIMENSIONS ARE IN INCHES | | NAME | DATE |  CALIFORNIA INSTITUTE OF TECHNOLOGY MASSACHUSETTS INSTITUTE OF TECHNOLOGY |
| TOLERANCES: .XX ±0.01 .XXX ±0.005 ANGULAR ±.25° | | CIT/RJ | 05/02 | |
| MATERIAL | 302, 304 OR 316 SSTL | CHECKED | | SYSTEM ADVANCED LIGO |
| FINISH | | | | SUB-SYSTEM SUS |
| | | COMMENTS: | | NEXT ASSY LIBRARY OF CLAMPS |
| | | | | PART NAME UPPER BLADE CLAMP UPPERSIDE ANGLED (2.5°) |
| | | SIZE | DWG. NO. | REV. |
| | | A | D020328 | v1 |
| | | SCALE: NTS | | SHEET 1 OF 1 |