

NOTES CONTINUED:

- ⑤ SCRIBE, ENGRAVE, OR MECHANICALLY STAMP (NO INKS OR DYES) DRAWING PART NUMBER AND REVISION ON NOTED SURFACE FOLLOWED ON THE NEXT LINE BY A THREE DIGIT SERIAL NUMBER. SERIAL NUMBERS START AT 001 FOR THE FIRST ARTICLE AND PROCEED CONSECUTIVELY. USE .07" HIGH CHARACTERS. EXAMPLE: DXXXXXX-VY, S/N 001. A VIBRATORY TOOL MAY BE USED.
- ⑥ SCRIBE, ENGRAVE, OR MECHANICALLY STAMP (NO INKS OR DYES) MARKING AS SHOWN. A VIBRATORY TOOL MAY BE USED.

REV.	DATE	DCN #	DRAWING TREE #
v1	19 MAY 2009	E0900154	E080191
-	-	-	-
-	-	-	-

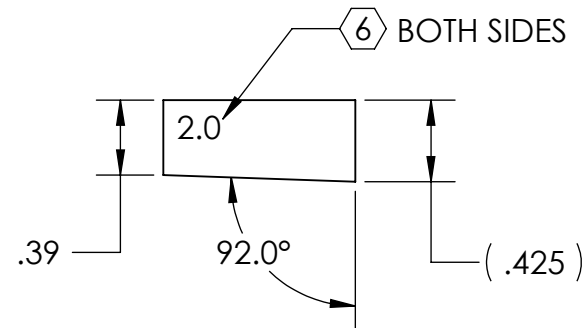
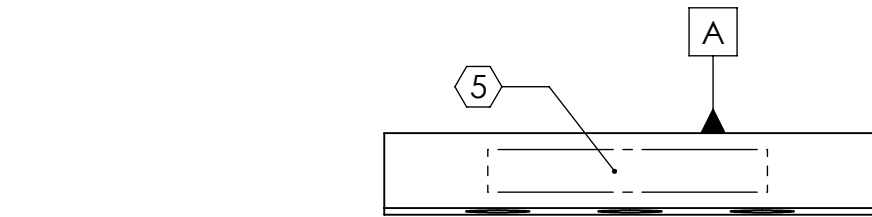
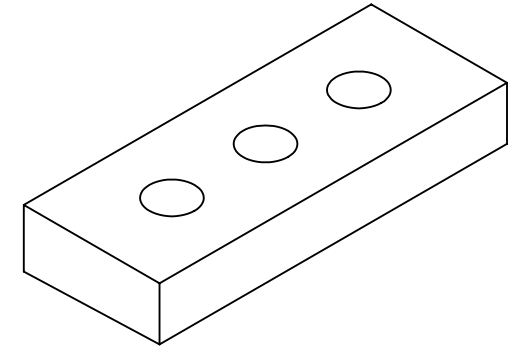
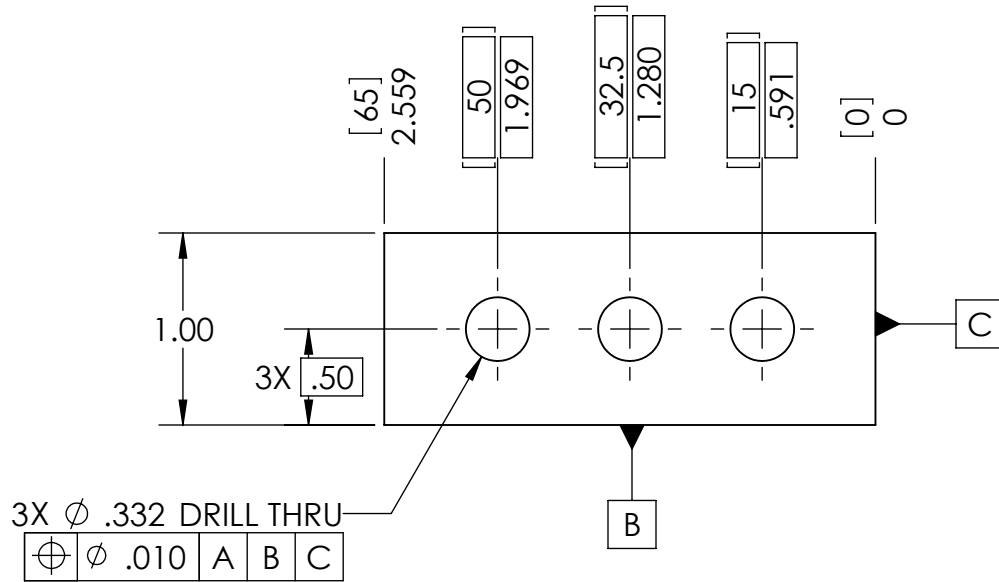

3X ϕ .332 DRILL THRU

ϕ	ϕ .010	A	B	C
--------	-------------	---	---	---

NOTES AND TOLERANCES: (UNLESS OTHERWISE SPECIFIED)

DIMENSIONS ARE IN INCHES [MM]	1. INTERPRET DRAWING PER ASME Y14.5-1994.
TOLERANCES:	2. REMOVE ALL SHARP EDGES, R.02 MIN.
.XX ± .01	3. DO NOT SCALE FROM DRAWING.
.XXX ± .005	4. ALL MACHINING FLUIDS SHALL BE WATER SOLUBLE AND FREE OF SULFUR, CHLORINE AND SILICONE, SUCH AS CINCINNATI MILACRON'S CIMTECH 410.
ANGULAR ± 0.1°	MATERIAL
	304, 316 OR 302 SSSL
	FINISH
	32 μ inch

LIGO CALIFORNIA INSTITUTE OF TECHNOLOGY
 MASSACHUSETTS INSTITUTE OF TECHNOLOGY

SYSTEM: **ADVANCED LIGO** SUB-SYSTEM: **SUS**

NEXT ASSY: **LIBRARY OF CLAMPS, UPPER BLADE**

PART NAME		BLADE CLAMP (2.0 DEGREE), UPPER BLADE, OUTSIDE	
DESIGNER	D. BRIDGES	21 APR 2009	SIZE DWG. NO.
DRAFTER	D. BRIDGES	22 APR 2009	A
CHECKER	M. MEYER	22 APR 2009	D0900677
APPROVAL			REV. v1
SCALE: 1:1		PROJECTION:	SHEET 1 OF 1