

NOTES CONTINUED:

5 SCRIBE, ENGRAVE, OR MECHANICALLY STAMP (NO INKS OR DYES) DRAWING PART NUMBER AND REVISION ON NOTED SURFACE FOLLOWED ON THE NEXT LINE BY A THREE DIGIT SERIAL NUMBER. SERIAL NUMBERS START AT 001 FOR THE FIRST ARTICLE AND PROCEED CONSECUTIVELY. USE .07" HIGH CHARACTERS. EXAMPLE: DXXXXXX-VY, S/N 001. A VIBRATORY TOOL MAY BE USED.

REV.	DATE	DCN #	DRAWING TREE #
v1	26 MAY 2009	E0900160	E080191

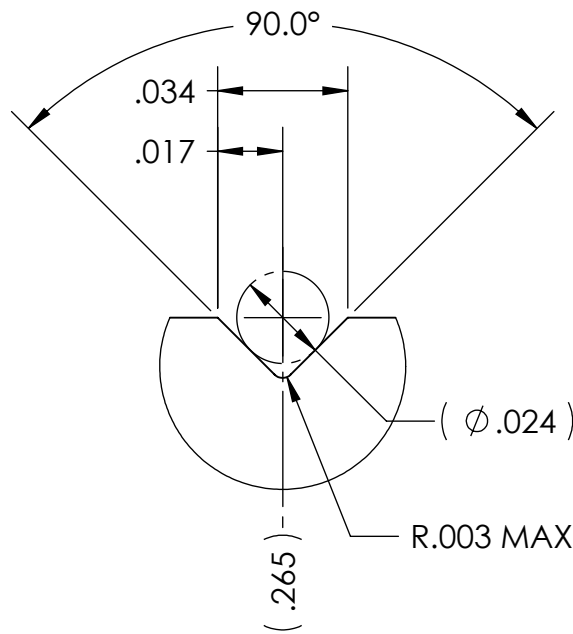
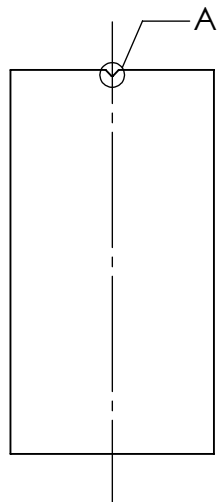
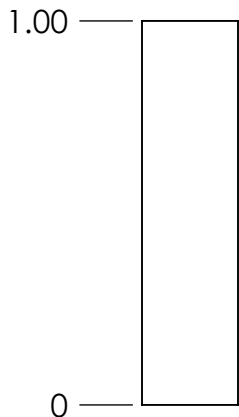
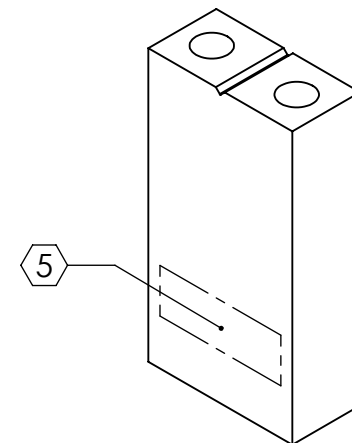
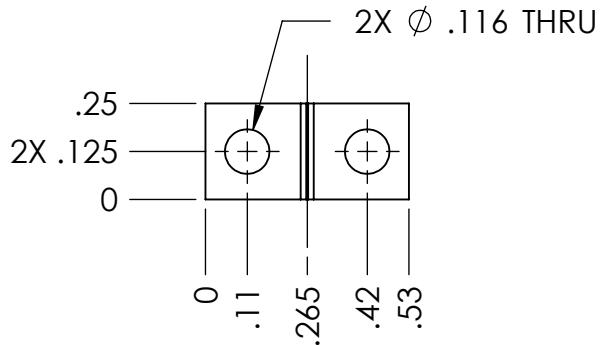

DETAIL A
SCALE 20 : 1

NOTES AND TOLERANCES: (UNLESS OTHERWISE SPECIFIED)

DIMENSIONS ARE IN INCHES

TOLERANCES:
.XX ± .03
.XXX ± .005

ANGULAR ± 0.5°

1. INTERPRET DRAWING PER ASME Y14.5-1994.
2. REMOVE ALL SHARP EDGES, R.02 MIN.
3. DO NOT SCALE FROM DRAWING.
4. ALL MACHINING FLUIDS SHALL BE WATER SOLUBLE AND FREE OF SULFUR, CHLORINE AND SILICONE, SUCH AS CINCINNATI MILACRON'S CIMTECH 410.

MATERIAL	304, 316 OR 302 SSSL	FINISH	63 μinch
----------	----------------------	--------	----------

LIGO CALIFORNIA INSTITUTE OF TECHNOLOGY
MASSACHUSETTS INSTITUTE OF TECHNOLOGY

SYSTEM: **ADVANCED LIGO** SUB-SYSTEM: **SUS**

NEXT ASSY: **UPPER WIRE JIG, HLTS**

PART NAME		WIRE START CLAMP, INSIDE		
DESIGNER	M. MEYER	02 APR 2009	SIZE	DWG. NO.
DRAFTER	D. BRIDGES	05 JUN 2009	A	D0900603
CHECKER	M. MEYER	05 JUN 2009	SCALE: 2:1	PROJECTION:
APPROVAL				SHEET 1 OF 1