

REV.	DATE	DCN #	DRAWING TREE #
A	24 JUNE 2004	E040303-00	
B	09 APRIL 2008	E080156-00	
v1	21 APRIL 2009	E0900107-v1	

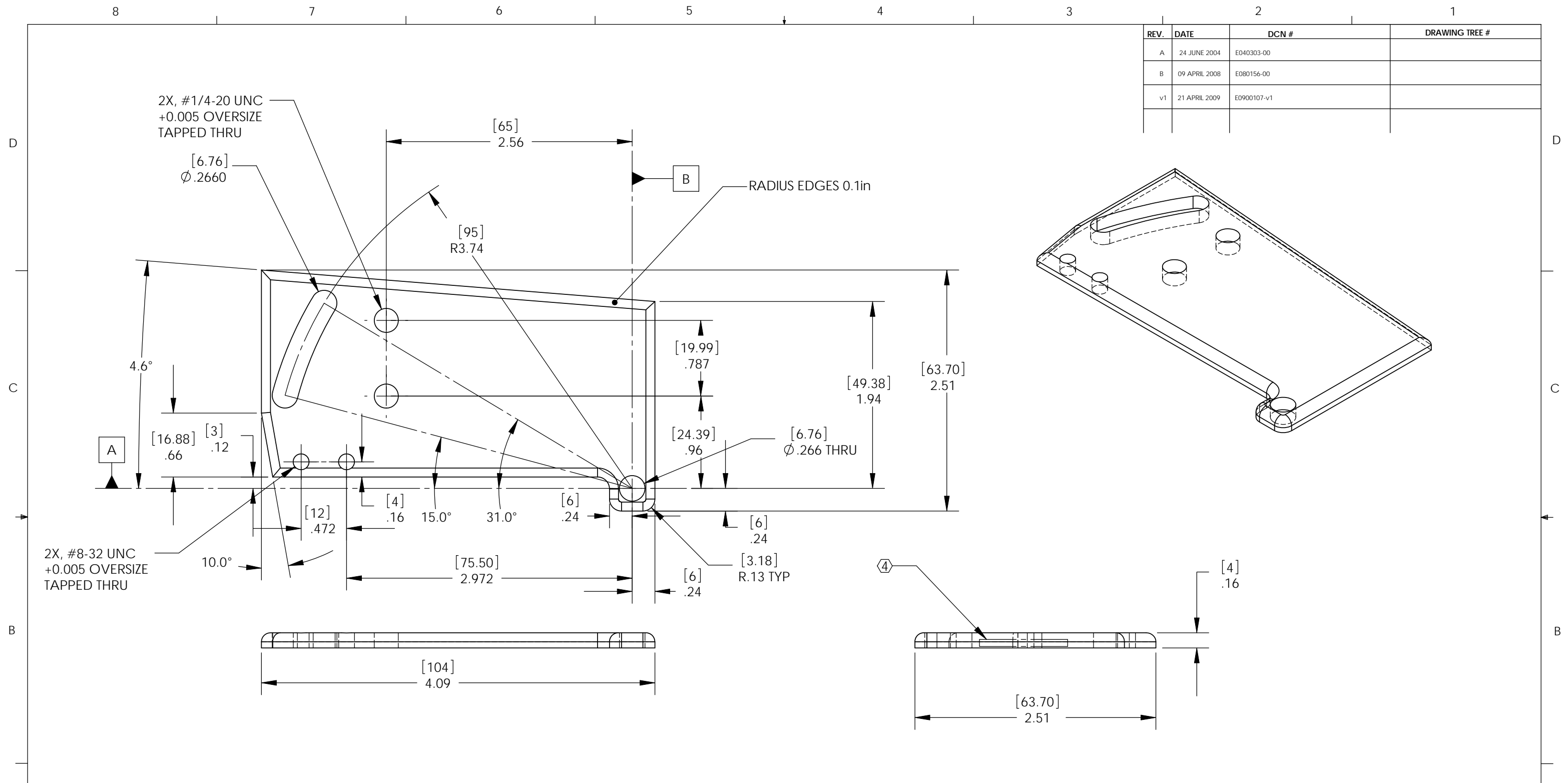

PARTS LIST																							
NOTES: (UNLESS OTHERWISE SPECIFIED)																							
1. REMOVE ALL SHARP EDGES, R.02 MIN. 2. DO NOT SCALE FROM DRAWING. 3. ALL MACHINING FLUIDS SHALL BE WATER SOLUBLE AND FREE OF SULFUR, CHLORINE AND SILICONE, SUCH AS CINCINNATI MILACRON'S CIMTECH 410 (STAINLESS STEEL)		DIMENSIONS ARE IN INCHES [mm] TOLERANCES: .XX ± 0.01 .XXX ± 0.005 ANGULAR ± 0.5 °																					
④ SCRIBE, ENGRAVE OR STAMP DRAWING PARTNUMBER ON NOTED SURFACE OF PART AND A THREE DIGIT SERIAL NUMBER. SERIAL NUMBERS START AT 001 FOR THE FIRST PART AND PROCEED CONSECUTIVELY. USE .07" HIGH CHARACTERS. EXAMPLE: D020188- 001. A VIBRATORY TOOL MAY BE USED.		MATERIAL 302, 304 OR 316 SSSL FINISH N/A																					
<table border="1"> <thead> <tr> <th></th> <th>NAME</th> <th>DATE</th> </tr> </thead> <tbody> <tr> <td>DRAWN</td> <td>MPL (IGR)</td> <td>3 SEP 2003</td> </tr> <tr> <td>CHECKED</td> <td>JHR, CIT</td> <td>16 SEP 2003</td> </tr> <tr> <td>APPROVED</td> <td></td> <td></td> </tr> </tbody> </table>			NAME	DATE	DRAWN	MPL (IGR)	3 SEP 2003	CHECKED	JHR, CIT	16 SEP 2003	APPROVED			<table border="1"> <tr> <td>SYSTEM</td> <td>ADVANCED LIGO</td> </tr> <tr> <td>SUB-SYSTEM</td> <td>SUS</td> </tr> <tr> <td>NEXT ASSY</td> <td>ROTATIONAL ADJUSTER</td> </tr> <tr> <td>PART NAME</td> <td>ROTATING PLATE</td> </tr> </table>		SYSTEM	ADVANCED LIGO	SUB-SYSTEM	SUS	NEXT ASSY	ROTATIONAL ADJUSTER	PART NAME	ROTATING PLATE
	NAME	DATE																					
DRAWN	MPL (IGR)	3 SEP 2003																					
CHECKED	JHR, CIT	16 SEP 2003																					
APPROVED																							
SYSTEM	ADVANCED LIGO																						
SUB-SYSTEM	SUS																						
NEXT ASSY	ROTATIONAL ADJUSTER																						
PART NAME	ROTATING PLATE																						
<table border="1"> <tr> <td>SIZE</td> <td>DWG. NO.</td> <td>REV.</td> </tr> <tr> <td>B</td> <td>D030447</td> <td>v1</td> </tr> </table>		SIZE	DWG. NO.	REV.	B	D030447	v1	SCALE: 1:1 PROJECTION: SHEET 1 OF 1															
SIZE	DWG. NO.	REV.																					
B	D030447	v1																					

CALIFORNIA INSTITUTE OF TECHNOLOGY
 MASSACHUSETTS INSTITUTE OF TECHNOLOGY
 IGR, GLASGOW UNIVERSITY GEO 600 GROUP