

REV.	DATE	DCN #	DRAWING TREE #
v2	11 Mar. 2011	E1100015	E1100016

NOTES CONTINUED:

- ALL MACHINING FLUIDS MUST BE FULLY SYNTHETIC, FULLY WATER SOLUBLE AND FREE OF SULFUR, SILICONE AND CHLORINE.
- SCRIBE, ENGRAVE, OR MECHANICALLY STAMP (NO INKS OR DYES) DRAWING PART NUMBER, REVISION (AND VARIANT OR "TYPE" IF APPLICABLE ON NOTED SURFACE OF PART FOLLOWED ON THE NEXT LINE WITH A THREE DIGIT SERIAL NUMBER. SERIAL NUMBERS START AT 001 FOR THE FIRST ARTICLE AND PROCEED CONSECUTIVELY. USE MINIMUM 0.12 HIGH CHARACTERS, UNLESS THE SIZE OF THE PART DICTATES SMALLER CHARACTERS. A VIBRATORY TOOL MAY BE USED. EXAMPLE DXXXXXXX-VY, TYPE-XX, S/N XXX.
- APPROXIMATE WEIGHT = 6.46 LB.
- ALL PARTS SHALL BE MANUFACTURED IN ACCORDANCE WITH LIGO SPECIFICATION E0900364.
- PAIN: ALL VISIBLE SURFACES (exclude fastening hardware) EXCEPT AREAS IDENTIFIED BY $\triangle M$ MEDIUM BLUE SHERWIN WILLIAMS (POLANE (R) T-PLUS POLYURETHANE ENAMEL) #SW-F63TX-L-2822-5864 PRIME WITH SHERWIN WILLIAMS INDUSTRIAL WASH PRIMER P60G2 "OXI SOLV RUST INHIBITOR" TO BE APPLIED PER MFG. INSTRUCTIONS TO ALL UNPAINTED SURFACES. BOTH TAPPED AND THRU HOLES WILL BE PLUGGED DURING APPLICATION.

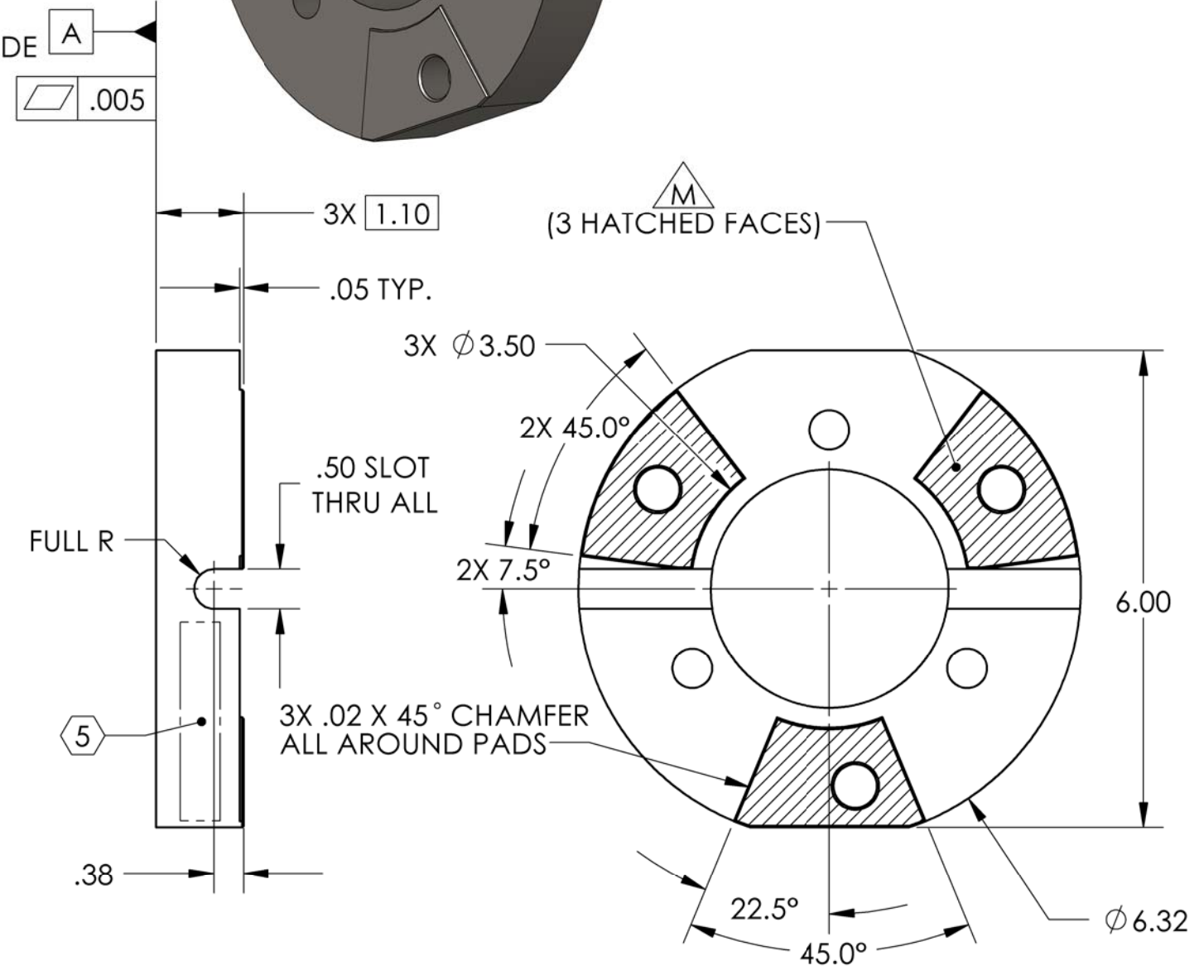
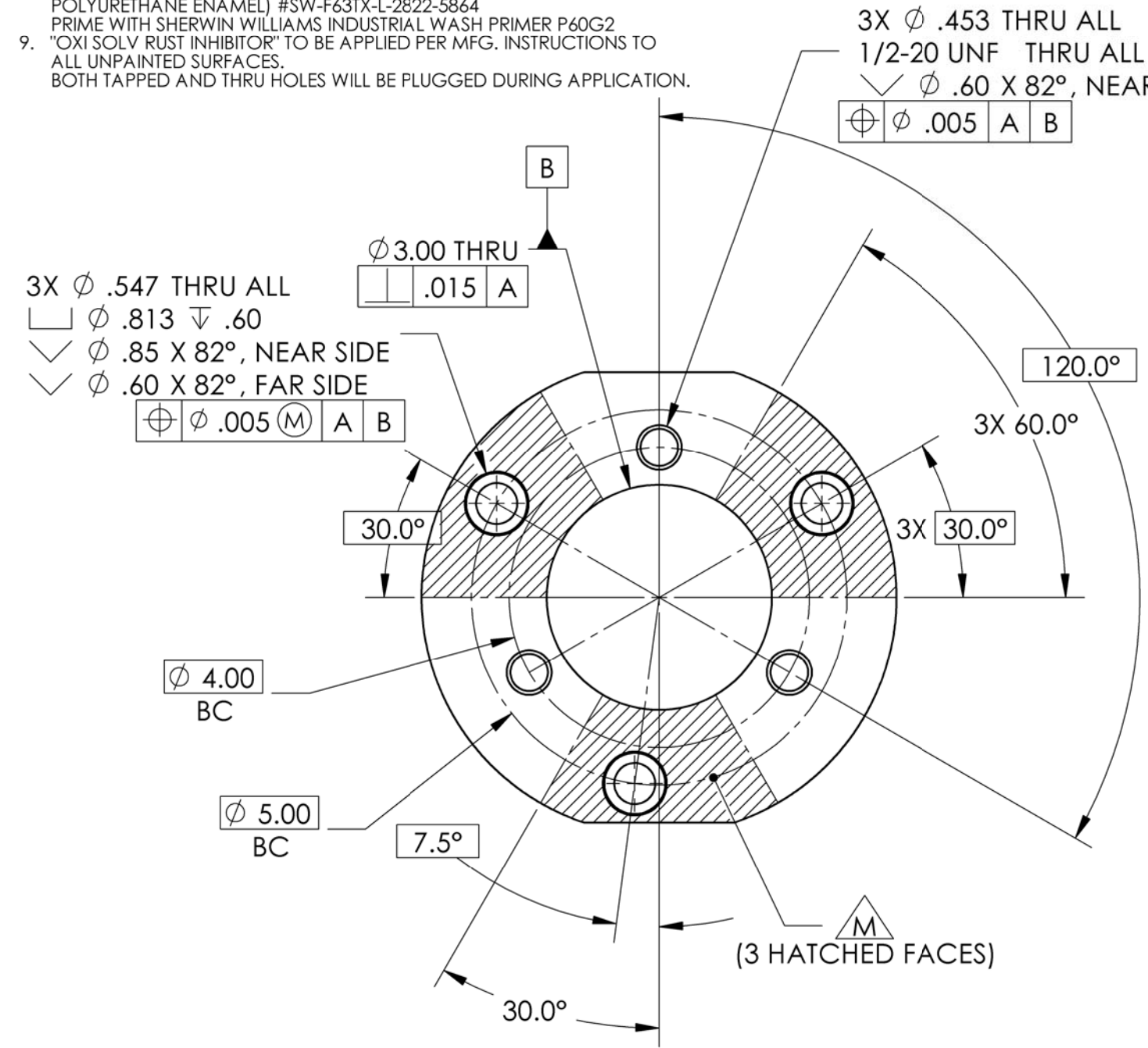
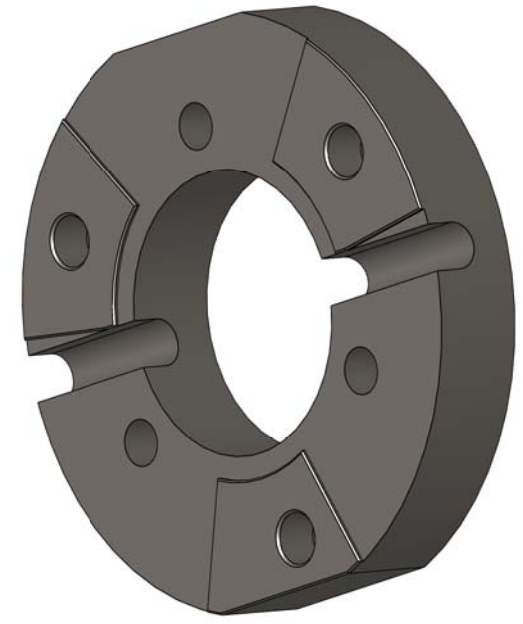

D080547 HAM HEPI Horz Actuator Adapter 1, PART PDM REV: X-003, DRAWING PDM REV: X-001

NOTES AND TOLERANCES: (UNLESS OTHERWISE SPECIFIED)				LIGO CALIFORNIA INSTITUTE OF TECHNOLOGY MASSACHUSETTS INSTITUTE OF TECHNOLOGY		PART NAME						
DIMENSIONS ARE IN INCHES TOLERANCES: .XX ± .015 .XXX ± .005 ANGULAR ± .5°				1. INTERPRET DRAWING PER ASME Y14.5-1994. 2. REMOVE ALL SHARP EDGES, R.02 MIN. 3. DO NOT SCALE FROM DRAWING. 4. ALL MACHINING FLUIDS MUST BE FULLY SYNTHETIC, FULLY WATER SOLUBLE AND FREE OF SULFUR, SILICONE, AND CHLORINE.		HAM HEPI Horz Actuator Adapter 1						
MATERIAL AISI 1020 Steel, Cold Rolled		FINISH 63 μinch		SYSTEM ADVANCED LIGO		SUB-SYSTEM SEI		DESIGNER A. STEIN	DATE 27 Jan. 2009	SIZE B	DWG. NO. D080547	REV. v2
NEXT ASSY D1100145, D1100147				CHECKER A. STEIN		APPROVAL K. MASON		DATE 06/16/2008	DATE 11 Mar. 2011	SCALE 1:2	PROJECTION	SHEET 1 OF 1